

CATA LOGO



INDEX

l'espressione del **design** **20**

GRANDANGOLO	22
FUSION	42
AREA	66
HAPPY HOUR / LAVABI D'APPOGGIO	98
DAYTIME / DAYTIME EVO	126
NIDO	150
ERIKA <small>pro</small> / ERIKA <small>pro</small> Q	166
SLIDING <small>wood system</small>	190
LIF.ST <small>showertrays</small>	210

i grandi **classici** **224**

YOU & ME	226
SCULTURE EVENTO / SCULTURE	248
DOLCEVITA	278

pro come **progetto** **294**

LAVABI SOSPESI O DA MOBILE	300
LAVABI SOSPESI CON COLONNA O SEMICOLONNA	304
LAVABI INCASSO / SEMINCASSO	308
LAVAMANI E SPECIALI	312
VASI E BIDET SOSPESI	316
VASI E BIDET A TERRA / VASI CON CASSETTA	320
CASSETTA MONOLITH	324
ORINATOI / TURCHE / SPECIALI	326
PIATTI DOCCIA	328
AUTONOMY	332

le pagine **tecniche** **334**

SIMBOLOGIA

KEY SYMBOLBESCHREIBUNG SYMBOLES SIMBOLOGÍA СИСТЕМА УСЛОВНЫХ ОБОЗНАЧЕНИЙ



solo monoforo
only one hole faucet
nur Einloch
seulement à un trou
sólo orificio único
только с одним отверстием



monoforo a destra
one hole on the right
loch auf der rechten
trou droite
orificio a la derecha
отверстие справа



monoforo a sinistra
one hole on the left
öffnung an der linken
trou à gauche
orificio a la izquierda
отверстие на левой



monoforo predisposizione triforo
one hole (predisposed for three hole faucet)
Einloch mit Vorrichtung für Dreiloch
à un trou avec possibilité de trois trous
orificio único previsto triple orificio
только с одним отверстием, предусмотрена установка с тремя отверстиями



monoforo in 2 posizioni
one hole in 2 positions
Einloch in 2 Positionen
à un trou en 2 positions
orificio único en 2 posiciones
двупозиционная установка с одним отверстием



triforo
three faucet holes
Dreiloch
à trois trous
triple orificio
с тремя отверстиями



senza fori
without faucet holes
ohne Löcher
sans trous
sin orificios
без отверстий



senza fori, predisposizione monoforo in 1 posizione
without faucet holes, predisposed for one hole faucet in 1 position
ohne Löcher, Vorrichtung für Einloch in 1 Position
sans trous avec possibilité d'un trou en 1 position
sin orificios, previsto orificio único en 1 posición
без отверстий, возможна однопозиционная установка с одним отверстием



senza fori, predisposizione monoforo in 2 posizioni
without faucet holes, predisposed for one hole faucet in 2 positions
ohne Löcher, Vorrichtung für Einloch in 2 Positionen
sans trous avec possibilité d'un trou en 2 positions
sin orificios, previsto orificio único en 2 posiciones
без отверстий, предусмотрена двухпозиционная установка с одним отверстием



senza fori, predisposizione monoforo in 3 posizioni
without faucet holes, predisposed for one hole faucet in 3 positions
ohne Löcher, Vorrichtung für Einloch in 3 Positionen
sans trous avec possibilité d'un trou en 3 positions
sin orificios, previsto orificio único en 3 posiciones
без отверстий, предусмотрена трехпозиционная установка с одним отверстием



solo vaso
Wc only
nur Klosett
cuvette seulement
sólo inodoro
только чаща



abbinabile a MONOLITH
combinable with MONOLITH
mit MONOLITH kombinierbar
possibilité d'associer à MONOLITH
combinable con MONOLITH
в комбинации с бачком MONOLITH



sedile incluso
seat cover included
Sitz inbegriffen
abattant compris
asiento incluido
с сиденьем



sedile frenato incluso
soft close seat cover included
gebremster Sitz inbegriffen
abattant avec système de frein de chute
abattant
asiento con caída amortiguada incluido
с сиденьем и системой плавного закрывания крышки



sospeso
suspended
hängend
suspendu
подвесной



in appoggio
surface-mounted
Aufsatz
à bord apparent
de apoyo
приставной



semincasso
half-built in
Halbeinbau
semi-encasté
semiempotrado
полувстраиваемый



incasso
built in
Einbau
à bord de vasque apparent
empotrado
встраиваемый



incasso sottopiano
built under
Einbau unter der Fläche
à vasque intégrée
empotrado bajo encimera
встраиваемый под столешницу



base rettificata per appoggio su piano
rectified surface for support on plan
für Unterstützung auf Piano berichtigt Basis
rectifiés pour pose à bord de vasque apparent
surplan de toilette
rectificado para apoyo sobre encimera
с регулировкой для напольного монтажа



su mobile
on a furniture
auf Möbel
sur meuble
sobre mueble
встраиваемый в мебель



su mobile A-WOOD
on A-WOOD furniture
auf Möbel A-WOOD
sur meuble A-WOOD
sobre mueble A-WOOD
встраиваемый в мебель A-WOOD



su base lavabo SLIDING WOOD SYSTEM
on SLIDING WOOD SYSTEM sink base unit
auf SLIDING WOOD SYSTEM
sur SLIDING WOOD SYSTEM
sobre SLIDING WOOD SYSTEM
встраиваемый в мебель SLIDING WOOD SYSTEM



con base SLIDING WOOD SYSTEM
with SLIDING WOOD SYSTEM side unit
mit SLIDING WOOD SYSTEM seitliches Möbel
avec SLIDING WOOD SYSTEM meuble côté
con SLIDING WOOD SYSTEM mueble lateral
со шкафом SLIDING WOOD SYSTEM



scarico a terra variabile
adjustable floor trap
senkrechten oder waagerechtem Abgang
vidange au sol allant
descarga de tierra variable
Я разгружаюсь к изменению земли



easywam®



vaso scarico a parete
WC with wall outlet
Klosett mit Abfluss an der Wand
cuvette avec chasse d'eau murale
inodoro descarga a pared
унитаз со сливом в стену



vaso scarico a terra
WC with floor outlet
Klosett mit Abfluss auf dem Boden
cuvette avec chasse d'eau avec vidange au sol
inodoro descarga a suelo
унитаз со сливом в пол



cassetta entrata acqua laterale alta (dx/sx)
high side water inlet cistern (rh/lh)
Spülkasten mit Wasseranschluss oben seitlich (rechts/links)
chasse d'eau avec arrivée d'eau latérale par le haut (droite/gauche)
cisterna entrada agua lateral alta (dcha./izqda.)
сливной бачок с боковым подводом воды (правый/левый)



cassetta entrata acqua dal basso (sx)
bottom water inlet cistern (lh)
Spülkasten mit Wasseranschluss von unten (links)
chasse d'eau avec arrivée d'eau par le bas (gauche)
cisterna entrada agua desde abajo (izqda.)
сливной бачок с нижним подводом воды (левый)



cassetta entrata acqua laterale alta (dx/sx) con meccanismo doppio scarico 3/6 L incluso
high side water inlet cistern (rh/lh) with 3/6 L dual flush mechanism included
Spülkasten mit Wasseranschluss oben seitlich (rechts/links) mit doppelem Spülmechanismus 3/6 L inbegriffen
chasse d'eau avec arrivée d'eau latérale par le haut (droite/gauche) avec mécanisme à double touche réglable à 3 ou 6 litres
cisterna entrada agua lateral alta (dcha./izqda.) con mecanismo de doble descarga de 3/6 litros incluido
сливной бачок с высоким боковым подводом воды (правый/левый) с механизмом двойного слива, объем 3/6 л



cassetta entrata acqua dal basso (sx) con meccanismo doppio scarico 3/6 L incluso
bottom water inlet cistern (lh) with 3/6 L dual flush mechanism included
Spülkasten mit Wasseranschluss von unten (links) mit doppelem Spülmechanismus 3/6 L inbegriffen
chasse d'eau avec arrivée d'eau par le bas (gauche) avec mécanisme à double touche réglable à 3 ou 6 litres
cisterna entrada agua desde abajo (izqda.) con mecanismo de doble descarga de 3/6 litros incluido
сливной бачок с нижним подводом воды (левый) с механизмом двойного слива, объем 3/6 л



cassetta entrata acqua posteriore con meccanismo doppio scarico 3/6 L incluso
back water inlet cistern with 3/6 L dual flush mechanism included
Spülkasten mit Wasseranschluss hinten mit doppelem Spülmechanismus 3/6 L inbegriffen
chasse d'eau avec arrivée d'eau fixation postérieure avec mécanisme à double touche réglable à 3 ou 6 litres
cisterna entrada agua posterior con mecanismo de doble descarga de 3/6 litros incluido
сливной бачок с задним подводом воды с механизмом двойного слива, объем 3/6 л



scarico utile 4,5 lt
4.5 litre flush
Spülung 4,5l
quantité d'eau 4,5 litres
descarga útil de 4,5 litros
полезный слив 4,5 литра

LETTURA DEL CATALOGO

CATALOGUE READING TEXT TEXT LEKTÜRE DES KATALOGS TEXTE LECTURE DU CATALOGUE
TEXTO PARA LECTURA DEL CATÁLOGO ТЕКСТ КАТАЛОГА

G-75

serie
series
serie
serie
serie
серия

testo descrittivo
description
Beschreibung
description
texto descriptivo
описательный текст

schemi di posa
installation layouts
Verlegungspläne
calepinages
esquemas de colocación
установочные схемы

modalità installazione
installation modes
Installationsmodalität
méthodes d'installation
modalidad de instalación
условия монтажа

simbologia
key
symbolbeschreibung
symboles
simbologia
система условных обозначений

foto zenitale prodotto
product zenith photo
Foto des Produkts von oben
photo zénithale du produit
foto cenital del producto
снимок изделия (вид сверху)

esploso accessori correlati
correlated accessories
exploded view
Explosionszeichnung
Zubehör
vue éclatée des accessoires
assortis
dibujo de despiece de
accesorios asociados
взрыв-схема
комплектующих







Eccellenza ed esperienza

Excellence and experience
Qualität und Kompetenz
Excellence et expérience
Excelencia y experiencia
Превосходство и опыт



Tradizione ceramica internazionale

INTERNATIONAL CERAMICS TRADITION
INTERNATIONALE KERAMIKTRADITION
TRADITION CÉRAMIQUE INTERNATIONALE
TRADICIÓN CERÁMICA INTERNACIONAL
МЕЖДУНАРОДНЫЕ КЕРАМИЧЕСКИЕ ТРАДИЦИИ

La tradizione e l'esperienza di Hatria, un marchio storico che è parte del Gruppo Marazzi, leader mondiale nella produzione e commercializzazione di prodotti ceramici, si rinnova attraverso la ricerca formale e l'innovazione.

Tutto nasce da una solida tradizione ceramica, da un "saper fare" che nel tempo si è affiancato a sempre più sofisticate tecnologie produttive: la ceramica è la protagonista delle collezioni Hatria, generatrice di infinite soluzioni per il mondo del bagno dal design esclusivo.

La tradition et l'expérience de Hatria, une marque légendaire incorporée au Groupe Marazzi, figure de proue internationale dans la fabrication et la vente de la céramique, se renouvellent avec la recherche sur les formes et avec l'innovation.

À la base, une extraordinaire tradition céramique, un « savoir-faire » qui a toujours su s'associer aux technologies de production les plus sophistiquées. La céramique est la vedette des collections Hatria, créatrice d'une multitude de solutions pour les salles de bains de classe.

The tradition and experience of Hatria, a historic brand belonging to the Marazzi Group, world leader in the production and sale of ceramic products, is constantly renewed by fresh design ideas and innovation.

This is all founded on a solid ceramics tradition, skills that have been backed up over time by more and more sophisticated production technology: ceramics are central to the Hatria collections, generating infinite solutions for the bathroom world, with exclusive design.

La tradición y la experiencia de Hatria, una marca histórica que forma parte del Grupo Marazzi, líder mundial en la producción y comercialización de productos cerámicos, se renueva a través de la investigación formal y la innovación.

Todo ello nace de una sólida tradición cerámica, de un "saber hacer" que a lo largo del tiempo se ha ido sirviendo de tecnologías productivas cada vez más sofisticadas: la cerámica es la protagonista de las colecciones de Hatria, generadora de un sinfín de soluciones de diseño exclusivo para el mundo del baño.

Design und Innovation durch Tradition und Kompetenz. So lautet das Zukunftskonzept der Marke Hatria, die sich als historisches Unternehmen der Marazzi Gruppe, Marktführer in der Herstellung und im Vertrieb von keramischen Produkten, etabliert hat. Die Grundpfeiler ihrer Entwicklung sind eine langjährige Tradition in der Keramikbranche und ein Know-how, das schrittweise mit den modernsten Fertigungstechniken ergänzt wurde. Im Mittelpunkt der Kollektionen von Hatria steht die Keramik, die unendlich viele Gestaltungslösungen für exklusive Badwelten bietet.

Брэнд Hatria имеет долгую историю и входит в состав Группы Marazzi, мирового лидера в производстве и сбыте керамических изделий. Традиции и опыт Hatria постоянно обновляются за счет изыскания новых форм и модернизации производства.

Все начиналось с прочных традиций керамического мастерства, с ремесла, которое со временем зашагало в ногу с все более совершенными технологиями производства. Керамика является главным героем коллекций Hatria, автора неисчислимых идей в сфере эксклюзивного дизайна ванных комнат.

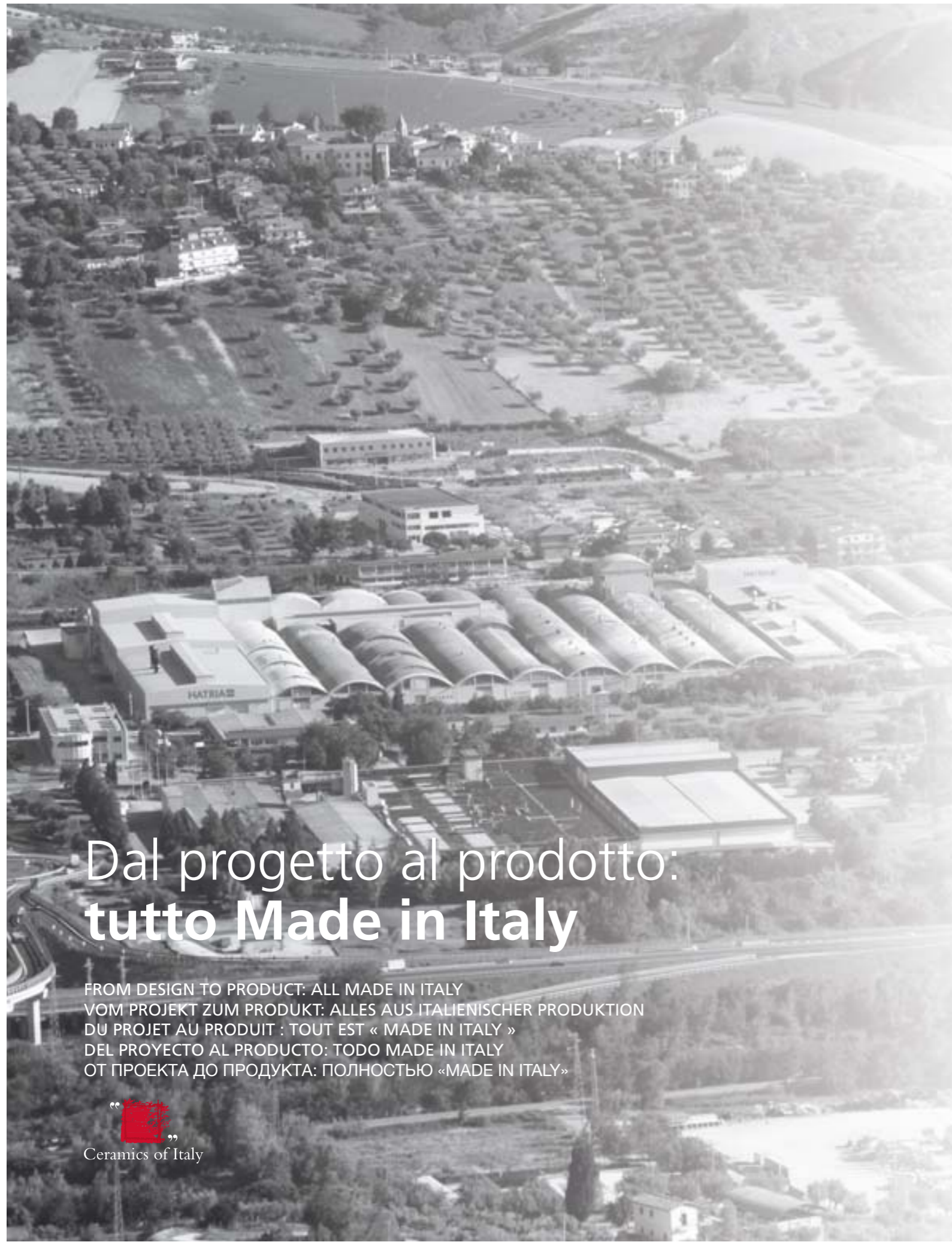

Dal progetto al prodotto: tutto Made in Italy

FROM DESIGN TO PRODUCT: ALL MADE IN ITALY
VOM PROJEKT ZUM PRODUKT: ALLES AUS ITALIENISCHER PRODUKTION
DU PROJET AU PRODUIT : TOUT EST « MADE IN ITALY »
DEL PROYECTO AL PRODUCTO: TODO MADE IN ITALY
ОТ ПРОЕКТА ДО ПРОДУКТА: ПОЛНОСТЬЮ «MADE IN ITALY»



Design ad alta tecnologia

High-tech design
Design und Hightech
Design hi-tech
Diseño de alta tecnología
Высокотехнологичный дизайн



Essenzialità ed ergonomia delle forme, qualità dei materiali, design innovativo e produzione rigorosamente Made in Italy, caratterizzano l'offerta di Hatria. La tradizione lascia spazio all'innovazione proiettando l'azienda verso mercati internazionali, grazie ad una offerta ampia e diversificata di soluzioni che incontrano il gusto di un pubblico eterogeneo, attento alla qualità e al design dei prodotti. Grandi investimenti nello sviluppo di sofisticate tecnologie realizzati negli ultimi anni, rendono Hatria una delle aziende più all'avanguardia del settore.

Hatria propose des formes sobres et ergonomiques, des matériaux de première qualité, un design original et une fabrication 100% Made in Italy. La tradition se laisse séduire par l'innovation, et armée de son offre variée et bigarrée qui capte l'attention d'un public hétéroclite sensible à la qualité et au design, la société se lance à la conquête des marchés internationaux. Les grands investissements de ces dernières années ont permis à Hatria de mettre au point des technologies exceptionnelles et de devenir l'une des sociétés les plus avant-gardistes du secteur.

Elegant, practical shapes, quality of materials and all-Italian innovative design and production are all found in the Hatria offering. Tradition gives way to innovation, projecting the company towards international markets, thanks to a wide, diversified offering of solutions to delight the taste of a variegated consumer market alert to products' quality and design. Major investments of recent years in the development of sophisticated technologies place Hatria at the state of the art in its industry.

La mesura y la ergonomía en las formas, la calidad en los materiales, un diseño innovador y una producción rigurosamente Made in Italy caracterizan la oferta de Hatria. La tradición deja la máxima libertad al espíritu de innovación para lanzar a la empresa a los mercados internacionales ofreciendo una amplia y diversificada gama de soluciones, capaz de satisfacer los gustos de un público heterogéneo especialmente exigente en lo que se refiere a la calidad y el diseño de los productos. Las grandes inversiones realizadas en los últimos años para propiciar el desarrollo de sofisticadas tecnologías sitúan a Hatria en la vanguardia de las empresas del sector.

Schlichte, ergonomische Formen, hochwertige Rohstoffe, innovatives Design und einhundertprozentig italienische Produktion sind die besonderen Kennzeichen der Erzeugnisse von Hatria. Mit Tradition und Innovation hat sich das Unternehmen die internationalen Märkte erschlossen. Sein umfassendes, vielfältiges Lösungsangebot trifft die Geschmacksvorstellungen einer heterogenen Kundschaft, die auf Produktqualität und -design Wert legt. Umfassende Investitionen in die Entwicklung von neuen Technologien machen Hatria zu einem Wegbereiter der Branche.

Практичность и эргономичность форм, качество материалов, современный дизайн и производство непременно в Италии - все это является отличительными особенностями бренда Hatria. Традиции уступают место инновациям, за счет чего бренд выходит на международный рынок, широкий спектр и разнообразность предлагаемых идей отвечает запросам различных категорий потребителей, уделяющих особое внимание качеству и дизайну изделий. За счет крупных вложений в развитие современных технологий за последние несколько лет Hatria стало одним из самых передовых предприятий в своей отрасли.



Una qualità progettata

Design for quality
Planungsqualität
Une qualité bien pensée
Calidad proyectada
Курс на качество



Tecnologia all'avanguardia

LEADING-EDGE TECHNOLOGY
FORTSCHRITTLICHE TECHNOLOGIE
TECHNOLOGIE D'AVANT-GARDE
TECNOLOGÍA DE VANGUARDIA
ПЕРЕДОВЫЕ ТЕХНОЛОГИИ

Hatria ha investito grandi risorse e tecnologie in un percorso di ricerca che parte dal progetto del sanitario, con la collaborazione di progettisti protagonisti del design internazionale, per evolversi e concretizzarsi in prodotti finiti all'insegna della massima qualità. Utilizzo di materie prime purissime, prototipazione accurata e rigorosa, controllo delle finiture e gestione di tutte le fasi del processo produttivo, si sviluppano nei nostri stabilimenti con l'ausilio di tecnologie all'avanguardia che rispondono alle rinnovate esigenze del bagno contemporaneo.

Hatria a consacré une grande quantité de ses ressources pécuniaires et matérielles à un travail de recherche qui a débuté par les sanitaires, avec la collaboration de quelques-uns des grands designers internationaux, puis a évolué et abouti à des produits finis d'une qualité exceptionnelle. Des matières premières ultra pures, des prototypes précis et définis, le contrôle des finitions et la gestion de l'ensemble du procédé de production, tout se fait au sein de nos usines avec des technologies de pointe qui répondent aux nouvelles exigences de la salle de bains contemporaine.

Hatria has invested impressive resources and technologies in research that starts from the design of the sanitary fitting itself, with the input of leading international designers, in a process that generates finished products of the very highest quality. The use of the purest raw materials, precise, meticulous prototyping, control of finishes and management of every phase of the production process all take place in-house, with the aid of leading-edge technologies that meet the renewed needs of the contemporary bathroom.

Hatria ha invertido abundantes recursos y tecnología en un proceso de investigación que arranca con el proyecto del sanitario, elaborado con la colaboración de proyectistas de renombre del diseño internacional, y evoluciona para llegar hasta el resultado final constituido por unos productos acabados que se distinguen por su extraordinaria calidad. La utilización de materias primas puras, la meticolosa y rigurosa realización de prototipos, el control de los acabados y la gestión de cada una de las fases del proceso productivo se llevan a cabo en nuestros establecimientos con la ayuda de tecnologías de vanguardia que responden a las renovadas exigencias del baño contemporáneo.

Hatria investiert umfassende Ressourcen und bringt erstklassige Technologien zum Einsatz. Beginnend beim Projekt des Sanitärelements in Zusammenarbeit mit international bekannten Designern bis hin zur Entwicklung und Herstellung von Qualitätserzeugnissen. Die Verarbeitung von Rohstoffen mit höchstem Reinheitsgrad, die sorgfältige Prototypenentwicklung unter Anwendung strengster Kriterien, die Kontrolle der Oberflächen und die Steuerung aller Produktionsphasen erfolgen an unseren Standorten unter Einsatz von fortschrittlichen Technologien, die den Anforderungen des modernen Bades gerecht werden.

Hatria investìròvala bol'shie sredstva i tehnologii v process issledovaniya, nachinaya s proyektirovaniya sanitexnicheskogo oborudovaniya, pri uchastii peredovoykh dizaynerov mezhdunarodnogo urovnya, i zakanchivaya gotovoy produkcijey pod znakom vysshego kachestva. Ispol'zovanie chisteyshogo syr'ya, akkuratnoe i tochnoe izgotovlenie opytnykh obrazcov, kontrol' otdelki i vsex etapov proizvodstvennogo processa, osushchestvlyayutsya na nashix predpriyatiyax pri pomoshchi peredovoykh tehnologii, otvечayushchix novym potrebnostyam dizayna sovremennykh vannyykh komnat.



Benessere naturale: una ricerca sostenibile

NATURAL WELLBEING: SUSTAINABLE RESEARCH
 NATÜRLICHES WOHLBEFINDEN: EIN NACHHALTIGES ENGAGEMENT
 BIEN-ÊTRE NATUREL : UNE RECHERCHE DURABLE
 BIENESTAR NATURAL: UNA INVESTIGACIÓN SOSTENIBLE
 ЭКОЛОГИЧЕСКОЕ БЛАГОПОЛУЧИЕ: УСТОЙЧИВОЕ РАЗВИТИЕ



4,5 lt

HATRIA
MARAZZI GROUP

L'acqua: una risorsa preziosa

Water: a precious resource
 Wasser: Eine wertvolle Ressource
 L'eau : une ressource précieuse
 El agua: un bien precioso
 Вода как ценный ресурс



Hatria porta avanti la sua filosofia aziendale con un grande senso di rispetto e responsabilità verso le risorse che la natura ci ha messo a disposizione. Impianti automatici senza consumo di stampi in gesso e che quindi evitano l'inquinamento da smaltimento, un attento utilizzo delle fonti energetiche in tutte le fasi del processo produttivo, l'eliminazione del consumo di energia per il riscaldamento, si uniscono all'impegno di trovare soluzioni che permettano un risparmio del consumo d'acqua dei suoi apparecchi.

Hatria croit dur comme fer à sa philosophie : un profond respect et une grande sensibilité pour les ressources que Dame Nature a mis à notre disposition. Non seulement la société s'engage à trouver des solutions pour réduire sa consommation d'eau, mais elle dispose d'ores et déjà de systèmes automatiques qui n'utilisent plus de moules en plâtre, évitant ainsi la production de déchets et la pollution en décaoulant. De plus, elle rationalise l'utilisation des sources d'énergie au cours de son procédé de production, et elle ne consomme plus d'énergie pour chauffer ses bâtiments.

Hatria's corporate philosophy involves great respect and responsibility towards the resources nature has provided for us. Automatic plants with no consumption of plaster moulds, meaning no pollution from their disposal, intelligent use of energy sources in every phase of the production process, and the elimination of energy consumption for heating, combine with the commitment to finding solutions that reduce the amount of water used by the equipment.

Hatria aplica su filosofía empresarial con el máximo respeto y un enorme sentido de la responsabilidad para con los recursos que la naturaleza pone a nuestra disposición. Unas instalaciones automáticas que no requieren el empleo de moldes de yeso, evitando de este modo la contaminación debida a su eliminación, un atento uso de las fuentes energéticas en todas las fases del proceso productivo y la eliminación del consumo de energía para el calentamiento se suman al compromiso de hallar soluciones que permitan incrementar el ahorro en el consumo de agua de sus aparatos.

Die Marke Hatria setzt ihre Unternehmensphilosophie mit einem großen Respekt und Verantwortungsbewusstsein gegenüber den natürlichen Ressourcen um. Automatische Anlagen, die keine Gipsformen benötigen und folglich die Umwelt nicht durch die Entsorgung belasten, eine umsichtige Nutzung der Energiequellen in jeder einzelnen Phase des Herstellungsprozesses und der Entfall des Energieverbrauchs für die Heizung vereinen sich mit der Erforschung von Lösungen für die Einsparung von Prozesswasser.

Hatria ведет политику рационального и бережного использования природных ресурсов. Автоматическое оборудование, не предусматривающее использование гипсовых пресс-форм, и, таким образом, исключающее данный фактор загрязнения окружающей среды при утилизации отходов, аккуратное использование энергоресурсов на всех этапах производственного процесса, отказ от расходования энергии на отопление, а также поиск решений по снижению потребления воды на производстве.

A misura dei tuoi desideri

Tailored to your wishes
Auf Ihre Wünsche zugeschnitten
Vos désirs sont des ordres
A la medida de tus deseos
Мы выполняем ваши желания



Hatria costruisce sistemi per il bagno nel segno dell'innovazione: lineari, compatti e leggeri, dal design ricercato ma non invasivo per ottimizzare lo spazio e massimizzare le funzioni. Le collezioni Hatria rappresentano un esempio unico di sintesi tra forma, spazio, minime dimensioni e tipologie, pensate per un pubblico eterogeneo che potrà trovare con facilità la soluzione ottimale per il proprio bagno, grazie a una comunicazione rigorosa e sempre aggiornata, che rende l'approccio ai prodotti e alle collezioni immediato e di facile lettura.

Hatria amène l'innovation dans les salles de bains : sobriété, compacité et légèreté, un design à la fois raffiné et discret pour améliorer l'espace et optimiser son utilité pratique. Les collections Hatria proposent une synthèse extraordinaire entre forme, espace, petits volumes et genres. Elles s'adressent à un public hétérogène qui pourra facilement trouver la solution parfaite pour la salle de bains, grâce à une communication rigoureuse et à jour, qui donne une lecture facile et un clin d'œil immédiat sur les produits et les collections.

Hatria constructs genuinely innovative bathroom systems: streamlined, compact and lightweight, stylishly but discreetly designed, to optimise space and maximise functionality. The Hatria collections are a unique synthesis of form, space, minimal dimensions and types, conceived for a variegated consumer market, enabling everyone to easily find the ideal solution for their bathroom thanks to accurate, up-to-date communications offering an immediate, user-friendly approach to products and collections.

Hatria construye sistemas para el baño ateniéndose a los más avanzados criterios de innovación. Se trata de baños lineales, compactos y ligeros, de diseño sofisticado pero no invasivo que optimizan el uso del espacio y brindan la máxima funcionalidad. Las colecciones de Hatria constituyen un ejemplo único de síntesis entre forma, espacio, dimensiones mínimas y tipos concebidos para satisfacer a un público heterogéneo que podrá encontrar sin dificultad la solución ideal para su baño, gracias a una comunicación rigurosa y constantemente actualizada que hace que el acercamiento a los productos y las colecciones resulte inmediato y de fácil lectura.

Hatria produziert innovative Badsysteme: linear, kompakt und leicht. Sie verbinden ein elegantes, dezentes Design mit optimaler Raumnutzung und einem Höchstmaß an Funktionalität. Die Kollektionen von Hatria bilden eine einzigartige Synthese aus Form, Raum, Kompaktheit und Funktion. Für eine heterogene Kundschaft konzipiert, bieten sie für jedes Bad die optimale Lösung. Zu verdanken ist das einer strukturierten, stets aktuellen Kommunikation, die dem Interessenten die Produkte und Kollektionen unmittelbar und leicht verständlich erschließt.

Hatria производит оборудование для ванных комнат по последнему слову техники: простота линий, компактность и легкость форм, изысканный, но ненавязчивый дизайн позволяют оптимизировать пространство и обеспечивают максимальную практичность в использовании. Коллекции бренда Hatria представляют собой неповторимый пример единства формы, пространства, минимальных размеров и типов продукции, рассчитанных на различные категории потребителей, которые легко смогут подобрать оптимальное решение для своей ванной комнаты в подробных, постоянно обновляемых каталогах.

Comunicare e comprendere

COMMUNICATIONS AND UNDERSTANDING
KOMMUNIZIEREN UND VERSTEHEN
COMMUNIQUER ET COMPRENDRE
COMUNICAR Y COMPRENDER
ОБЩЕНИЕ И ПОНИМАНИЕ

Architettura per il bagno contemporaneo

ARCHITECTURES FOR THE CONTEMPORARY BATHROOM
 ARCHITEKTUREN FÜR DAS ZEITGENÖSSISCHE BADEZIMMER
 ARCHITECTURES POUR LA SALLE DE BAINS CONTEMPORAINE
 ARQUITECTURAS PARA EL BAÑO CONTEMPORANEO
 АРХИТЕКТУРНЫЕ РЕШЕНИЯ ДЛЯ СОВРЕМЕННОЙ ВАННОЙ КОМНАТЫ



Soluzioni per bagni piccoli e grandi

Solutions for large and small bathrooms
 Lösungen für kleine und große Bäder
 Des solutions pour les petites et pour les grandes salles de bains
 Soluciones para baños pequeños y grandes
 Решения для больших и маленьких ванных комнат



Un nuovo modo di concepire lo spazio bagno, sempre più luogo condiviso e in relazione con altri ambienti della casa. Astrazione e design raffinato vanno di pari passo con la funzionalità e la semplicità d'uso: Hatria costruisce lo spazio attraverso la forma del sanitario, sintesi funzionale e generatrice di soluzioni modulari da scegliere tra le innumerevoli proposte, per adattarsi a bagni di ogni personalità. Forme contemporanee, superfici nitide e compatte, sono declinate secondo una logica di sistema per dare massima libertà alla componibilità.

La salle de bains fait peau neuve. Cet espace est désormais plus ouvert et davantage lié aux autres pièces de la maison. L'abstraction et l'élégance côtoient l'utilité pratique et la facilité d'emploi. Pour donner corps à l'espace, Hatria utilise la forme des sanitaires, une synthèse fonctionnelle et génératrice de solutions modulaires. La société propose un choix varié pour s'adapter à tous les styles de salles de bains. Les formes contemporaines, les surfaces nettes et compactes suivent une logique de système qui donne une liberté d'expression totale à la modularité.

A new-concept bathroom, increasingly a shared area, blending into the other rooms in the home. Abstract, sophisticated design goes hand-in-hand with convenience and ease of use: Hatria defines space with the shape of its sanitary fittings, pure functionality and the core of modular composition options, adaptable to bathrooms of any personality. Contemporary forms and immaculate, compact surfaces are formulated into a logical system for unbeatable modularity.

Una nueva manera de concebir el ámbito del baño, entendido cada vez más como un lugar compartido y relacionado con los demás espacios del hogar. Abstracción y refinado diseño casan con la funcionalidad y la sencillez de uso: Hatria construye el espacio a través de la forma del sanitario, síntesis funcional y generadora de soluciones modulares que elegir entre un sinfín de propuestas para adaptarse a baños de todas las personalidades. Formas contemporáneas, superficies nítidas y compactas que se articulan de acuerdo con una lógica de sistema para dar la máxima libertad de composición modular.

Das Bad definiert sich neu: Es wird zu einem zunehmend gemeinschaftlich genutzten Raum, der in einer engen Wechselbeziehung mit den anderen Wohnräumen steht. Abstraktion und Design gehen mit Funktionalität und Benutzerfreundlichkeit einher: Hatria gestaltet den Raum über die Form des Sanitärelements, das Funktionalität und Modularität auf einen Nenner bringt. Ein mannigfaltiges Angebot für Bäder unterschiedlicher Stil- und Lebenswelten. Zeitgemäße Formen, klare und kompakte Flächen sind einer Systemlogik untergeordnet, die unendliche viele Kombinationsmöglichkeiten erschließt.

Новый подход к восприятию ванной комнаты, которая все чаще рассматривается в соотношении с другими помещениями дома. Абстрактность и изысканность дизайна идут рука в руку с практичностью и простотой в использовании: Hatria организует пространство через форму сантехники, модульные решения позволяют заказчику подбирать и сочетать отдельные изделия из многочисленного ассортимента, которые органично впишутся в интерьер ванной комнаты любого стиля. Современные формы, четкие и компактные поверхности, в соответствии с логикой системы призваны обеспечить максимальную гибкость при компоновке.



Innovazione, funzione emozione

INNOVATION, FUNCTIONALITY, SENSATION
 INNOVATION, FUNKTION, EMOTION
 INNOVATION, FONCTION, ÉMOTION
 INNOVACIÓN, FUNCIÓN Y EMOCIÓN
 ИННОВАЦИИ НА СЛУЖБЕ ЭМОЦИЙ



La ricerca di Hatria ha realizzato grandi innovazioni per il concetto di benessere. Piacere, calore, tattilità, diventano i nuovi parametri sensoriali con cui confrontarsi, attraverso la massima funzionalità in prodotti e soluzioni che diventano rivoluzionari per lo spazio bagno, caricandosi di nuovi significati estetici e formali. Lo spazio bagno si trasforma in un ambiente perfettamente progettato e costruito che razionalizza e velocizza le funzioni, lasciando più tempo all'emozione e al piacere del relax.

La recherche de Hatria a donné un grand coup de jeune au concept de bien-être. Les sens ont des nouveaux paramètres : plaisir, chaleur, douceur. Les produits et les solutions font le plein de fonctionnalité et révolutionnent l'univers de la salle de bains avec leurs nouvelles valeurs esthétiques et formelles. La salle de bains se transforme en un espace dessiné et construit à la perfection, qui rationalise et optimise son utilisation, qui laisse plus de temps à l'émotion et au plaisir de la détente.

Evoluzione di spazi e forme

Evolution of spaces and forms
 Die Entwicklung von Raum und Form
 Évolution des espaces et des formes
 Evolución de espacios y formas
 Эволюция пространства и форм



Hatria's research has generated major innovations for the concept of wellbeing. Pleasure, warmth and tactile appeal become the new sensory parameters to be reckoned with, attained through a groundbreaking functionality in products and solutions that revolutionise the bathroom with new aesthetic and formal meanings. The bathroom is transformed into a room designed and constructed to perfection, that rationalises and speeds up functional activities, leaving more time for emotional satisfaction and the pleasure of relaxation.

La investigación de Hatria ha llevado a la realización de grandes innovaciones a favor del bienestar. Placer, calor y tacto pasan a ser los nuevos parámetros sensoriales que hay que perseguir a través de la máxima funcionalidad en productos y soluciones que se convierten en revolucionarios para el ámbito del baño, adquiriendo nuevos significados estéticos y formales. El ámbito del baño se transforma en un espacio perfectamente proyectado y construido que racionaliza y agiliza las funciones, dejando más tiempo para la emoción y el placer del relax.

Aus der Entwicklung von Hatria entstanden innovative Lösungen für das Wellness-Konzept. Wohlbefinden, Wohnlichkeit und Haptik gelten als der neue Maßstab der Sinne. Zweckmäßige Produkte und Lösungen revolutionieren das Bad mit neuen ästhetischen und gestalterischen Ideen. Das Bad verwandelt sich in einen perfekt geplanten und gestalteten Raum. Rationelle Funktionalität schafft mehr Zeit für Entspannung und Wohlbefinden.

Исследования Hatria позволили значительно видоизменить концепцию уюта. Удовольствие, тепло, тактильные ощущения становятся новыми параметрами, на которые следует ориентироваться, максимально практичные решения становятся революционными для ванных комнат, поскольку несут теперь также новую эстетическую нагрузку. Ванная комната превращается в идеально продуманное функциональное и практичное помещение, в котором остается больше места для приятного и комфортного отдыха.



G-Full: design per un nuovo comfort

G-FULL: DESIGN FOR NEW COMFORT
G-FULL: DESIGN FÜR NEUARTIGEN KOMFORT
G-FULL : DESIGN POUR UN CONFORT NOUVEAU
G-FULL: DISEÑO PARA UN NUEVO CONFORT
G-FULL: НОВАЯ КОНЦЕПЦИЯ КОМФОРТА



Qualità formali e tecnologiche

Quality in form and technology
Hochwertige Gestaltung und Technik
Qualité des formes et des technologies
Cualidades formales y tecnológicas
Конфигурация и технические особенности



G-Full® è un sistema di sanitari integrato e polifunzionale, un unico piano in ceramica che si trasforma in una comoda panca o in un ampio piano d'appoggio e che si relaziona con altri componenti per regalare continuità di spazio e funzione all'ambiente bagno. Trascorso il tempo del relax G-Full si apre e si trasforma in un'innovativo sanitario che integra le funzioni di vaso e bidet, coordinandosi ad una serie di panche e accessori, pensati per adattarsi a diverse configurazioni dello spazio bagno.

G-Full® est un système de sanitaires intégré et multifonction, un plan en céramique à même de se transformer en un pratique banc ou en un grand plan de travail. Il se fond avec le reste des éléments pour préserver l'harmonie de la salle de bains, tant au niveau de l'espace qu'au niveau de la fonction. Après la détente, G-Full s'ouvre pour devenir un produit original qui intègre les fonctions cuvette et bidet. Le système s'assortit à une série de bancs et d'accessoires faits pour s'aligner sur les différentes configurations de la salle de bains.

G-Full® is an integrated, multifunctional system of sanitary fittings, a single porcelain surface that offers a convenient bench or roomy counter and interacts with other furnishings to give the bathroom continuity of space and function. Once the time for relaxation is over, G-Full is transformed into an innovative sanitary fitting that combines the functions of WC and bidet, with a matching series of benches and accessories, tailored to adapt to various bathroom layouts.

G-Full® es un sistema de sanitarios integrado y multifuncional, una única superficie de cerámica que se transforma en un cómodo banco o en un amplio plano de apoyo y que se relaciona con los demás componentes para brindarle continuidad al espacio y funcionalidad al ámbito del baño. Una vez transcurrido el tiempo del relax G-Full se abre y se transforma en un innovador sanitario que aúna en un solo elemento las funciones de inodoro y bidet, coordinándose con una serie de bancos y accesorios pensados para adaptarse a diversas configuraciones del espacio del baño.

G-Full® ist in integriertes polyfunktionales Sanitärkeramiksystem. Das keramische Monoblock-Element kann sich in eine bequeme Sitzbank oder eine großzügige Ablagefläche verwandeln. Im Zusammenspiel mit anderen Badkomponenten sorgt es für eine geschlossene Raumgestaltung und höchstgradige Funktionalität. G-Full dient im geschlossenen Zustand als entspannende Sitz- und Ruhebänk und mit geöffneter Abdeckung als WC- und Bidet-Kombination. Das System ist mit zahlreichen Sitzbänken und Accessoires für die unterschiedlichsten Badkonfigurationen kombinierbar.

G-Full® - это встроенная многофункциональная сантехническая система. Цельная керамическая поверхность может служить в качестве удобной скамьи или просторной полки, органично сочетающейся с другими компонентами и обеспечивающей единство пространства и функций в интерьере ванной комнаты. При необходимости G-Full открывается и превращается в современную сантехнику, унитаз и биде, идеально сочетающуюся со скамьями и аксессуарами, разработанными для ванных комнат различных конфигураций.



l'espressione del
design



GRANDANGOLO

DESIGN NILO GIOACCHINI



G-150

Lavabo 150x50 cm sospeso a muro.
Installabile anche su mobile o con SLIDING WOOD SYSTEM. Integrabile con i ripiani in ceramica GRANDANGOLO 50 dx e sx, accessori portasciugamani e sifone estetico. Disponibile anche la versione con sistema easywarm® preinstallato.

Lavabo 150x50 cm suspendu au mur.
Installable aussi avec bord de vasque apparent sur meuble ou avec SLIDING WOOD SYSTEM. Intégrable dans un plan de toilette en céramique GRANDANGOLO 50 droit et gauche, équipé de porte-serviettes et de siphon esthétique. Existe aussi la version avec système easywarm® préinstallé.

Wall-hung lh and rh tapered washbasin, size 150x50 cm. Without holes. Can also be mounted on a custom-made furniture or SLIDING WOOD SYSTEM. Compatible with rh and lh GRANDANGOLO 50 shelves, towel holder accessories and aesthetic trap. Also available in version prefitted with easywarm® system.

Lavabo de 150x50 cm, suspendido en la pared. Se puede instalar también sobre un mueble o con SLIDING WOOD SYSTEM. Integrable con estantes de cerámica GRANDANGOLO 50 der e izq., con portatoalla y sifón estético. Disponible también en la versión con sistema easywarm® preinstalado.

Waschbecken 150x50 cm wandhängend. Zur Montage auch auf Badmöbeln oder mit SLIDING WOOD SYSTEM. Ergänztbar mit Keramikböden GRANDANGOLO 50 r. und l., mit Handtuchhalter und ästhetischen Siphon. Erhältlich auch in der mit easywarm® System vorinstallierten Version.

Подвесной настенный умывальник 150x50 см. Устанавливается также на тумбе или в сочетании с тумбой SLIDING WOOD SYSTEM. Комбинируются с керамическими правыми и левыми полками GRANDANGOLO 50, вешалками для полотенец и сифоном в эстетическом исполнении. Имеется также модель с встроенной системой обогрева easywarm®.

installazione installation

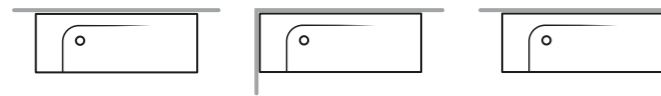

sospeso wall hung



su mobile on a custom-made furniture



con base SLIDING WOOD SYSTEM with SLIDING WOOD SYSTEM side unit

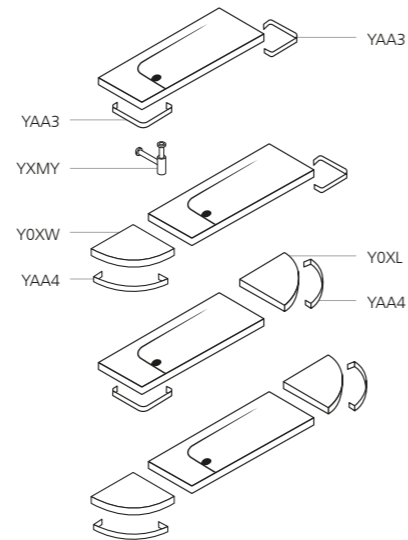
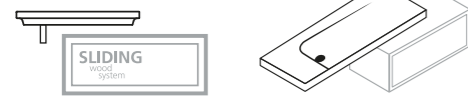

1500x500

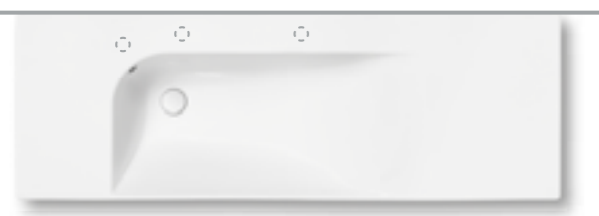



G-130 T

Lavabo Trapezoidale 130x50 cm dx e sx sospeso a muro. Installabile anche su mobile o con SLIDING WOOD SYSTEM. Integrabile con i ripiani in ceramica GRANDANGOLO 50 dx e sx, con portasciugamani e sifone estetico. Disponibile anche la versione con sistema easywarm® preinstallato.

Lavabo trapézoïdale de 130x50 cm droit et gauche suspendu au mur. Installable aussi avec bord de vasque apparent sur meuble ou avec SLIDING WOOD SYSTEM. Intégrable dans un plan de toilette en céramique GRANDANGOLO 50 droit et gauche, équipé de porte-serviettes et de siphon esthétique. Existe aussi dans la version avec système easywarm® préinstallé.

Wall-hung lh and rh tapered washbasin, size 130x50 cm. Can also be mounted on a custom-made furniture or with SLIDING WOOD SYSTEM. Can be combined with rh and lh GRANDANGOLO 50 shelves, towel holder and design siphon. Also available in version prefitted with easywarm® system.

Lavabo Trapezoidal de 130x50 cm, der. e izq., suspendido en la pared. Se puede instalar también sobre un mueble o con SLIDING WOOD SYSTEM. Integrable con estantes de cerámica GRANDANGOLO 50 der. e izq., con portatoalla y sifón estético. Disponible también en la versión con sistema easywarm® preinstalado.

Trapezförmiges Waschbecken 130x50 cm r. und l. wandhängend. Zur Montage auch auf Bademöbeln oder mit SLIDING WOOD SYSTEM. Ergänztbar mit den Keramikböden GRANDANGOLO 50 r. und l., Handtuchhaltern und ästhetischen Siphon. Erhältlich auch in der mit easywarm® System vorinstallierten Version.

Подвесной настенный трапециевидный умывальник 130x50 см правосторонний и левосторонний. Устанавливается также на тумбе или в сочетании с тумбой SLIDING WOOD SYSTEM. Комбинируется с керамическими правыми и левыми полками GRANDANGOLO 50, вешалками для полотенец и сифоном в эстетическом исполнении. Имеется также модель с встроенной системой обогрева easywarm®.

installazione
installation

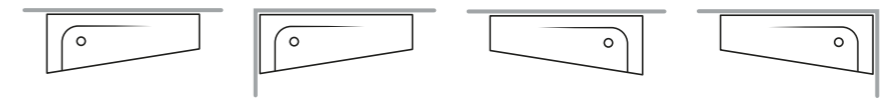

sospeso
wall hung

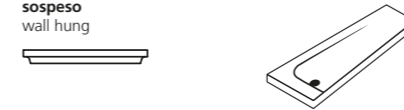

su mobile
on a custom-made furniture

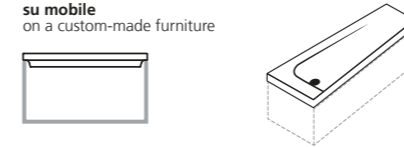

con base SLIDING WOOD SYSTEM
with SLIDING WOOD SYSTEM side unit

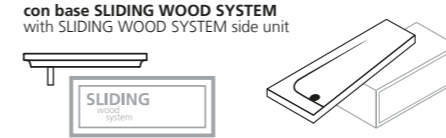

YXF5
YOYF
YOXT

easywarm®

1300x500 dx - rh

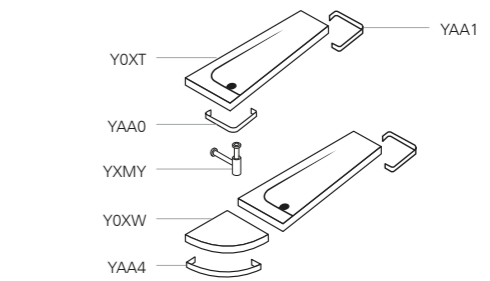

Y0V0

YAA2

YXMY

Y0V0

YAA2

YXF6
Y0V1
Y0V0

easywarm®

1300x500 sx - lh



G-130

Lavabo 130x50 cm sospeso a muro. Installabile anche su mobile o con SLIDING WOOD SYSTEM. Integrabile con i ripiani in ceramica GRANDANGOLO 50 dx e sx, con portasciugamani e sifone estetico. Disponibile anche la versione con sistema easywarm® preinstallato.

Lavabo 130x50 cm suspendu au mur. Installable aussi avec bord de vasque apparent sur meuble ou avec SLIDING WOOD SYSTEM. Intégrable dans un plan de toilette en céramique GRANDANGOLO 50 droit et gauche, équipé de porte-serviettes et de siphon esthétique. Existe aussi la version avec système easywarm® préinstallé.

Wall-hung washbasin, size 130x50 cm. Can also be mounted on a custom-made furniture or with SLIDING WOOD SYSTEM. Can be combined with rh and lh GRANDANGOLO 50 shelves, towel holder and design siphon. Also available in version prefitted with easywarm® system

Lavabo de 130x50 cm, suspendido en la pared. Se puede instalar también sobre un mueble o con SLIDING WOOD SYSTEM. Integrable con estantes de cerámica GRANDANGOLO 50 der e izq., con portatoalla y sifón estético. Disponible también en la versión con sistema easywarm® preinstalado.

Waschbecken 130x50 cm wandhängend. Zur Montage auch auf Badmöbeln oder mit SLIDING WOOD SYSTEM. Ergänztbar mit Keramikböden GRANDANGOLO 50 r. und l., mit Handtuchhalter und ästhetischen Siphon. Erhältlich auch in der mit easywarm® System vorinstallierten Version.

Подвесной настенный умывальник 130x50 см. Устанавливается также на тумбе или в сочетании с тумбой SLIDING WOOD SYSTEM. Комбинируются с керамическими правыми и левыми полками GRANDANGOLO 50, вешалками для полотенец и сифоном в эстетическом исполнении. Имеется также модель с встроенной системой обогрева easywarm®.

installazione installation

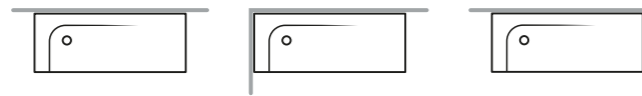

sospeso wall hung

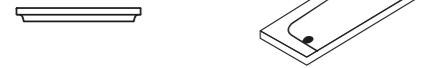

su mobile on a custom-made furniture



con base SLIDING WOOD SYSTEM with SLIDING WOOD SYSTEM side unit

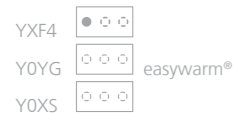
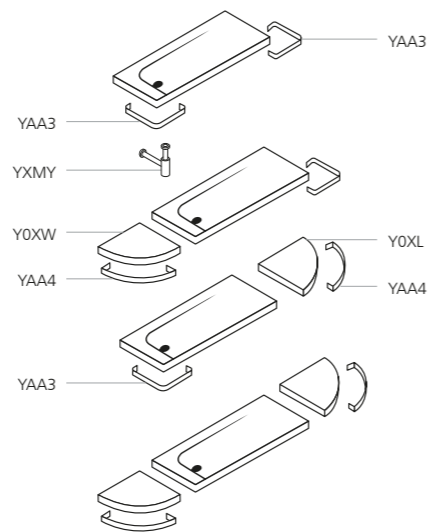

1300x500

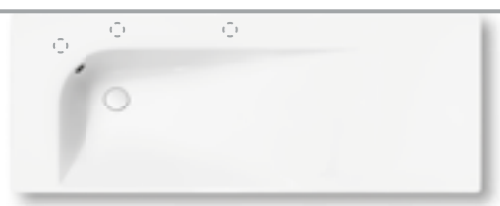



G-100

Lavabo 100x50 cm sospeso a muro.
Installabile anche su mobile o con SLIDING WOOD SYSTEM. Integrabile con i ripiani in ceramica GRANDANGOLO 50 dx e sx, accessori portasciugamani e sifone estetico.

Lavabo 100x50 cm suspendu au mur.
Installable aussi avec bord de vasque apparent sur meuble ou avec SLIDING WOOD SYSTEM. Intégrable dans un plan de toilette en céramique GRANDANGOLO 50 droit et gauche, équipé de porte-serviettes et de siphon esthétique.

Wall-hung washbasin, size 100x50 cm. Can also be mounted on a custom-made furniture or with SLIDING WOOD SYSTEM. Can be combined with rh and lh GRANDANGOLO 50 shelves, towel holder and design siphon.

Lavabo de 100x50 cm, suspendido en la pared. Se puede instalar también sobre un mueble o con SLIDING WOOD SYSTEM. Integrable con estantes de cerámica GRANDANGOLO 50 der e izq., con portatoalla y sifón estético.

Waschbecken 100x50 cm wandhängend. Zur Montage auch auf Bademöbeln oder mit SLIDING WOOD SYSTEM. Ergänzzbar mit Keramikböden GRANDANGOLO 50 r. und l., mit Handtuchhalter und ästhetischen Siphon.

Подвесной настенный умывальник 100x50 см. Устанавливается также на тумбе или в сочетании с тумбой SLIDING WOOD SYSTEM. Комбинируются с керамическими правыми и левыми полками GRANDANGOLO 50, вешалками для полотенец и сифоном в эстетическом исполнении.

installazione
installation

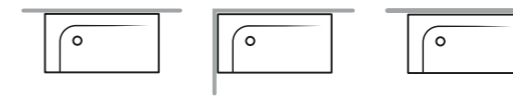

sospeso
wall hung



su mobile
on a custom-made furniture



su base lavabo SLIDING WOOD SYSTEM
on SLIDING WOOD SYSTEM sink base unit



con base SLIDING WOOD SYSTEM
with SLIDING WOOD SYSTEM side unit



YXF7
Y0VA

1000x500

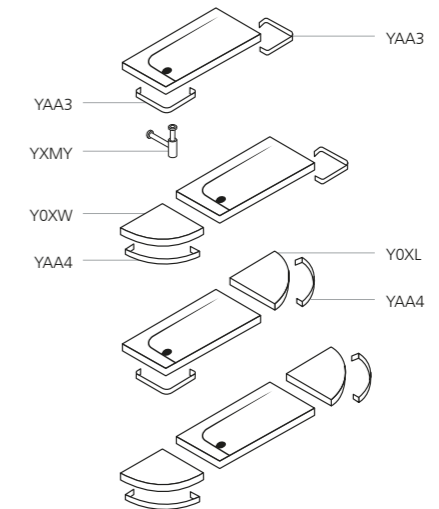

G-75

Lavabo 75x50 cm dx e sx sospeso a muro. Installabile anche su mobile, con SLIDING WOOD SYSTEM o in appoggio su piano. Integrabile con i ripiani in ceramica GRANDANGOLO 50 dx e sx, accessori portasciugamani e sifone estetico.

Lavabo 75x50 cm droit et gauche suspendu au mur. Installable avec bord apparent sur meuble, avec SLIDING WOOD SYSTEM ou sur plan de toilette. Intégrable dans un plan de toilette en céramique GRANDANGOLO 50 droit et gauche, équipé de porte-serviettes et de siphon esthétique.

Wall-hung lh and rh washbasin, size 75x50 cm. Can also be mounted on a custom made custom-made furniture, with SLIDING WOOD SYSTEM or mounted on a surface. Can be combined with rh and lh GRANDANGOLO 50 shelves, towel holder and design siphon.

Lavabo 75x50 cm. der. e izq. suspendido en la pared. También se puede instalar sobre un mueble, con SLIDING WOOD SYSTEM o apoyado sobre una encimera. Integrable con estantes de cerámica GRANDANGOLO 50 der. e izq., con portatoalla y sifón estético.

Waschbecken 75x50 cm r. und l. wandhängend. Kann auch auf Badmöbeln installiert werden, mit SLIDING WOOD SYSTEM oder aufliegend. Ergänzzbar mit Keramikböden GRANDANGOLO 50 r. und l., Handtuchhaltern und ästhetischem Siphon.

Подвесной настенный умывальник 75x50 см правосторонний и левосторонний. Устанавливается также на тумбе, в сочетании с тумбой SLIDING WOOD SYSTEM, на полке или. Комбинируются с керамическими правыми и левыми полками GRANDANGOLO 50, вешалками для полотенец и сифоном в эстетическом исполнении.

installazione installation

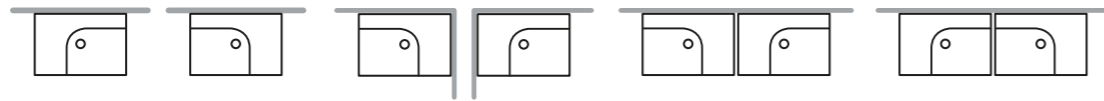

sospeso wall hung



in appoggio surface mounted

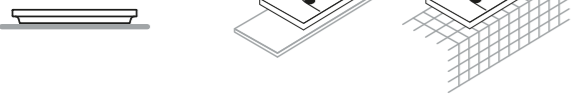

su mobile on a custom-made furniture



su base lavabo SLIDING WOOD SYSTEM on SLIDING WOOD SYSTEM sink base unit



con base SLIDING WOOD SYSTEM with SLIDING WOOD SYSTEM side unit

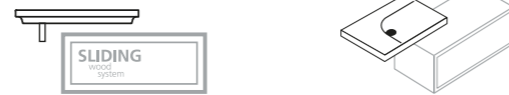

750x500 dx - rh



750x500 sx - lh

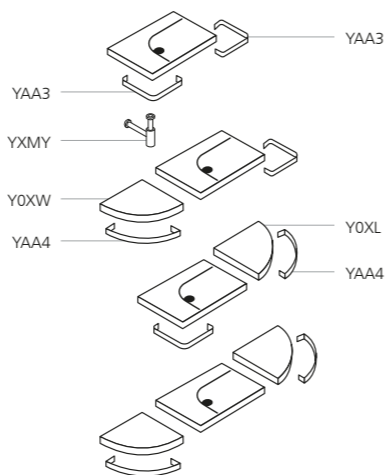



G-50

Lavabo 50x50 cm dx e sx sospeso a muro. Installabile anche su mobile, con SLIDING WOOD SYSTEM o in appoggio su piano. Integrabile con i ripiani in ceramica GRANDANGOLO 50 dx e sx, accessori portasciugamani e sifone estetico.

Wall-hung lh and rh washbasin, size 50x50 cm. Can also be mounted on a custom made furniture, with SLIDING WOOD SYSTEM or mounted on a surface. Can be combined with rh and lh GRANDANGOLO 50 shelves, towel holder and design siphon.

Waschbecken 50x50 cm r. und l. wandhängend. Kann auch auf Badmöbeln installiert werden, mit SLIDING WOOD SYSTEM oder aufliegend. Ergänzung mit Keramikböden GRANDANGOLO 50 r. und l., Handtuchhaltern und ästhetischem Siphon.

Lavabo 50x50 cm droit et gauche suspendu au mur. Installable avec bord apparent sur meuble, avec SLIDING WOOD SYSTEM ou sur plan de toilette en céramique GRANDANGOLO 50 droit et gauche, équipé de porte-serviettes et de siphon esthétique.

Lavabo 50x50 cm. der. e izq. suspendido en la pared. También se puede instalar sobre un mueble, con SLIDING WOOD SYSTEM o apoyado sobre una encimera. Integrable con estantes de cerámica GRANDANGOLO 50 der. e izq., con portatoalla y sifón estético.

Подвесной настенный умывальник 50x50 см правосторонний и левосторонний. Устанавливается также на тумбе, в сочетании с тумбой SLIDING WOOD SYSTEM, на полке. Комбинируются с керамическими правыми и левыми полками GRANDANGOLO 50, вешалками для полотенец и сифоном в эстетическом исполнении.

installazione
installation

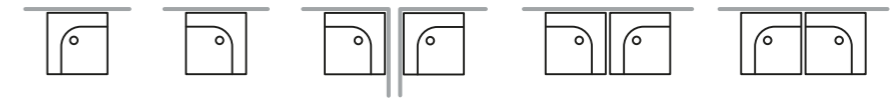

sospeso
wall hung



in appoggio
surface mounted

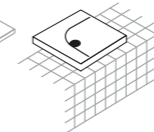
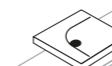

su mobile
on a custom-made furniture

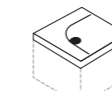

su base lavabo SLIDING WOOD SYSTEM
on SLIDING WOOD SYSTEM sink base unit

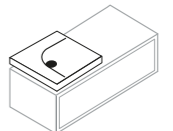

con base SLIDING WOOD SYSTEM
with SLIDING WOOD SYSTEM side unit

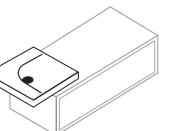

500x500 dx - rh



500x500 sx - lh

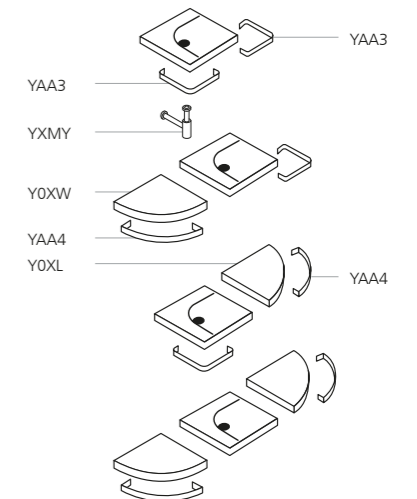

G-50

RIPIANO SHELF BODEN ETAGERE ESTANTE ПОЛКА

Ripiani in ceramica 50x50 cm dx e sx sospesi a muro. Con o senza sistema easywarm® preinstallato. Possono essere installati singolarmente oppure abbinati a tutti i lavabi Grandangolo. Integrabili con accessorio portasciugamani.

50x50 cm wall-hung ceramic shelves. With or without easywarm® system prefitted. Can be mounted singly or combined with all the Grandangolo washbasins. Can be combined with towel holder.

Keramikböden 50x50 cm r. und l. wandhängend. Mit oder ohne vorinstalliertem easywarm® System. Können einzeln oder in Kombination mit allen Waschbecken Grandangolo montiert werden. Ergänzzbar mit Zubehör Handtuchhaltern.

Étagère en céramique de 50x50 cm droit et gauche fixée au mur. Avec ou sans système easywarm® préinstallé. Installable individuellement ou bien associée à tous les lavabos Grandangolo. Intégrables avec l'accessoire porte-serviettes.

Estantes de cerámica de 50x50 cm, der.e izq. suspendidos en la pared. Con o sin sistema easywarm® preinstalado. Pueden ser instalados individualmente o bien, combinados con todos los lavabos Grandangolo. Integrables con accesorios o portatoalla.

Подвесные настенные правые и левые полки из керамики 50x50 см. С встроенной системой обогрева easywarm® или без нее. Могут устанавливаться отдельно или в сочетании со всеми умывальниками серии Grandangolo. Комбинируется с вешалкой для полотенец.

installazione
installation

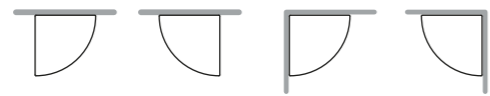

sospeso
wall hung

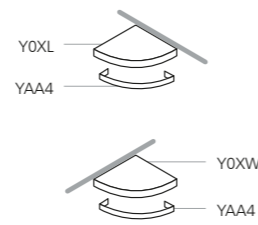
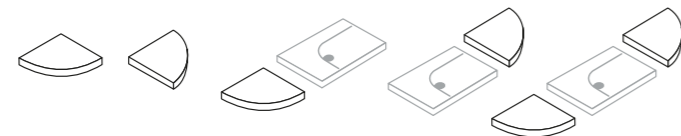

Y0YH easywarm®
Y0XL
500x500 dx - rh



Y0YL easywarm®
Y0XW
500x500 sx - lh



easywarm®



2008

easywarm® è il sistema di Hatria che, con un'originale innovazione tecnologica, permette di riscaldare le superfici ceramiche. Il nuovo calore diffuso dalla materia ceramica, fonde e climatizza l'insieme, realizzando un nuovissimo rapporto percettivo. Il sistema **easywarm®** si integra con elementi dei sistemi G-Full, Grandangolo ed Area.

easywarm® est le système conçu par Hatria qui, grâce à une innovation technologique particulièrement originale, permet de réchauffer toutes les surfaces céramiques : ce nouveau système de diffusion de la chaleur doucement diffusée par la matière céramique, parfonde et climatise le tout, dans la réalisation d'un tout nouveau rapport de perception. Le système **easywarm®** s'intègre avec des éléments des systèmes G-Full, Grandangolo et Area.

easywarm® is the Hatria system that uses an original, innovative technology to heat ceramic surfaces. The new warmth gently emitted by the ceramic material keeps the entire room at the ideal temperature and revolutionises perceptions. The **easywarm®** system combines with elements of the G-Full, Grandangolo and Area systems.

easywarm® es el sistema de Hatria que, con una original innovación tecnológica, permite calentar las superficies de cerámica. El nuevo calor difundido por la materia cerámica, climatiza todo el ambiente, creando una nueva relación perceptiva. El sistema **easywarm®** se integra con elementos de los sistemas G-Full, Grandangolo y Area.

easywarm® ist das System von Hatria, das durch eine originale technische Neuerung erlaubt, Keramikoberflächen zu beheizen. Die neue durch das Keramikmaterial verbreitete Wärme, bringt die Räumlichkeiten auf eine Temperatur und erzielt somit ein revolutionäres Wahrnehmungskonzept. Das **easywarm®** System lässt sich mit den Elementen der Systeme G-Full, Grandangolo und Area ergänzen.

Система **easywarm®** разработана компанией Hatria; с помощью оригинального технологического нововведения система обогревает керамические поверхности. Исходящее от керамики тепло отапливает и одновременно создает в помещении искусственный климат, создавая новые приятные ощущения. Система **easywarm®** комбинируется с элементами серий G-Full, Grandangolo и Area.

G-150
YXK8



50x50 sx-lh
YOYL



50x50 dx-rh
YOYH



G-130
YOYG



G-130T dx-rh
YOYF



G-130T sx-lh
YOY1





FUSION
DESIGN NILO GIOACCHINI



FUSION

bidet monoforo filo muro

Bidet completo di fissaggi per installazione a filo muro.

vaso scarico universale filo muro con sedile

Vaso scarico universale completo di sedile, curva tecnica di scarico e fissaggio. Installazione a filo muro. Può essere abbinato alle cassette Monolith.

bidet à un trou au ras du mur

Bidet avec kit de fixation pour installation au ras du mur.

cuvette vidange universelle ras du mur avec abattant

Cuvette vidange universelle avec siège, tuyau coudé de vidange et fixation. Installation au ras du mur. Elle peut être associée aux chasses d'eau Monolith.

back-to-wall one hole bidet

Back-to-wall bidet, complete with fixing elements.

back to wall wc with universal outlet and with seat cover

WC with universal outlet, complete with seat cover, U-bend and fixing elements. Back-to-wall installation. Compatible with Monolith cisterns.

bidé de un orificio contra la pared

Bidé completo de sistema de fijación para instalación contra la pared.

inodoro con descarga universal contra la pared completo de asiento

Inodoro con descarga universal completo de asiento, curva técnica de descarga y sistema de fijación. Instalación contra la pared. Puede ser combinado con las cisternas Monolith.

einlochbidet

Bidet inklusive Halterungen zur Wandmontage.

wc mit Universal Abgang komplett mit Sitz

Tiefspüler mit Universal Abgang, komplett mit Sitz, technischer Ablauf-Kurve und Halterung. Zur Wandmontage. Kombinierbar mit WC-Kasten Monolith.

биде с одним отверстием

Биде в комплекте с крепежом для пристенной установки.

Унитаз с универсальным сливом

Унитаз с универсальным сливом, в комплекте с сиденьем, сливным коленом и крепежом. Пристенная установка. Может комбинироваться со смывными бачками серии Monolith.



355x540



355x540



Y0U6



Y0U7
Y0XA





FUSION

+ MONOLITH

cassetta MONOLITH

Cassetta esterna in ceramica per installazione con vasi a filo muro. Meccanismo interno Geberit, doppio scarico 3/6 litri. Entrata acqua posteriore o laterale. Possibilità di installazione con scarico a terra variabile da 10 a 23 cm, oppure a parete.

chasse d'eau MONOLITH

Chasse d'eau extérieure en céramique pour installation avec cuvette au ras du mur. Mécanisme Geberit avec double touche avec possibilité de réglage à 3 ou 6 litres. Arrivée d'eau arrière ou latérale. Possibilité d'installation avec vidange au sol allant de 10 à 23 cm, ou bien murale.

MONOLITH Cistern

Ceramic cistern to be used with back-to-wall WCs. Geberit 3/6 litre inner mechanism with dual flush. Rear or side water inlet system Wall or floor outlet. The floor outlet can vary from 10 to 23 cm.

cisterna MONOLITH

Cisterna externa de cerámica para instalación de inodoros contra la pared. Mecanismo interno Geberit, doble descarga 3/6 litros. Entrada de agua posterior o lateral. Posibilidad de instalación con descarga de tierra variable de 10 a 23 cm, o bien, de pared.

MONOLITH Kasten

Vorwand Kasten in Keramik zur Wandmontage. Innen Mechanismus Geberit, Doppelspülung 3/6 l. Wassereingang rückwärtig oder seitlich. Montagemöglichkeit mit senkrechtem oder waagrechtem Abgang, senkrechter Abgang variiert von 10 bis 23 cm.

Бачок MONOLITH

Смывной керамический бачок для наружного монтажа к пристенным унитадам. Внутренний механизм Geberit, двойной слив 3-6 литров. Задний или боковой подвод воды. Возможна установка с регулируемым сливом в пол от 10 до 23 см или в стену.



370x670x900

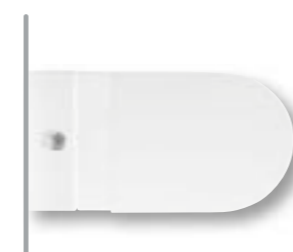

FUSION

bidet sospeso monoforo

Bidet sospeso completo di fissaggio speciale. Installazione con staffa universale per sospesi.

vaso sospeso con sedile

Vaso sospeso completo di sedile e fissaggio speciale. Installazione con staffa universale per sospesi.

bidet suspendu à un trou

Bidet suspendu avec kit de fixation spécial. Installation avec étrier universel pour éléments suspendus.

cuvette suspendu avec abattant

Cuvette suspendue dotée de abattant et fixation spéciale. Installation avec étrier universel pour éléments suspendus.

one hole wall hung bidet

One-hole wall hung bidet with special fixing included. Mounted using universal bracket for wall-hung elements

wall hung wc with seat cover

Wall-hung WC with seat cover and special fixing element included. Mounted using universal bracket for wall-hung elements.

Bidè suspendido

Bidè suspendido completo de sistema de fijación especial. Instalación con estribo universal para artefactos suspendidos.

Inodoro suspendido completo de asiento

Inodoro suspendido completo de asiento y sistema de fijación especial. Instalación con estribo universal para artefactos suspendidos.

einlochbidet wandhängend

Wand-Bidet inklusive spezieller Halterung. Zur Montage mit universeller Wand-Halterung.

hänge-Wc inklusive Sitz

Hänge-Wc inklusive Sitz und spezieller Halterung. Montage mit universeller Wandhalterung.

подвесное биде с одним отверстием

Подвесное биде в комплекте со специальным крепежом. Установка с универсальным кронштейном для подвесной сантехники.

Подвесной унитаз

Подвесной унитаз в комплекте с сиденьем и специальным крепежом. Установка с универсальным кронштейном для подвесной сантехники.



355x540



355x540



YOUX



YOXB
YOUU





FUSION Q

bidet sospeso monoforo

Bidet sospeso completo di fissaggio speciale. Installazione con staffa universale per sospesi.

vaso sospeso con sedile

Vaso sospeso completo di sedile e fissaggio speciale. Installazione con staffa universale per sospesi.

bidet suspendu à un trou

Bidet suspendu avec kit de fixation spécial. Installation avec étrier universel pour éléments suspendus.

cuvette suspendu avec abattant

Cuvette suspendue dotée de abattant et fixation spéciale. Installation avec étrier universel pour éléments suspendus.

one hole wall hung bidet

One-hole wall hung bidet with special fixing included. Mounted using universal bracket for wall-hung elements.

wall hung wc with seat cover

Wall-hung WC with seat cover and special fixing element included. Mounted using universal bracket for wall-hung elements.

Bidè suspendido

Bidè suspendido completo de sistema de fijación especial. Instalación con estribo universal para artefactos suspendidos.

Inodoro suspendido completo de asiento

Inodoro suspendido completo de asiento y sistema de fijación especial. Instalación con estribo universal para artefactos suspendidos.

einlochbidet wandhängend

Wand-Bidet inklusive spezieller Halterung. Zur Montage mit universeller Wand-Halterung.

hänge-Wc inklusive Sitz

Hänge-Wc inklusive Sitz und spezieller Halterung. Montage mit universeller Wandhalterung.

подвесное биде с одним отверстием

Подвесное биде в комплекте со специальным крепежом. Установка с универсальным кронштейном для подвесной сантехники.

Подвесной унитаз

Подвесной унитаз в комплекте с сиденьем и специальным крепежом. Установка с универсальным кронштейном для подвесной сантехники.



350x530



355x530



YXC0



YXBX
YXBV



FUSION 48

bidet sospeso monoforo

Bidet sospeso completo di fissaggio speciale. Installazione con staffa universale per sospesi.

vaso sospeso con sedile

Vaso sospeso completo di sedile frenato a sgancio rapido e fissaggio speciale. Installazione con staffa universale per sospesi.

bidet suspendu à un trou

Bidet suspendu avec kit de fixation spécial. Installation avec étrier universel pour éléments suspendus.

cuvette suspendue avec abattant

Cuvette suspendue avec abattant avec système frein de chute abattant à déclenchement rapide et kit de fixation spéciale. Installation avec étrier universel pour éléments suspendus.

one-hole wall hung bidet

One-hole wall hung bidet with special fixing included. Mounted using universal bracket for wall-hung elements.

wall hung wc with soft close seat cover

Wall hung wc with soft close seat cover, and special fixing included.

bidè suspendido

Bidè suspendido completo de sistema de fijación especial. Instalación con estribo universal para artefactos suspendidos.

inodoro suspendido completo de asiento

Inodoro suspendido completo de asiento frenado de desenganche rápido y sistema de fijación especial. Instalación con estribo universal para artefactos suspendidos.

einlochbidet wandhängend

Wand-Bidet inklusive spezieller Halterung. Zur Montage mit universeller Wand-Halterung.

hänge-WC inklusive Sitz

Hänge-WC inklusive softclose-Sitz schnell abnehmbar und mit spezieller Halterung. Montage mit universeller Wandhalterung.

подвесное биде с одним отверстием

Подвесное биде в комплекте со специальным крепежом. Установка с универсальным кронштейном для подвесной сантехники.

подвесной унитаз

Подвесной унитаз в комплекте с сиденьем с быстродействующим механизмом плавного опускания и специальным крепежом. Установка с универсальным кронштейном для подвесной сантехники.



350x480



350x480



YXJ8 



YXJ7  4,5lt





FUSION 48

bidet monoforo filo muro

Bidet completo di fissaggi per installazione a filo muro.

vaso scarico universale filo muro con sedile

Vaso scarico universale completo di sedile frenato a sgancio rapido, curva tecnica di scarico e fissaggio. Installazione a filo muro. Può essere abbinato alle cassette Monolith. Scarico utile 4,5 litri.

bidet à un trou au ras du mur

Bidet avec kit de fixation pour installation au ras du mur.

cuvette vidange universelle au ras du mur avec abattant

Cuvette vidange universelle avec siège avec système frein de chute abattant à déclenchement rapide, tuyau coudé de vidange et kit de fixation. Installation au ras du mur. Elle peut être associée aux chasses d'eau Monolith. Quantité d'eau 4,5 litres.

back-to-wall one hole bidet

Back-to-wall bidet, complete with fixing elements.

back-to-wall WC with universal outlet and seat cover

Back-to-wall universal outlet WC, compatible with Monolith cistern, complete with quick-release soft close seat. 4.5 litre flush.

bidé de un orificio contra la pared

Bidé completo de sistema de fijación para instalación contra la pared.

inodoro contra la pared con descarga universal completo de asiento

Inodoro con descarga universal, completo de asiento frenado de desenganche rápido, curva técnica de descarga y sistema de fijación. Instalación contra la pared. Puede ser combinado con las cisternas Monolith. Descarga útil de 4,5 litros

einlochbidet

Bidet inklusive Halterungen zur Wandmontage.

wc mit Universal Abgang inklusive Sitz

Wc mit Universal Abgang inklusive softclose-Sitz schnell abnehmbar, technischer Ablauf-Kurve und Halterung. Zur Wandmontage. Kombinierbar mit WC-Kasten Monolith. Spülung 4,5l.

биде с одним отверстием

Биде в комплекте с крепежом для пристенной установки.

унитаз с универсальным сливом

Унитаз с универсальным сливом, в комплекте с сиденьем с быстродействующим механизмом главного опускания, сливным коленом и крепежом. Пристенная установка. Может комбинироваться со смывными бачками серии Monolith. Полезный слив 4,5 литра.



350x480



350x480

YXC9 YXBY    4,5 lt

FUSION 48

+ MONOLITH

cassetta MONOLITH

Cassetta esterna in ceramica per installazione con vasi a filo muro. Meccanismo interno Geberit, doppio scarico 3/6 litri. Entrata acqua posteriore o laterale. Possibilità di installazione con scarico a terra variabile da 10 a 23 cm, oppure a parete.

chasse d'eau MONOLITH

Chasse d'eau extérieure en céramique pour installation avec cuvette au ras du mur. Mécanisme Geberit avec double touche avec possibilité de réglage à 3 ou 6 litres. Arrivée d'eau arrière ou latérale. Possibilité d'installation avec vidange au sol allant de 10 à 23 cm, ou bien murale.

MONOLITH Cistern

Ceramic cistern to be used with back-to-wall WCs. Geberit 3/6 litre inner mechanism with dual flush. Rear or side water inlet system Wall or floor outlet. The floor outlet can vary from 10 to 23 cm.

cisterna MONOLITH

Cisterna externa de cerámica para instalación de inodoros contra la pared. Mecanismo interno Geberit, doble descarga 3/6 litros. Entrada de agua posterior o lateral. Posibilidad de instalación con descarga de tierra variable de 10 a 23 cm, o bien, de pared.

MONOLITH Kasten

Vorwand Kasten in Keramik zur Wandmontage. Innen Mechanismus Geberit, Doppelspülung 3/6 l. Wassereingang rückwärtig oder seitlich. Montagemöglichkeit mit senkrechtem oder waagrechtem Abgang, senkrechter Abgang variiert von 10 bis 23 cm.



Бачок MONOLITH

Смывной керамический бачок для наружного монтажа к пристенным унитазам. Внутренний механизм Geberit, двойной слив 3-6 литров. Задний или боковой подвод воды. Возможна установка с регулируемым сливом в пол от 10 до 23 см или в стену.



370x610x900



YOYN 
YOMK 
YXBY 



FUSION

ORINATOIO

orinatoio sospeso

Orinatoio sospeso completo di fissaggi, morsetto e raccordo. Sifone di scarico non incluso.

urinoir suspendu

Urinoir suspendu avec système de fixations, étrier et raccord. Siphon non compris.

wall hung urinal

Wall-hung urinal complete with fixing element, clamp and inlet pipe. Urinal trap not included

urinario suspendido

Urinario suspendido completo de sistema de fijación, abrazadera y racor. Sifón de descarga no incluido.

wand-Urinal

Wand-Urinal inklusive Halterung, Klemme und Anschluss. Ablaufsiphon nicht inbegriffen.

Подвесной писсуар

Подвесной писсуар в комплекте с крепежом, зажимом и фитингом. Сливной сифон не входит в комплект.



685x325



YXC3





FUSION

ORINATOIO

orinatoio sospeso con predisposizione coperchio

Orinatoio sospeso completo di fissaggi, morsetto e raccordo. Coperchio in poliestere (YXCR) e sifone di scarico (YXF1) non inclusi.

orinatoio sospeso con fotocellula

Orinatoio sospeso con fotocellula "all in one" a batteria (YXC1) o a corrente elettrica (YXEW). Completo di staffa, rubinetto e sifone di scarico.

urinoir suspendu avec possibilité d'abattant

Urinoir suspendu avec système de fixations, étrier et raccord. Abattant en polyester (YXCR) et siphon (YXF1) non compris.

urinoir suspendu avec photocellule

Urinoir suspendu avec photocellule "all in one" (tout en un) à pile (YXC1) ou sur secteur (YXEW). Livré avec étrier, robinet et siphon de vidange.

wall-hung urinal to which a cover can be fitted.

Wall-hung urinal complete with fixing elements, clamp and inlet pipe. Polyester cover (YXCR) and urinal trap (YXF1) not included.

wall hung urinal with photocell

Wall hung urinal with "all in one" with battery-operated (YXC1) or electric photocell (YXEW). Complete with bracket, tap and urinal trap.

urinario suspendido – puede llevar tapa

Urinario suspendido completo de sistema de fijación, abrazadera y racor. Tapa de poliéster (YXCR) y sifón de descarga (YXF1) no incluidos.

urinario suspendido con fotocélula

Urinario suspendido con fotocélula "all in one", a batería (YXC1) o corriente eléctrica (YXEW). Completo de estribo, grifo y sifón de descarga.

wand-Urinal mit Deckelvorrichtung

Wand-Urinal inklusive Halterung, Klemme und Anschluss. Deckel in Polyester (YXCR) und Ablaufsiphon (YXF1) nicht inbegriffen.

wand-Urinal mit Fotozelle

Wand-Urinal mit Fotozelle "all in one" batterie- (YXC1) oder strombetrieben (YXEW). Inklusive Halterung, Armatur und Ablaufsiphon.

подвесной писсуар с отверстиями под крышку

Подвесной писсуар в комплекте с крепежом, зажимом и фитингом. Пластиковая крышка (YXCR) и сливной сифон не входят (YXF1) в комплект.

подвесной писсуар с фотодатчиком

Подвесной писсуар с фотодатчиком "all in one", работающий от батареи или (YXC1) от электрической сети (YXEW). В комплекте кронштейн, кран и сливной сифон.



685x325



685x325



YXE1

YXC1
YXEW



MEZZALUNA

EMILY



AREA
DESIGN NILO GIOACCHINI



AREA



AREA 110x35

Lavabo 110x35 cm sospeso a muro.
Installabile anche su mobile. Integrabile
con ripiani in ceramica, accessori
portasciugamani e sifone estetico.

110x35 cm wall-hung washbasin. Can also
be mounted on a custom-made custom-made
furniture. Can be combined with ceramic
shelves, towel holder and design siphon.

Waschbecken 110x35 cm wandhängend.
Zur Montage auch auf Badmöbeln. Ergänztbar
mit Keramikböden, Handtuchhaltern und
ästhetischem Siphon.

Lavabo 110x35 cm suspendu au mur.
Installable aussi avec bord de vasque apparent
sur meuble. Intégrable dans un plan de toilette
en céramique équipé de porte-serviettes et de
siphon esthétique.

Lavabo de 110x35 cm suspendido en la pared.
Se puede instalar también sobre un mueble.
Integrable con estantes de cerámica, con
portatoalla y sifón estético.

Подвесной настенный умывальник 110x35
см. Может также устанавливаться.
Комбинируются с керамическими полками,
вешалками для полотенец и сифоном в
эстетическом исполнении.

installazione
installation

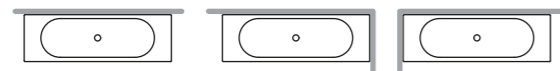

sospeso
wall hung

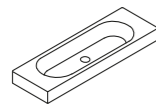

su mobile
on a custom-made furniture

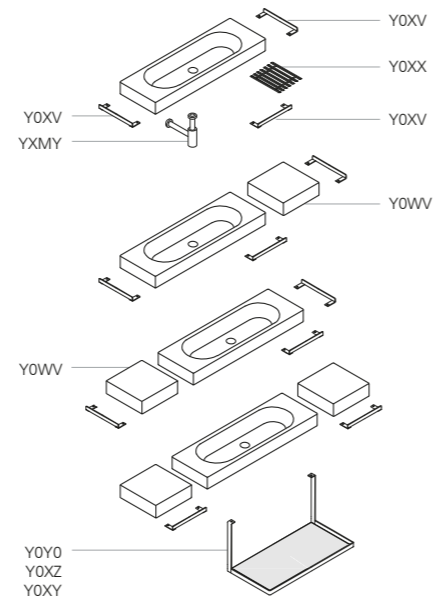
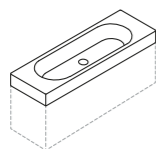

Y0W5
1100x350



AREA 106x45 - 81x45



Lavabi sospesi a muro, installabili anche su mobile. Integrabili con ripiani in ceramica, con portasciugamani e sifone estetico.

Wall-hung washbasins, can also be mounted on a custom-made furniture. Can be combined with ceramic shelves, towel holder and design siphon.

Waschbecken wandhängend, zur Montage auch auf Bademöbeln. Ergänztbar mit Keramikböden, Handtuchhaltern und ästhetischem Siphon.

Lavabos fixés au mur, installables aussi sur meuble. Intégrables dans un plan de toilette en céramique équipé de porte-serviettes et de siphon esthétique.

Lavabos para instalar suspendidos en la pared o sobre un mueble. Integrables con estantes de cerámica, portatoalla y sifón estético.

Подвесные настенные умывальники, могут также устанавливаться на тумбу или в сочетании. Комбинируются с керамическими полками, вешалками для полотенец и сифоном в эстетическом исполнении.

installazione
installation

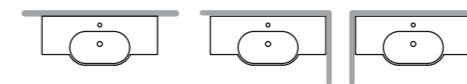

sospeso
wall hung

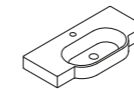
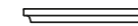

su mobile
on a custom-made furniture

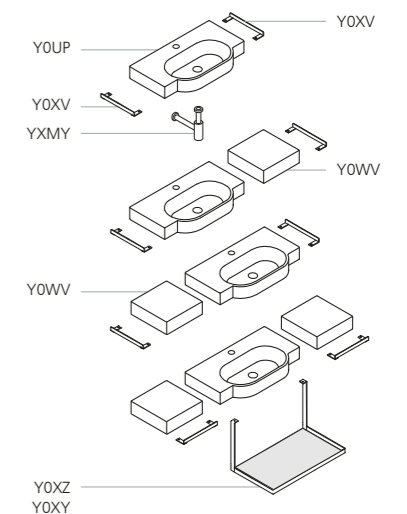
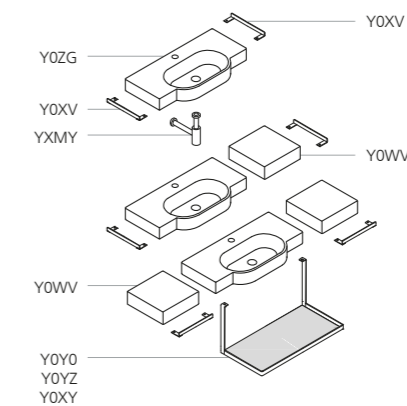
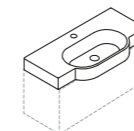

Y0ZG 
1060x450



Y0UP 
810x450



AREA 90x45

Lavabi 90x45 cm con bacino centrale oppure dx e sx con bacino asimmetrico, sospesi a muro. Installabili anche su mobile o con A-WOOD. Integrabili con ripiani in ceramica, con portasciugamani e sifone estetico.

Wall-hung with central basin or lh and rh washbasins, size 90x45 cm, with asymmetric basin. Can also be mounted on a custom-made furniture or with A-WOOD. Can be combined with ceramic shelves, towel holder and design siphon.

Waschbecken 90x45 cm mit Zentral Becken oder r. und l. mit asymmetrischen Becken, wandhängend. Zur Montage auch auf Bademöbeln oder mit A-WOOD. Ergänztbar mit Keramikböden, Handtuchhaltern und ästhetischem Siphon.

Lavabos 90x45 cm avec vasque centrale ou lavabos droit /gauche avec vasque asymétrique fixés au mur. Installables sur meuble ou avec A-WOOD. Intégrables dans un plan de toilette en céramique équipé de porte-serviettes et de siphon esthétique.

Lavabos de 90x45 cm con jofaina central o der. e izq., con jofaina asimétrica suspendida en la pared. Se pueden instalar también sobre un mueble o con A-WOOD. Integrables con estantes de cerámica, con portatoalla y sifón estético.

Настенные умывальники 90x45 см с центрального бассейна или правосторонние и левосторонние с асимметричной чашей. Могут также устанавливаться на тумбу или в сочетании с тумбой A-WOOD. Комбинируются с керамическими полками, вешалками для полотенец и сифоном в эстетическом исполнении.

installazione installation

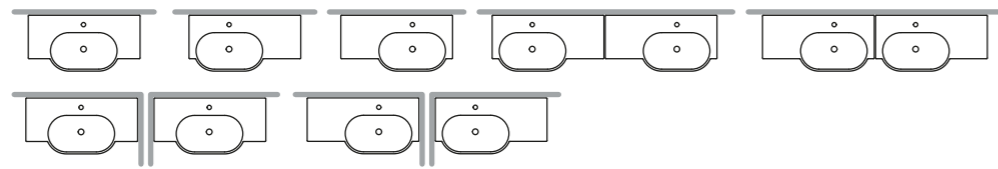

sospeso wall hung



su mobile on a custom-made furniture

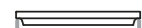

su A-WOOD on A-WOOD

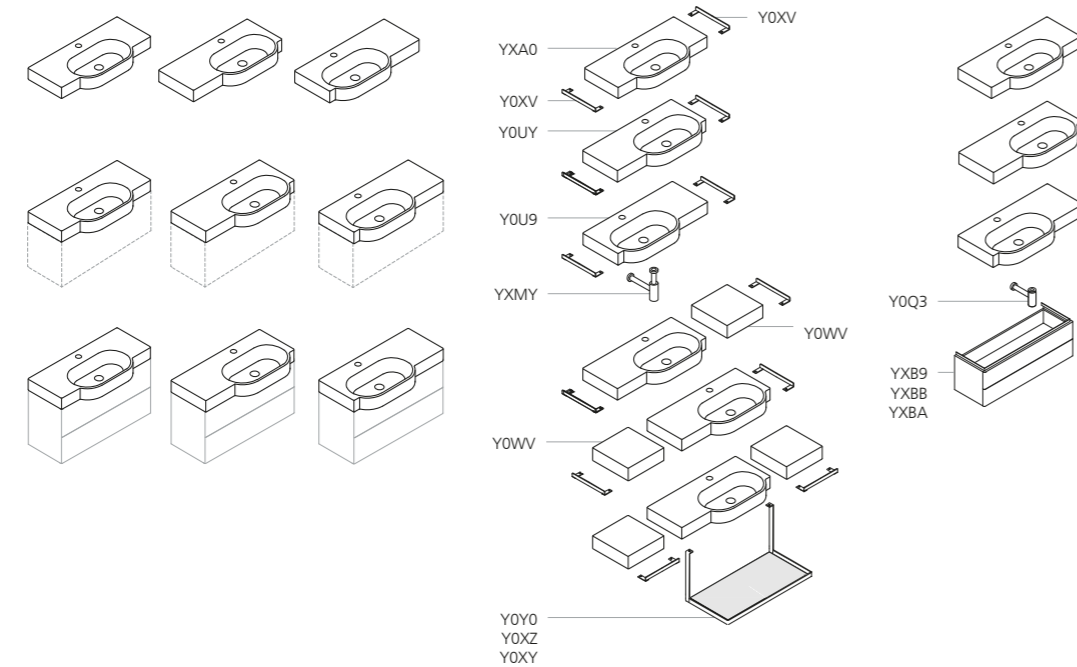

YXA0
900x450

Y0UY
900x450 dx-rh

Y0U9
900x450 sx-lh



AREA 90x50



Lavabi 90x50 cm dx e sx con bacino asimmetrico ed inclinato, sospesi a muro. Installabili anche su mobile o con A-WOOD. Integrabili con ripiani in ceramica, con portasciugamani e sifone estetico.

Wall-hung lh and rh washbasins, size 90x50 cm, with asymmetric basin. Can also be mounted on a custom-made furniture or with A-WOOD. Can be combined with ceramic shelves, towel holder and design siphon.

Waschbecken 90x50 cm r. und l. mit asymmetrischen Becken, wandhängend. Zur Montage auch auf Bademöbeln oder mit A-WOOD. Ergänztbar mit Keramikböden, Handtuchhaltern und ästhetischem Siphon.

Lavabos 90x50 cm droit et gauche avec vasque asymétrique fixés au mur. Installables sur meuble ou avec A-WOOD. Intégrables dans un plan de toilette en céramique équipé de porteserviettes et de siphon esthétique.

Lavabos de 90x50 cm der. e izq., con jofaina asimétrica suspendida en la pared. Se pueden instalar también sobre un mueble o con A-WOOD. Integrables con estantes de cerámica, con portatoalla y sifón estético.

Настенные умывальники 90x50 см правосторонние и левосторонние с асимметричной чашей. Могут также устанавливаться на тумбу или в сочетании с тумбой А-WOOD. Комбинируются с керамическими полками, вешалками для полотенец и сифоном в эстетическом исполнении.

installazione
installation

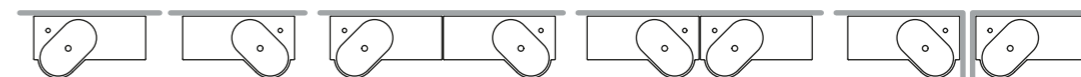

sospeso
wall hung



su mobile
on a custom-made furniture

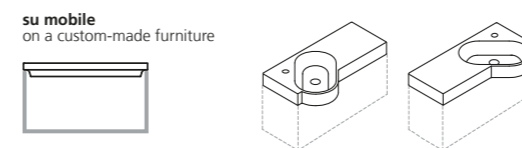

su A-WOOD
on A-WOOD

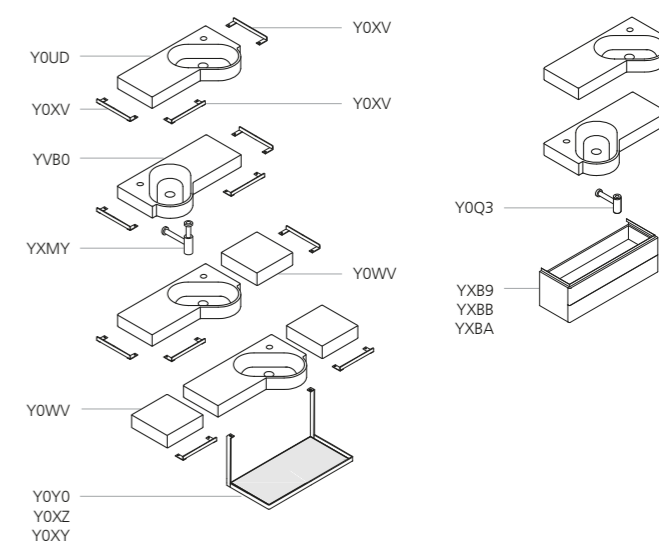
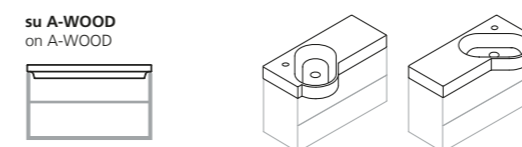

Y0UD 
900x500 dx-rh



YVBO 
900x500 sx-lh



AREA 90x35

Lavabo 90x35 cm sospeso a muro. Installabile anche su mobile o con A-WOOD, oppure in appoggio su piano. Integrabile con ripiani in ceramica, con portasciugamani e sifone estetico.

90x35 cm wall-hung washbasin. Can also be mounted on a custom-made furniture or with A-WOOD or surface-mounted. Can be combined with ceramic shelves, towel holder and design siphon.

Waschbecken 90x35 cm wandhängend. Zur Montage auch auf Bademöbeln oder mit A-WOOD, oder aufliegend. Ergänzierbar mit Keramikböden, Handtuchhaltern und ästhetischem Siphon.

Lavabo 90x35 cm suspendu au mur. Installable sur meuble ou avec A-WOOD, ou bien à bord de vasque apparent sur plan de toilette. Intégrable dans un plan de toilette en céramique équipé de porte-serviettes et de siphon esthétique.

Lavabo de 90x35 cm suspendido en la pared. Instalable también sobre mueble o con A-WOOD, así como apoyado sobre una encimera. Integrable con estantes de cerámica, con portatoalla y sifón estético.

Подвесной настенный умывальник 90x35 см. Может также устанавливаться на тумбу, в сочетании с тумбой A-WOOD или на полку. Комбинируются с керамическими полками, вешалками для полотенец и сифоном в эстетическом исполнении.

installazione installation

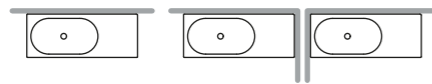

sospeso wall hung

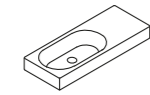

in appoggio surface mounted

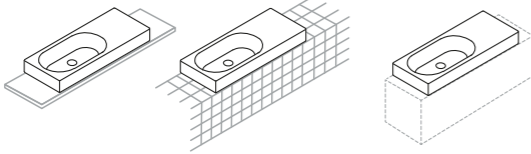

su mobile on a custom-made furniture

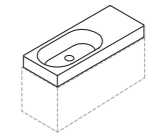
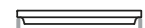

su A-WOOD on A-WOOD

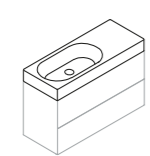

YOU E

YXE Q

YXDL

900x350

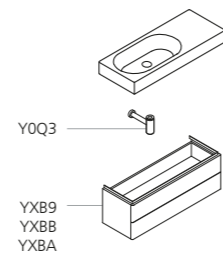
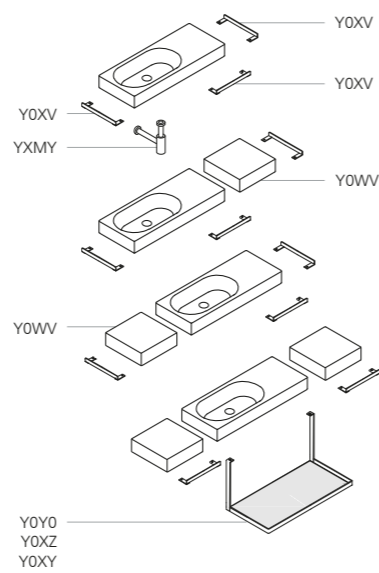



AREA 70x35

Lavabo 70x35 cm sospeso a muro. Installabile anche su mobile. Integrabile con ripiani in ceramica, accessori portasciugamani e sifone estetico.

70x35 cm wall-hung washbasin. Can also be mounted on a custom-made furniture. Can be combined with ceramic shelves, towel holder and design siphon.

Waschbecken 70x35 cm wandhängend. Zur Montage auch auf Bademöbeln. Ergänztbar mit Keramikböden, Handtuchhaltern und ästhetischem Siphon.

Lavabo 70x35 cm suspendu au mur. Installable aussi avec bord de vasque apparent sur meuble. Intégrable dans un plan de toilette en céramique équipé de porte-serviettes et de siphon esthétique.

Lavabo de 70x35 cm suspendido en la pared. Se puede instalar también sobre un mueble. Integrable con estantes de cerámica, con portatoalla y sifón estético.

Подвесной настенный умывальник 70x35 см. Может также устанавливаться. Комбинируются с керамическими полками, вешалками для полотенец и сифоном в эстетическом исполнении.

installazione
installation



sospeso
wall hung

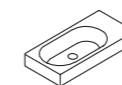

su mobile
on a custom-made furniture

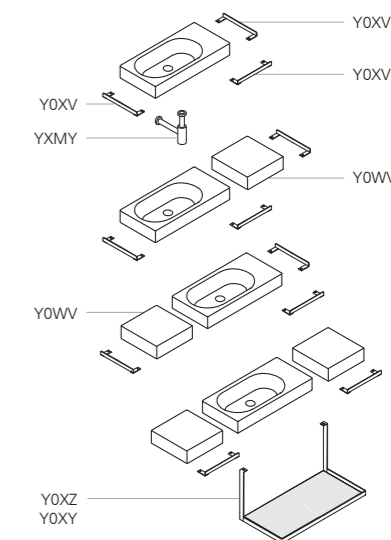
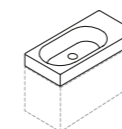

Y0W9

YXDK

700x354



AREA 60x45

Lavabo 60x45 cm sospeso a muro.
Integrabile con semicolonna in ceramica o con sifone estetico.

Lavabo 60x45 cm suspendu au mur. Intégrable avec une demi-colonne en céramique ou avec siphon esthétique.

60x45 cm wall-hung washbasin.
Can be combined with ceramic siphon cover or design siphon.

Lavabo 60x45 cm suspendido en la pared. Intégrable con semicolumna de cerámica o sifón estético.

Waschbecken 60x45 cm wandhängend.
Ergänzbar mit Halbsäule aus Keramik oder ästhetischem Siphon.

60x45 cm washbasin placeable hanging, with aesthetic siphon or with ceramics siphon cover.

installazione
installation

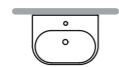

sospeso
wall hung

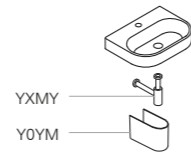
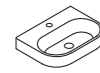
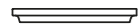

YOUH 
600x450



AREA 47x47



Lavabi 47x47 cm dx e sx sospesi a muro.
Integrabili con ripiani in ceramica, accessori
portasciugamani e sifone estetico.

Wall-hung lh and rh washbasin, size 47x47 cm.
Can be combined with ceramic shelves, towel
holder and design siphon.

Waschbecken 47x47 cm r. und l.
wandhängend. Ergänzung mit Keramikböden,
Handtuchhaltern und ästhetischem Siphon.

Lavabos 47x47 cm droit et gauche fixés au
mur. Intégrables dans un plan de toilette en
céramique équipé de porte-serviettes et de
siphon esthétique.

Lavabos de 47x47 cm der. e izq., suspendidos
en la pared. Integrabiles con estantes de
cerámica, portatoalla y sifón estético.

Подвесные настенные умывальники 47x47
см правосторонние и левосторонние.
Комбинируются с керамическими полками,
вешалками для полотенец и сифоном в
эстетическом исполнении.

installazione
installation

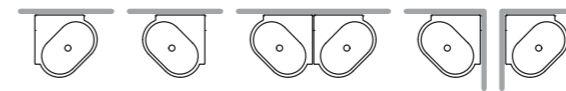

sospeso
wall hung

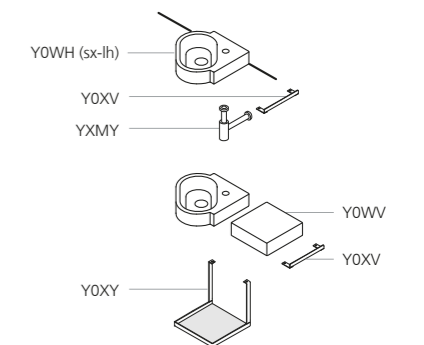
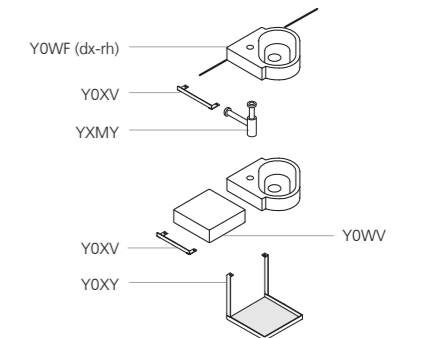
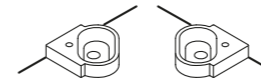

YOWF 
470x470 dx-rh



YOWH 
470x470 sx-lh



AREA 100x35

Lavabo 100x35 cm da installare in appoggio su piano o su base SLIDING WOOD SYSTEM. Integrabile con accessori e sifone estetico.

Lavabo 100x35 cm à installer avec bord de vasque apparent sur plan de toilette ou avec SLIDING WOOD SYSTEM. Intégrable avec accessoires et de siphon esthétique.

100x35 cm washbasin. Surface-mounted installation or SLIDING WOOD SYSTEM sink base unit. Can be combined with accessories and design siphon.

Lavabo de 100x35 cm a instalar sobre una encimera o con SLIDING WOOD SYSTEM. Integrable con accesorios y sifón estético.

Waschbecken 100x35 cm zur Montageauflage auf Ebene oder mit SLIDING WOOD SYSTEM. Ergänztbar mit Zubehör und ästhetischem Siphon.

Накладной умывальник 100x35 см устанавливается на полку или на SLIDING WOOD SYSTEM. Комбинируется с аксессуарами и сифоном в эстетическом исполнении.

installazione
installation



in appoggio
surface mounted

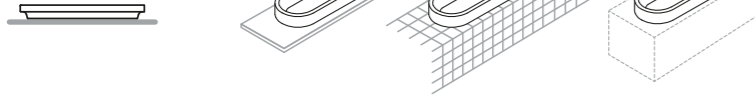

su base lavabo SLIDING WOOD SYSTEM
on SLIDING WOOD SYSTEM sink base unit

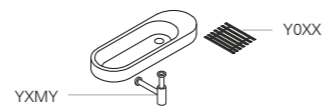

Y0W1 
1000x352





AREA 80x35

Lavabo 80x35 cm da installare in appoggio su piano o su base SLIDING WOOD SYSTEM. Senza troppopieno. Integrabile con accessori e sifone estetico.

Lavabo 80x35 cm à installer avec bord de vasque apparent sur plan de toilette ou avec SLIDING WOOD SYSTEM. Sans trop-plein. Intégrable avec accessoires et de siphon esthétique.

80x35 cm washbasin. Surface-mounted installation or SLIDING WOOD SYSTEM sink base unit. Without over-flow. Can be combined with accessories and design siphon.

Lavabo de 80x35 cm a instalar sobre una encimera o con SLIDING WOOD SYSTEM. Sin rebosadero. Integrable con accesorios y sifón estético.

Waschbecken 80x35 cm zur Montageauflage auf Ebene oder mit SLIDING WOOD SYSTEM. Ohne Überlauf. Ergänzung mit Zubehör und ästhetischem Siphon.

Накладной умывальник 80x35 см устанавливается на полку или на SLIDING WOOD SYSTEM. Без перелива. Комбинируется с аксессуарами и сифоном в эстетическом исполнении.

installazione
installation



in appoggio
surface mounted

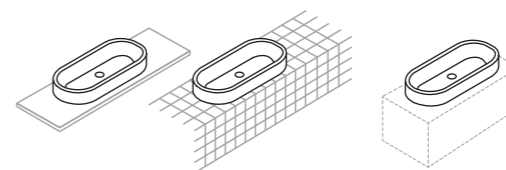

su base lavabo SLIDING WOOD SYSTEM
on SLIDING WOOD SYSTEM sink base unit



YOUF 
800x350



AREA 35x35

Ripiano in ceramica 35x35 cm sospeso a muro. Con o senza sistema easywarm® preinstallato. Può essere installato singolarmente oppure abbinato a tutti i lavabi Area di profondità 35 cm. Integrabile con accessori portasciugamani.

Étagère en céramique 35x35 cm fixée au mur. Avec ou sans système easywarm® préinstallé. Installable individuellement ou bien associée à tous les lavabos. Espace de profondeur 35 cm. Intégrables avec porte-serviettes.

35x35 cm wall-hung ceramic shelf. With or without easywarm® system prefitted. Can be mounted singly or combined with all the Area washbasins with a depth of 35 cm. Can be combined with towel holder.

Estante de cerámica, de 35x35 cm, suspendido en la pared. Con o sin sistema easywarm® preinstalado. Puede ser instalado individualmente o bien, combinado con todos los lavabos Area, con profundidad de 35 cm. Integrable con portatoalla.

Keramikboden 35x35 cm wandhängend. Mit oder ohne vorinstalliertem easywarm® System. Kann einzeln oder in Kombination mit sämtlichen Waschbecken Area der Tiefe von 35 cm montiert werden. Ergänztbar mit Handtuchhaltern.

Подвесная настенная полка из керамики 35x35 см. С встроенной системой обогрева easywarm® или без нее. Может устанавливаться отдельно или в сочетании со всеми умывальниками серии Area глубиной 35 см. Комбинируется с вешалками для полотенец.

installazione
installation

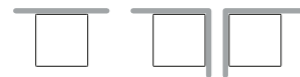

sospeso
wall hung

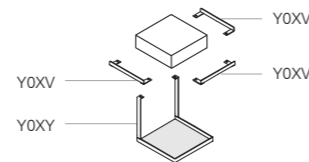
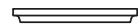

Y0Z0 easywarm®
Y0WV
350x350





A-WOOD

Mobile contenitore 88x35x50h a due cassetti che integra l'offerta dei lavabi del sistema AREA. A-Wood è abbinabile a tutti i lavabi Area da 90 cm. Area 90x35, 90x45, 90x45 destro, 90x45 sinistro, 90x50 destro, 90x50 sinistro. Disponibile in tre finiture: Bianco Lucido, Larice Moro e Betulla Naturale. Sifone speciale incluso.

Meuble de rangement de 88x35x50h à deux tiroirs intégrant la proposition des lavabos du système AREA. A-Wood peut être associé à tous les lavabos Area de 90 cm, Area 90x35, 90x45, 90x45 droit, 90x45 gauche, 90x50 droit, 90x50 gauche. Existe en trois finitions : Blanc Brillant, Mèlèze Foncé et Bouleau Naturel. Siphon spécial compris.

88x35x50h two-drawer unit that completes the range of AREA system washbasins. A-Wood can be combined with all 90 cm Area washbasins. Area 90x35, 90x45, 90x45 right-hand, 90x45 left-hand. Available in three finishes: Gloss White, Dark Larchwood and Natural Birchwood. Special siphon included.

Mueble contenedor, de 88x35x50h, con dos cajones que integra la oferta de los lavabos del sistema AREA. A-Wood se puede combinar con todos los lavabos Area de 90 cm. Area 90x35, 90x45, 90x45 derecho, 90x45 izquierdo, 90x50 derecho, 90x50 izquierdo. Disponible en tres acabados: Blanco Brillante, Alerce Moro y Abedul Natural. Sifón especial incluido.

Bademöbel 88x35x50h mit zwei Schubläden, zur Vervollständigung des Angebotes Waschbecken-System AREA. A-Wood lässt sich mit allen Waschbecken Area 90 cm kombinieren. Area 90x35, 90x45, 90x45 rechts, 90x45 links, 90x50 rechts, 90x50 links. Erhältlich in drei Ausfertigungen: Weiss glanz, Lärche dunkel und Birke naturell. Spezieller Siphon inklusive.

Тумба 88x35x50h с двумя ящиками дополняет ассортимент умывальников серии AREA. A-Wood комбинируется со всеми умывальниками серии Area размером 90 см. Умывальник Area 90x35, 90x45, 90x45 правосторонний, 90x45 левосторонний, 90x50 правосторонний, 90x50 левосторонний. Три типа отделки тумбы: Bianco Lucido (белый блестящий), Larice Moro (темная лиственница) и Betulla Naturale (светлая береза). Специальный сифон входит в комплект.

YXB9
880x350x500



Bianco Lucido Gloss White Weiss glanz
Blanc Brillant Blanco Brillante Bianco Lucido

YXBB
880x350x500



Betulla Naturale Light Birchwood Birke naturell
Bouleau Naturel Abedul Natural Betulla Naturale

YXBA
880x350x500



Larice Moro Dark Larchwood Lärche dunkel
Mèlèze Foncé Alerce Moro Larice Moro





AREA MEZZALUNA 90x35 - 70x35

Lavabo 70x35 / 90x35 cm sospeso a muro.
Installabile anche su mobile.

70x35 / 90x35 cm wall-hung washbasin. Can
also be mounted on a custom made furniture.

Waschbecken 70x35 / 90x35 cm
wandhängend. Zur Montage auch auf
Bademöbeln

Lavabo 70x35 / 90x35 cm suspendu au mur.
Installable aussi avec bord de vasque apparent
sur meuble.

Lavabo de 70x35 / 90x35 cm suspendido en
la pared. Se puede instalar también sobre un
mueble.

Подвесной настенный умывальник 70x35 /
90x35 см. Может также устанавливаться.

installazione
installation



sospeso
wall hung

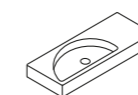

su mobile
on a custom-made furniture

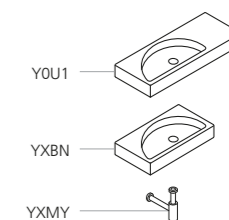
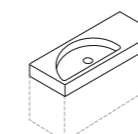

YU01 
900x350



YXBN 
700x350



AREA EMILY 106x50 - 81x50

Lavabo 81x50 / 106x50 cm sospeso a muro.
Installabile anche su mobile.

81x50 / 106x50 cm wall-hung washbasin.
Can also be mounted on a custom made
furniture.

Waschbecken 81x50 / 106x50 cm
wandhängend. Zur Montage auch auf
Bademöbeln.

Lavabo 81x50 / 106x50 cm suspendu au mur.
Installable aussi avec bord de vasque apparent
sur meuble.

Lavabo de 81x50 / 106x50 cm suspendido en
la pared. Se puede instalar también sobre un
mueble.

Подвесной настенный умывальник 81x50 /
106x50 см. Может также устанавливаться.

installazione
installation

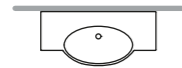

sospeso
wall hung

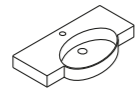

su mobile
on a custom-made furniture

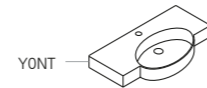
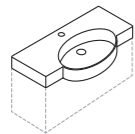

YONT

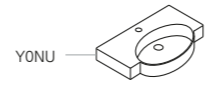

YONU



YXMY

YONT 
1060x500



YONU 
810x500





HAPPY HOUR + LAVABI D'APPOGGIO

SURFACE-MOUNTED WASHBASINS AUFSAZGWASCHBECKEN
MODÈLES DE LAVABOS À BORD DE VASQUE APPARENT
LAVABOS DE APOYO НАКЛАДНЫЕ УМЫВАЛЬНИКИ

HAPPY HOUR 07:00

Lavabo da 44 cm da installare in appoggio su piano o su base SLIDING WOOD SYSTEM. Senza troppopieno.

44 cm surface-mounted washbasin. Can be installed on SLIDING WOOD SYSTEM base unit. No overflow.

Waschbecken 44 cm zur Montage aufliegend, oder auf SLIDING WOOD SYSTEM. Ohne Überlauf.

Lavabo 44 cm à installer sur plan de toilette ou sur base SLIDING WOOD SYSTEM. Sans trop-plein.

Lavabo de 44 cm a instalar sobre una encimera o bien SLIDING WOOD SYSTEM. Sin rebosadero.

Накладной умывальник 44 см устанавливается на полку или на столешницу SLIDING WOOD SYSTEM. Без перелива

installazione
installation

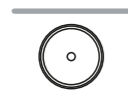

in appoggio
surface mounted

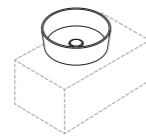
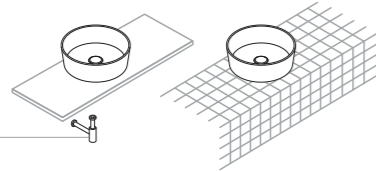

YXMY

su base lavabo SLIDING WOOD SYSTEM
on SLIDING WOOD SYSTEM sink base unit

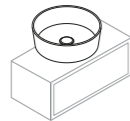

YXSK 
440x440





HAPPY HOUR 07:15

INCASSO SOTTOPIANO UNDERCOUNTER WASHBASIN UNTERBAUWASCHTISCH SOUS
PLAN BAJO ENCIMERA ВСТРАИВАЕМАЯ ПОД СТОЛЕШНИЦУ

lavabo 44 cm ad incasso. Installazione sotto il piano del mobile. Senza troppopieno.

44 cm countertop washbasin. To be installed under the vanity units. Without overflow.

Einbauwashtisch 44 cm. Montage unterm Möbelstück. Ohne Überlauf.

Vasque 44 cm à encastrer sous plan de toilette. Sans trop-plein.

lavabo de encastre 44 cm. Para instalar bajo encimera del mueble. Sin rebosadero.

Встроенный умывальник 44 см. установка под мебельную столешницу; без перелива.

installazione
installation

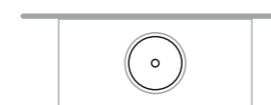

incasso sottopiano
built under

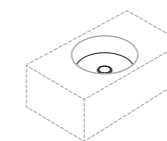
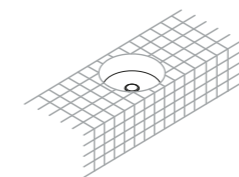

YXSP 
440x440



HAPPY HOUR 09:00

Lavabo da 48 cm sospeso a muro, completo di fissaggi. Può essere installato in appoggio su piano.

Lavabo de 48 cm suspendu au mur, livré avec kit de fixation. Installable aussi avec bord de vasque apparent sur plan de toilette.

Wall-hung 48 cm washbasin, complete with fixing elements. Can also be surface-mounted.

Lavabo de 48 cm suspendido en la pared, completo de sistema de fijación. También puede ser instalado sobre una encimera, o bien.

Wand-Waschbecken 48 cm, inklusive Halterungen. Auch zur Montage aufliegend.

Подвесной настенный умывальник 48 см в комплекте с крепежом. Может также устанавливаться на полку.

installazione
installation

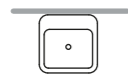

sospeso
wall hung



YXMY



in appoggio
surface mounted

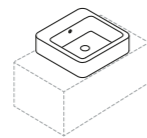
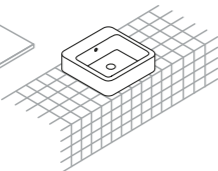
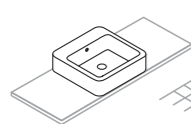

Y0M7 
480x480





HAPPY HOUR 09:30

Lavabo da 48 cm da installare in appoggio da semincasso su piano.

Lavabo de 48 cm, à installer à vasque semi-intégrée.

48 cm washbasin, to be installed for semi-built-in surface mounting.

Lavabo de 48 cm, puede ser instalado semi-empotrado sobre una encimera.

Halbeinbau-Waschbecken 48 cm, zur Montage aufliegend.

Умывальник 48 см, может иметь накладную и полувстроенную установку в полку.

installazione
installation



semincasso
half-built in

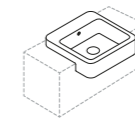
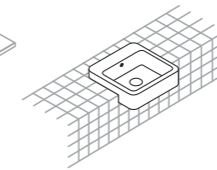
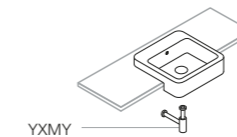

Y0M8 
480x480



HAPPY HOUR 10:00

Lavabo da 40 cm da installare in appoggio su piano o su base SLIDING WOOD SYSTEM. Senza troppopieno.

40 cm surface-mounted washbasin. Can be installed on SLIDING WOOD SYSTEM base unit. No overflow.

Waschbecken 40 cm zur Montage aufliegend oder mit SLIDING WOOD SYSTEM. Ohne Überlauf.

Lavabo de 40 cm à installer à bord de vasque apparent sur plan de toilette ou avec SLIDING WOOD SYSTEM. Sans trop-plein.

Lavabo de 40 cm a instalar sobre una encimera o con SLIDING WOOD SYSTEM. Sin rebosadero.

Накладной умывальник 40 см устанавливается на полку или на SLIDING WOOD SYSTEM. Без перелива.

installazione
installation



in appoggio
surface mounted

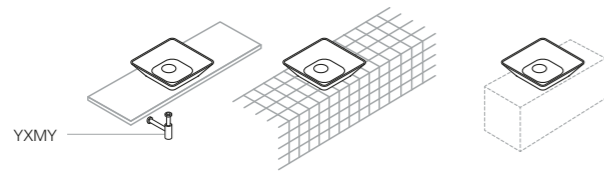

su base lavabo SLIDING WOOD SYSTEM
on SLIDING WOOD SYSTEM sink base unit

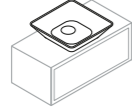
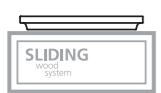

YQQR 
398x398





HAPPY HOUR 11:00

Lavabo da 50x38 cm da installare in appoggio su piano o su base SLIDING WOOD SYSTEM. Senza troppopieno.

50x38 cm surface-mounted washbasin. Can be installed on SLIDING WOOD SYSTEM base unit. No overflow.

Waschbecken 50x38 cm zur Montage aufliegend, oder auf SLIDING WOOD SYSTEM. Ohne Überlauf.

Lavabo 50x38 cm à installer sur plan de toilette ou sur base SLIDING WOOD SYSTEM. Sans trop-plein.

Lavabo de 50x38 cm a instalar sobre una encimera o bien SLIDING WOOD SYSTEM. Sin rebosadero.

Накладной умывальник 50x38 cm устанавливается на полку или на столешницу SLIDING WOOD SYSTEM. Без перелива

installazione
installation

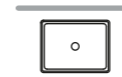

in appoggio
surface mounted

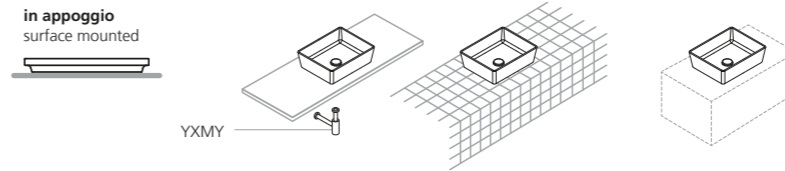

su base lavabo SLIDING WOOD SYSTEM
on SLIDING WOOD SYSTEM sink base unit



YXSL 
500x380



HAPPY HOUR 11:15

INCASSO SOTTOPIANO UNDERCOUNTER WASHBASIN UNTERBAUWASCHTISCH SOUS
PLAN BAJO ENCIMERA ВСТРАИВАЕМАЯ ПОД СТОЛЕШНИЦУ

lavabo 48x38 cm ad incasso. Installazione
sotto il piano del mobile. Senza
troppopieno.

48x38 cm countertop washbasin. To be
installed under the vanity units. Without
overflow.

Einbauwaschtisch 48x38 cm. Montage unterm
Möbelstück. Ohne Überlauf.

Vasque 48x38 cm à encastrer sous plan de
toilette. Sans trop-plein.

lavabo de encastre 48x38 cm. Para instalar bajo
encimera del mueble. Sin rebosadero.

Встроенный умывальник 48x38 см.
установка под мебельную столешницу;
без перелива.

installazione
installation

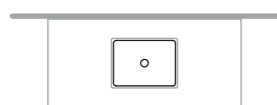

incasso sottopiano
built under

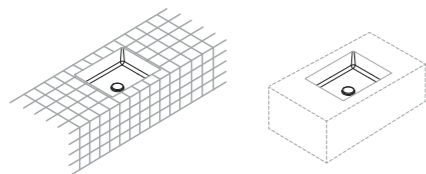

YXSQ 
500x380





HAPPY HOUR 17:00

Lavabo 55x40,5 cm da installare in appoggio su piano o su base SLIDING WOOD SYSTEM. Senza troppopieno.

55x40,5 cm surface-mounted washbasin. Can be installed on SLIDING WOOD SYSTEM base unit. No overflow.

Waschbecken 55x40,5 cm zur Montage aufliegend oder mit SLIDING WOOD SYSTEM. Ohne Überlauf.

Lavabo de 55x40,5 cm à installer à bord de vasque apparent sur plan de toilette ou avec SLIDING WOOD SYSTEM. Sans trop-plein.

Lavabo de 55x40,5 cm a instalar sobre una encimera o con SLIDING WOOD SYSTEM. Sin rebosadero.

Накладной умывальник 55x40,5 см устанавливается на полку или на SLIDING WOOD SYSTEM. Без перелива.

installazione
installation



in appoggio
surface mounted

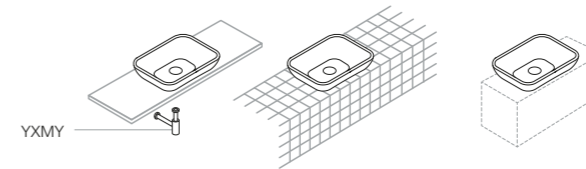

su base lavabo SLIDING WOOD SYSTEM
on SLIDING WOOD SYSTEM sink base unit

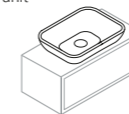

Y0QQ 
550x405



HAPPY HOUR 22:00

Lavabo 70x40 cm da installare in appoggio su piano su base SLIDING WOOD SYSTEM.

70x40 cm surface-mounted washbasin. Can be installed on SLIDING WOOD SYSTEM base unit.

Waschbecken 70x40 cm zur Montage aufliegend oder mit SLIDING WOOD SYSTEM.

Lavabo de 70x40 cm à installer à bord de vasque apparent sur plan de toilette ou avec SLIDING WOOD SYSTEM.

Lavabo de 70x40 cm a instalar sobre una encimera o con SLIDING WOOD SYSTEM.

Накладной умывальник 70x40 см устанавливается на полку или на SLIDING WOOD SYSTEM. Без перелива.

installazione
installation

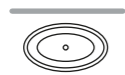

in appoggio
surface mounted

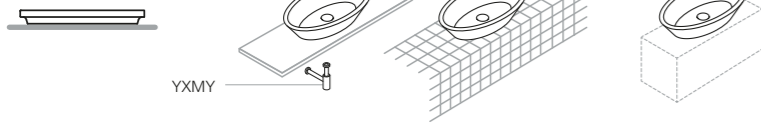

su base lavabo SLIDING WOOD SYSTEM
on SLIDING WOOD SYSTEM sink base unit



Y0M9 
700x400





HAPPY HOUR 02:00

Lavabo da 47,5 cm da installare in appoggio su piano o su base SLIDING WOOD SYSTEM.

Lavabo de 47,5 cm à installer avec bord de vasque apparent sur plan de toilette ou avec SLIDING WOOD SYSTEM.

47,5 cm surface-mounted washbasin. Can be installed on SLIDING WOOD SYSTEM base unit.

Lavabo de 47,5 cm a instalar sobre una encimera o con SLIDING WOOD SYSTEM.

Waschbecken 47,5 cm zur Montage aufliegend oder mit SLIDING WOOD SYSTEM.

Накладной умывальник 47,5 см устанавливается на полку или на SLIDING WOOD SYSTEM.

installazione
installation

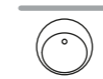

in appoggio
surface mounted

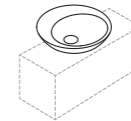
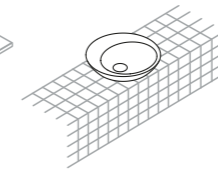
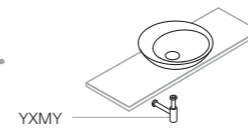

su base lavabo SLIDING WOOD SYSTEM
on SLIDING WOOD SYSTEM sink base unit

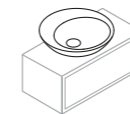

Y0M6

475x475



HAPPY HOUR 03:00

Lavabo da 47 cm da installare in appoggio su piano o su base SLIDING WOOD SYSTEM.

Lavabo 47 cm à installer sur plan de toilette ou sur base SLIDING WOOD SYSTEM.

47 cm surface-mounted washbasin. Can be installed on SLIDING WOOD SYSTEM base unit.

Lavabo de 47 cm a instalar sobre una encimera, o bien SLIDING WOOD SYSTEM.

Waschbecken 47cm zur Montage aufliegend, oder auf SLIDING WOOD SYSTEM.

Накладной умывальник 47 см устанавливается на полку или на столешницу SLIDING WOOD SYSTEM.

installazione
installation

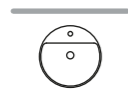

in appoggio
surface mounted

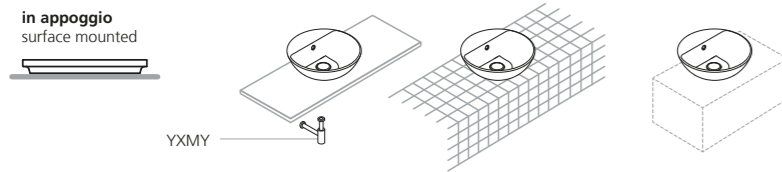

su base lavabo SLIDING WOOD SYSTEM
on SLIDING WOOD SYSTEM sink base unit



YXSJ 
470x470





AREA 80x35

Lavabo 80x35 cm da installare in appoggio su piano o su base SLIDING WOOD SYSTEM. Senza troppopieno. Integrabile con accessori e sifone estetico.

80x35 cm surface-mounted washbasin. Can be installed on SLIDING WOOD SYSTEM base unit. Without overflow. Can be combined with accessories and design siphon.

Waschbecken 80x35 cm zur Montageauflage auf Ebene oder mit SLIDING WOOD SYSTEM. Ohne Überlauf. Ergänzung mit Zubehör und ästhetischem Siphon.

Lavabo 80x35 cm à installer avec bord de vasque apparent sur plan de toilette ou avec SLIDING WOOD SYSTEM. Sans trop-plein. Intégrable avec accessoires et de siphon esthétique.

Lavabo de 80x35 cm a instalar sobre una encimera o con SLIDING WOOD SYSTEM. Sin rebosadero. Integrable con accesorios y sifón estético.

Накладной умывальник 80x35 см устанавливается на полку или на SLIDING WOOD SYSTEM. Без перелива. Комбинируется с аксессуарами и сифоном в эстетическом исполнении.

installazione
installation



in appoggio
surface mounted

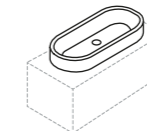
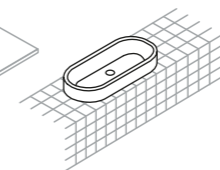

su base lavabo SLIDING WOOD SYSTEM
on SLIDING WOOD SYSTEM sink base unit

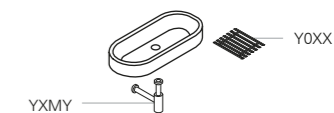

YOUF 
800x350



NIDO 75

Lavabo da 75 cm in appoggio. Può essere installato su piano o su base SLIDING WOOD SYSTEM ed è utilizzabile con rubinetteria a parete o sul piano d'appoggio. Senza troppopieno.

Lavabo de 75 cm à bord de vasque apparent. Installable sur plan de toilette ou avec SLIDING WOOD SYSTEM et utilisé avec robinetterie murale ou sur plan de toilette. Sans trop-plein.

75 cm surface-mounted washbasin. Can be installed on SLIDING WOOD SYSTEM base unit. Without overflow.

Lavabo de 75 cm a apoyar. Puede ser instalado sobre una encimera o con SLIDING WOOD SYSTEM utilizando grifería de pared o encimera. Sin rebosadero.

Waschbecken 75 cm aufliegend oder mit SLIDING WOOD SYSTEM. Zur Montage auf Oberfläche verwendbar mit Wand- oder Waschtischarmaturen. Ohne Überlauf.

Накладной умывальник 75 см. Может устанавливаться на полку или на SLIDING WOOD SYSTEM и используется с настенными или в столешнице кранами. Без перелива.

installazione
installation

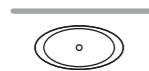

in appoggio
surface mounted

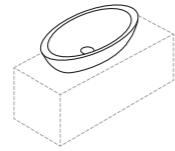
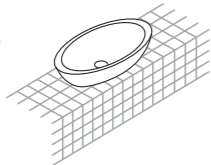
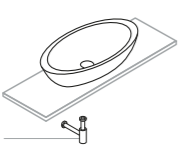

su base lavabo SLIDING WOOD SYSTEM
on SLIDING WOOD SYSTEM sink base unit

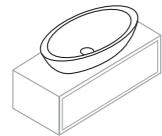

YOR2 
750x370





DAYTIME / DAYTIME EVO

DESIGN ANTONIO BULLO / NILO GIOACCHINI



DAYTIME 110

Lavabo da 110 cm a bacino unico sospeso a muro, completo di fissaggi. Installabile anche su mobile. Disponibile in tre versioni, senza fori, con 1 foro centrale oppure con 2 fori laterali rubinetteria. Integrabili con strutture portasciugamani in acciaio inox e sifone estetico.

Single 110 cm wall-hung washbasin, complete with fixing elements. Can be mounted on countertop. Available in three versions: without holes, with one central hole or with 2 side holes for the taps. Can be combined with stainless steel towel-holder frames and aesthetic trap.

Waschbecken Ausmaß 110 cm Einzelbecken wandhängend, inklusive Halterung. Zur Montage auch auf Bademöbeln. Erhältlich in drei Versionen, ohne Löcher, mit 1 zentralen Loch oder mit 2 seitlichen Armaturenlöchern. Ergänztbar mit Handtuchhalterstrukturen in Edelstahl und ästhetischen Siphon.

Lavabo de 110 cm à vasque unique suspendu au mur, livré avec kit de fixation. Installable avec bord de vasque apparent sur meuble. Existe en trois versions sans trous, avec 1 trou central ou avec 2 trous latéraux pour la robinetterie. Intégrables avec des porte-serviettes en acier inox et avec siphon esthétique.

Lavabo de 110 cm, con jofaina única, suspendido en la pared, completo de sistema de fijación. Se puede instalar también sobre un mueble. Disponible en tres versiones, sin orificios, con 1 orificio central o bien, con 2 orificios laterales para la grifería. Integrables con estructuras portatoalla de acero inoxidable y sifón estético.

Подвесной настенный умывальник 110 см с одной чашей в комплекте с крепежом. Может также устанавливаться на тумбу. Три модели: без отверстий, с 1 центральным отверстием или с 2 боковыми отверстиями для комплекта кранов. Комбинируется с вешалкой для полотенец из нержавеющей стали.

installazione
installation

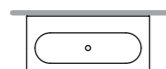

sospeso
wall hung

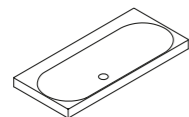

su mobile
on countertop

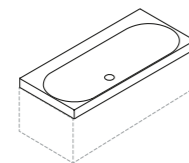
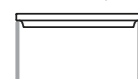

1105x500

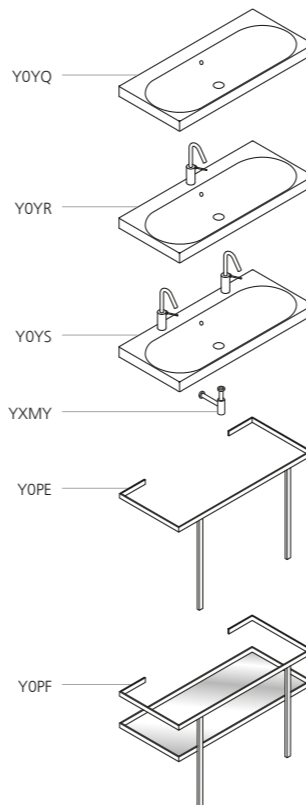
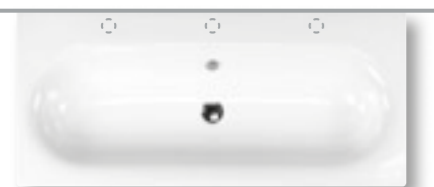

DAYTIME 86



Lavabi da 86 cm con bacino destro o sinistro, sospesi a muro, completi di fissaggi. Integrabili con semicolonna in ceramica oppure con strutture portaciugamani in acciaio inox e sifone estetico.

Dh or lh 86 cm wall-hung washbasins, complete with fixing elements. Can be combined with ceramic siphon cover or with stainless steel towel-holder frames and aesthetic trap.

Washbecken Ausmaß 86 cm mit rechts – oder linksseitigem Becken, wandhängend, inklusive Halterungen. Ergänztbar mit Halbsäule in Keramik oder mit Handtuchhalter-Strukturen in Edelstahl und ästhetischen Siphon.

Lavabos de 86 cm avec vasque à droite ou à gauche, fixés au mur, livrés avec kit de fixation. Intégrables avec demi-colonne en céramique ou bien avec des porte-serviettes en acier inox et avec siphon esthétique.

Lavabos de 86 cm con jofaina derecha o izquierda, suspendidos en la pared, completos de sistema de fijación. Integrables con semicolumna de cerámica o bien, con estructuras portatoalla de acero inoxidable y sifón estético.

Подвесные настенные умывальники 86 см с правой или левой чашей в комплекте с крепежом. Комбинируется с полупьедесталом из керамики или с вешалкой для полотенец из нержавеющей стали.

installazione
installation



sospeso
wall hung

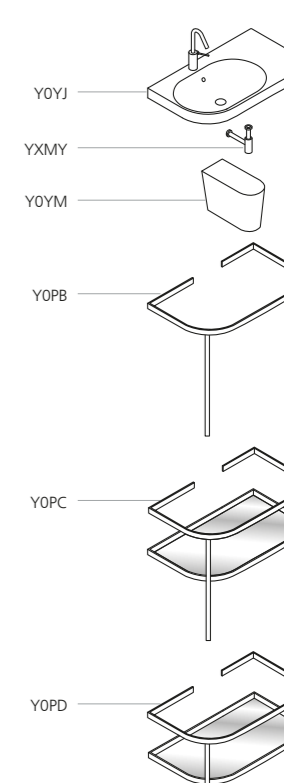
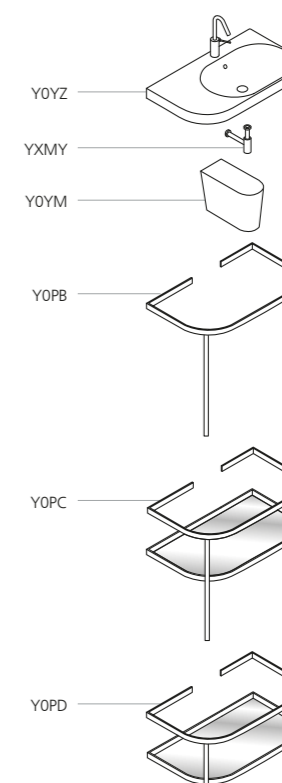
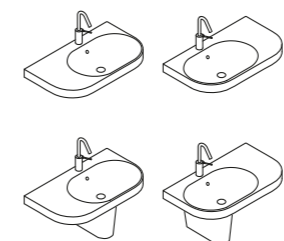

YOYZ

860x500 dx - rh



YOYJ

860x500 sx - lh

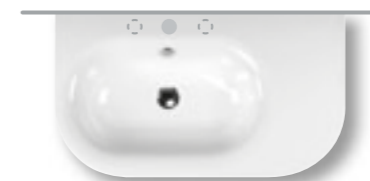

DAYTIME 70 - 62

Lavabi sospesi a muro, completi di fissaggi. Integrabili con semicolonna in ceramica, oppure con struttura portasciugamani in acciaio inox e sifone estetico.

Wall-hung washbasins, complete with fixing elements. Can be combined with ceramic siphon cover or with stainless steel towel-holder frames and aesthetic trap.

Waschbecken wandhängend, inklusive Halterungen. Ergänztbar mit Halbsäule in Keramik, oder mit Handtuchhalterstruktur in Edelstahl und ästhetischen Siphon.

Lavabos fixés au mur, livrés avec kit de fixation. Intégrables avec demi-colonne en céramique, ou bien avec porte-serviettes en acier inox et avec siphon esthétique.

Lavabos suspendidos en la pared, completos de sistema de fijación. Integrables con semicolumna de cerámica, o bien, con estructura portatoalla de acero inoxidable y sifón estético.

Подвесные настенные умывальники в комплекте с крепежом. Комбинируется с полупьедесталом из керамики или с вешалкой для полотенец из нержавеющей стали.

installazione
installation

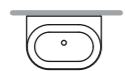

sospeso
wall hung

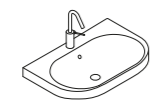

Y0YV



YXMY



Y0YM



Y0P8



Y0P9

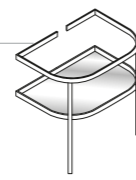

Y0PA



Y0YT

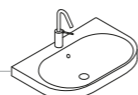

YXMY



Y0YM



Y0YV



700x500



Y0YT



620x500





DAYTIME 62

Lavabo da 62 cm da incasso soprapiano.
É utilizzabile con rubinetteria a parete o
sul piano d'appoggio.

Lavabo de 62 cm à bord de vasque apparent.
Il est utilisable avec une robinetterie murale ou
installée sur le plan de toilette.

Surface-mounted built-in washbasin, size 62
cm. Compatible with taps mounted on the wall
or on the surface.

Lavabo de 62 cm a empotrar sobre encimera.
Se puede utilizar con grifería de pared o
encimera.

Einbauwaschbecken 62 cm. Verwendbar mit
Wandarmaturen oder auf dem Becken.

Умывальник 62 см для встроенной
или накладной установки. Монтаж с
настенными или в столешнице кранами.

installazione
installation

incasso
built in

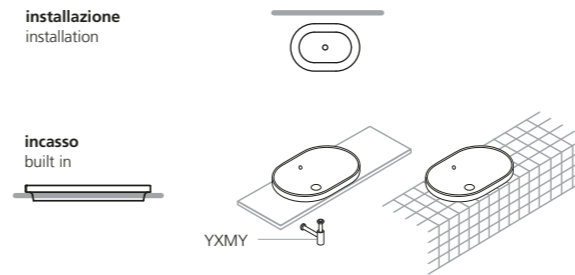

YOYU 

615x430



DAYTIME 55 - 45

Lavabi sospesi a muro, completi di fissaggi. Integrabili con semicolonna in ceramica o sifone estetico.

Lavabos fixés au mur, livrés avec kit de fixation. Intégrables avec demi-colonne en céramique et avec siphon esthétique.

Wall-hung washbasins, complete with fixing elements. Can be combined with ceramic siphon cover or aesthetic trap.

Lavabos suspendidos en la pared, completos de sistema de fijación. Integrables con semicolumna de cerámica y sifón estético.

Waschbecken wandhängend, inklusive Halterungen. Ergänztbar mit Halbsäule in Keramik und ästhetischen Siphon.

Подвесные настенные умывальники в комплекте с крепежом. Комбинируется с полупьедесталом из керамики.

installazione
installation

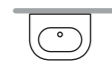

sospeso
wall hung

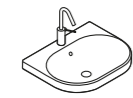

YXBL

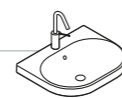

YXBM

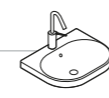

YXMY



YXMY



YXCQ



YXCQ



YXBL



550x450



YXBM



450x378





DAYTIME EVO

bidet monoforo filo muro

Bidet completo di fissaggi per installazione a filo muro.

vaso scarico universale filo muro con sedile

Vaso scarico universale completo di sedile, curva tecnica di scarico e fissaggio. Installazione a filo muro. Può essere abbinato alle cassette Monolith.

bidet à un trou ras du mur

Bidet avec kit de fixation pour installation au ras du mur.

cuvette vidange universelle ras du mur avec abattant

Cuvette vidange universelle avec abattant, tuyau coudé de vidange et fixation. Installation au ras du mur. Elle peut être associée aux chasses d'eau Monolith.

back-to-wall one hole bidet

Back-to-wall bidet, complete with fixing elements.

back to wall wc with universal outlet and with seat cover

WC with universal outlet, complete with seat cover, "s" trap convertor and fixing elements. Back-to-wall installation. Compatible with Monolith cisterns.

bidé de un orificio contra la pared

Bidé completo de sistema de fijación para instalación contra la pared.

inodoro con descarga universal contra la pared completo de asiento

Inodoro con descarga universal completo de asiento, curva técnica de descarga y sistema de fijación. Instalación contra la pared. Puede ser combinado con las cisternas Monolith.

Einlochbidet zur Wandmontage

Bidet inklusive Halterungen zur Wandmontage.

Wc mit Universal Abgang inklusive Sitz Zur Wandmontage

Tiefspüler mit Universal Abgang, komplett mit Sitz, technischer Ablauf-Kurve und Halterung. Zur Wandmontage. Kombinierbar mit WC-Kasten Monolith.

биде с одним отверстием

Биде в комплекте с крепежом для пристенной установки.

унитаз с универсальным сливом

Унитаз с универсальным сливом, в комплекте с сиденьем, сливным коленом и крепежом. Пристенная установка. Может комбинироваться со смывными бачками серии Monolith.



370x560



370x560



YQ35



YQ37
YQ36

DAYTIME EVO

vaso monoblocco con cassetta e sedile

Vaso monoblocco scarico universale per installazione a filo muro, completo di sedile, curva tecnica e fissaggi. Da integrare con cassetta Quadra in ceramica, entrata acqua laterale/alta e bassa.

cuvette monobloc avec chassis d'eau et abbattant

Cuvette monobloc à vidange universelle pour installation au ras du mur, avec abbattant, tuyau coudé et kit de fixations. À intégrer avec une chasse d'eau Quadra en céramique, arrivée d'eau latérale/en haut et en bas.

back-to-wall one-piece WC with cistern seat cover

Back-to-wall one-piece toilet bowl with universal outlet, complete with seat cover, "s" trap convertor and fixing elements. To be combined with Quadra ceramic cistern, water intake the side top/bottom.

inodoro monobloque con cisterna e asiento

Inodoro monobloque, con descarga universal para instalar contra la pared, completo de asiento, curva técnica y sistema de fijación. A integrar con cisterna Quadra de cerámica, entrada de agua lateral/alta y baja.

Kompaktes Klosett mit Spülkasten inklusive Sitz

Kompaktes Klosett mit Universal Abgang, inklusive Sitz, technischer Kurve und Halterung. Zur Ergänzung mit quadratischem WC Kasten in Keramik, Wassereingang hoch und niedrig-mittig.

моноблочный пристенный унитаз

Моноблочный унитаз с универсальной системой слива для пристенной установки, включает сиденье, сливное колено и крепеж. Должен быть дополнен смывным керамическим бачком Quadra, боковой/ верхний и нижний подвод воды.



370x660x815



- YXHS 
- YXHQ 
- YXGR 
- YXGV 
- YXGT 
- YXGS 





DAYTIME

bidet sospeso monoforo

Bidet sospeso da installare con staffa universale per sospesi.

vaso sospeso con sedile

Vaso sospeso completo di sedile. Installazione con staffa universale per sospesi.

bidet suspendu à un trou

Bidet suspendu à installer avec étrier universel pour éléments suspendus.

cuvette suspendue avec abbattant

Cuvette suspendue avec abbattant. Installation avec étrier universel pour éléments suspendus.

one-hole wall-hung bidet

Wall-hung bidet, mounted using universal bracket for wall-hung elements.

wall-hung WC with seat cover

Wall-hung WC with seat cover, mounted using universal bracket for wall-hung elements.

bidé suspendido con un orificio

Bidé suspendido a instalar con estribo universal para artefactos suspendidos.

inodoro suspendido completo de asiento

Inodoro suspendido completo de asiento. Instalación con estribo universal para artefactos suspendidos.

einlochbidet wandhängend

Wand-WC zur Montage mit universeller Wand-Halterung.

Hänge-Wc inklusive Sitz

Hänge-WC inklusive Sitz. Zur Montage mit universeller Wand-Halterung.

подвесное биде с одним отверстием

Подвесное биде устанавливается с универсальным кронштейном для подвесной сантехники.

подвесной унитаз

Подвесной унитаз в комплекте с сиденьем. Установка с универсальным кронштейном для подвесной сантехники.



370x560



Y0YP 



370x560



Y0YX 
Y0YY 

DAYTIME

bidet monoforo filo muro

Bidet completo di fissaggi per installazione a filo muro.

vaso scarico universale filo muro con sedile

Vaso scarico universale completo di sedile, curva tecnica di scarico e fissaggio. Installazione a filo muro. Può essere abbinato alle cassette Monolith.

bidet à un trou ras du mur.

Bidet avec kit de fixation pour installation au ras du mur.

cuvette vidange universelle ras du mur avec abattant

Cuvette vidange universelle avec abattant, tuyau coudé de vidange et fixation. Installation au ras du mur. Elle peut être associée aux chasses d'eau Monolith cisterns.

back to wall one hole bidet

Back-to-wall bidet, complete with fixing elements.

back to wall wc with universal outlet and with seat cover

WC with universal outlet, complete with seat cover, "s" trap convertor and fixing elements. Back-to-wall installation. Compatible with Monolith cisterns.

bidé de un orificio contra la pared

Bidé completo de sistema de fijación para instalación contra la pared.

inodoro con descarga universal contra la pared completo de asiento

Inodoro con descarga universal completo de asiento, curva técnica de descarga y sistema de fijación. Instalación contra la pared. Puede ser combinado con las cisternas Monolith.

einlochbidet zur Wandmontage

Bidet inklusive Halterungen zur Wandmontage.

Wc mit Universal Abgang inklusive Sitz zur Wandmontage

Tiefspüler mit Universal Abgang, komplett mit Sitz, technischer Ablauf-Kurve und Halterung. Zur Wandmontage. Kombinierbar mit WC-Kasten Monolith.

биде с одним отверстием

Биде в комплекте с крепежом для пристенной установки.

унитаз с универсальным сливом

Унитаз с универсальным сливом, в комплекте с сиденьем, сливным коленом и крепежом. Пристенная установка. Может комбинироваться со смывными бачками серии Monolith.



370x560



370x560



Y0Y1



Y0YK
Y0YW





DAYTIME / DAYTIME EVO

+ MONOLITH

Cassetta MONOLITH

Cassetta esterna in ceramica per installazione con vasi a filo muro. Meccanismo interno Geberit, doppio scarico 3/6 litri. Entrata acqua posteriore o laterale. Possibilità di installazione con scarico a terra variabile da 10 a 23 cm, oppure a parete.

MONOLITH Cistern

Ceramic cistern to be used with back-to-wall WCs. Geberit 3/6 litre inner mechanism with dual flush. Back or side water inlet system with Wall or floor outlet. The floor outlet can vary from 10 to 23 cm.

MONOLITH Kasten

Vorwand Kasten in Keramik zur Wandmontage. Innen Mechanismus Geberit, Doppelspülung 3/6 l. Wassereingang rückwärtig oder seitlich. Montagemöglichkeit mit senkrechtem oder waagerechtem Abgang, senkrechter Abgang variierbar von 10 bis 23 cm.

Chasse d'eau MONOLITH

Chasse d'eau extérieure en céramique pour installation avec cuvette au ras du mur. Mécanisme Geberit avec double touche avec possibilité de réglage à 3 ou 6 litres. Arrivée d'eau arrière ou latérale. Possibilité d'installation avec vidange au sol allant de 10 à 23 cm, ou bien murale.

Cisterna MONOLITH

Cisterna externa de cerámica para instalación de inodoros contra la pared. Mecanismo interno Geberit, doble descarga 3/6 litros. Entrada de agua posterior o lateral. Posibilidad de instalación con descarga de tierra variable de 10 a 23 cm, o bien, de pared.

бачок MONOLITH

Смывной керамический бачок для наружного монтажа к пристенным унитадам. Внутренний механизм Geberit, двойной слив 3-6 литров. Задний или боковой подвод воды. Возможна установка с регулируемым сливом в пол от 10 до 23 см или в стену.



370x690x900



370x690x900



- Y0MK
- Y0YN
- Y0YK
- Y0YW



- Y0MK
- Y0YN
- YQ37
- YQ36





NIDO

NIDO 68 - 62 - 56

Lavabi sospesi a muro. Integrabili con colonna o semicolonna. Installabili anche in appoggio su piano o su base SLIDING WOOD SYSTEM.

Wall-hung washbasins. Can be combined with full column or siphon cover. Can be installed surface-mounted on SLIDING WOOD SYSTEM base unit.

Wand-Waschbecken. Ergänzar mit Säule oder Halbsäule. Auch aufliegend oder mit SLIDING WOOD SYSTEM.

Lavabos fixés au mur. Intégrables colonne ou demi-colonne. Installables aussi avec bord de vasque apparent sur plan de toilette ou avec SLIDING WOOD SYSTEM.

Lavabos suspendidos en la pared. Integrables con columna o semicolumna. Se puede instalar también sobre una encimera o con SLIDING WOOD SYSTEM.

Подвесные настенные умывальники. Комбинируется с пьедесталом или полупьедесталом. Устанавливаются также на полку или на SLIDING WOOD SYSTEM.

installazione
installation

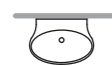

sospeso
wall hung



in appoggio
surface mounted

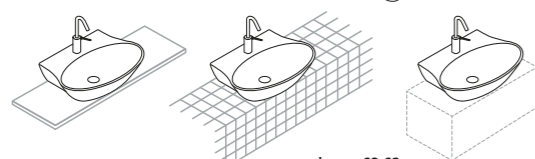

solo per 68-62
only for 68-62

su base lavabo SLIDING WOOD SYSTEM
on SLIDING WOOD SYSTEM sink base unit

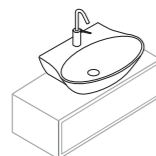

solo per 68-62
only for 68-62

YXEP 

Y0QX

680x480



YXEM 

Y0R4 

620x470



Y0TT 

560x445

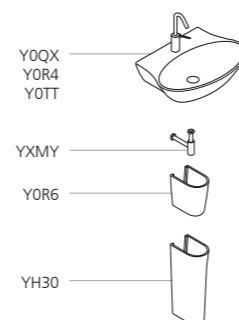



NIDO 75

Lavabo da 75 cm in appoggio. Può essere installato su piano o su base SLIDING WOOD SYSTEM ed è utilizzabile con rubinetteria a parete o sul piano d'appoggio. Senza troppopieno.

Lavabo de 75 cm à bord de vasque apparent. Installable sur plan de toilette ou avec SLIDING WOOD SYSTEM et utilisé avec robinetterie murale ou sur plan de toilette. Sans trop-plein.

75 cm surface-mounted washbasin. Can be installed on SLIDING WOOD SYSTEM base unit. No overflow.

Lavabo de 75 cm a apoyar. Puede ser instalado sobre una encimera o con SLIDING WOOD SYSTEM utilizando grifería de pared o encimera. Sin rebosadero.

Waschbecken 75 cm aufliegend oder mit SLIDING WOOD SYSTEM. Zur Montage auf Oberfläche verwendbar mit Wand- oder Waschtischarmaturen. Ohne Überlauf.

Накладной умывальник 75 см. Может устанавливаться на полку или на SLIDING WOOD SYSTEM и используется с настенными или в столешнице кранами. Без перелива.

installazione
installation



in appoggio
surface mounted

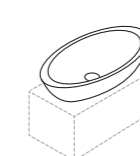
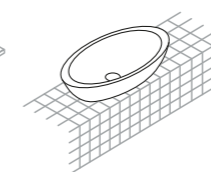
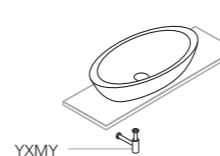

su base lavabo SLIDING WOOD SYSTEM
on SLIDING WOOD SYSTEM sink base unit

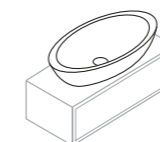

YOR2 
750x370



NIDO

bidet sospeso monoforo

Bidet sospeso completo di fissaggio speciale. Installazione con staffa universale per sospesi.

vaso sospeso

Vaso sospeso completo di fissaggio speciale. Installazione con staffa universale per sospesi. Integrabile con sedile frenato o non frenato.

bidet suspendu à un trou

Bidet suspendu avec kit de fixation spécial. Installation avec étrier universel pour éléments suspendus.

cuvette suspendu

Cuvette suspendue dotée de fixation spéciale. Installation avec étrier universel pour éléments suspendus. avec abattant avec ou sans système frein de chute abattant.

one-hole wall hung bidet

One-hole wall hung bidet with special fixing included. Mounted using universal bracket for wall-hung elements.

wall hung wc

Wall-hung WC with seat cover and special fixing. Mounted using universal bracket for wall-hung elements. Can be combined with soft-close or standard seat.

bidet suspendido de un orificio

Bidet suspendido completo de sistema de fijación especial. Instalación con estribo universal para artefactos suspendidos.

inodoro suspendido

Inodoro suspendido completo de sistema de fijación especial. Instalación con estribo universal para artefactos suspendidos. Integrable con asiento con caída amortiguada o no amortiguada.

Einlochbidet wandhängend

Wand-Bidet inklusive spezieller Halterung. Zur Montage mit universeller Wand-Halterung.

hänge-Wc

Hänge-Wc inklusive spezieller Halterung. Montage mit universeller Wandhalterung. Kann mit einem gebremsten oder nicht gebremsten Sitz ergänzt werden.

подвесное биде с одним отверстием

Подвесное биде в комплекте со специальным крепежом. Установка с универсальным кронштейном для подвесной сантехники.

унитаз подвесной

Чаша подвесная. Крепится на универсальную систему инсталляции для подвесной сантехники. Может быть укомплектована сиденьем с системой плавного закрывания крышки или с обычной крышкой.



368x550



363x548

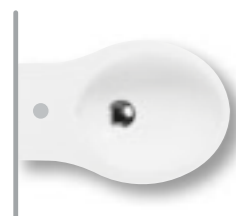

YXNI 

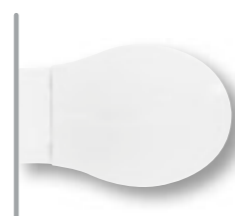

YXMD 





NIDO

bidet monoforo

Bidet a terra per installazione staccato dal muro. Uscita acqua dalla rubinetteria.

vaso scarico universale

Vaso scarico universale per installazione staccato dal muro. Da integrare con sedile frenato o non frenato, completo di curva tecnica di scarico.

bidet à un trou

Bidet posé au sol pour installation écartée du mur.

cuvette à vidange universelle

Cuvette vidange universelle pour installation écartée du mur. À intégrer au abattant avec système frein de chute abattant ou sans, tuyau coudé de vidange.

one-hole bidet

Floor-mounted bidet for installation away from the wall.

WC with universal outlet

WC with universal outlet, for installation away from the wall. To be combined with soft-close or standard seat cover, "s" trap convertor is inclusive.

bidé con un orificio

Bidé de tierra a instalar separado de la pared.

inodoro con descarga universal

Inodoro con descarga universal para instalar separado de la pared. A integrar con asiento frenado o no frenado.

Einloch-Bidet

Stand-Bidet zur Vorwandinstallation.

Wc mit Universal Abgang

Wc mit Universal Abgang zur Vorwandinstallation. Ergänztbar mit soft close Sitz oder normalem Sitz.

биде с одним отверстием

Напольное биде для установки на расстоянии от стены.

унитаз с универсальным сливом

Унитаз с универсальным сливом для установки на расстоянии от стены. Может быть дополнен сиденьем с механизмом плавного опускания или без него.



355x555



355x555



YXBU



YXBW WC

NIDO

bidet monoforo filo muro

Bidet completo di fissaggi per installazione a filo muro.

vaso scarico universale filo muro

Vaso scarico universale per installazione a filo muro. Da integrare con sedile frenato o non, completo di curva tecnica e fissaggio. Può essere abbinato alle cassette Monolith.

bidet à un trou monté au ras du mur

Bidet livré avec kit de fixation pour installation au ras du mur.

cuvette à vidange universelle a ras du mur

Cuvette à vidange universelle pour installation au ras du mur. À intégrer au abattant avec système frein de chute abattant ou sans, tuyau coudé et kit de fixation. Elle peut être associée aux chasses d'eau Monolith.

one-hole back-to-wall bidet

Bidet complete with fixing elements for back-to-wall installation.

back to wall WC with universal outlet

Back-to-wall universal outlet WC. To be combined with soft-close or standard seat cover, "s" trap convertor and fixing element are inclusive. Can be combined with Monolith cisterns.

bidé con un orificio a instalar contra la pared

Bidé completo de sistema de fijación para instalar contra la pared.

inodoro con descarga universal contra la pared

Inodoro con descarga universal para instalar contra la pared. A integrar con asiento frenado o no, curva técnica y sistema de fijación. Puede ser combinado a las cisternas Monolith.

Einloch-Bidet zur Wand-Montage

Bidet inklusive Halterungen zur Wand-Montage.

Wc mit Universal Abgang Zur Wandmontage

Wc mit Universal Abgang zur Wand-Montage. Ergänzt mit soft close Sitz oder normalem Sitz, technischer Kurve und Halterungen. Kombinierbar mit Monolith-Kästen.

пристенное биде с одним отверстием

Биде с комплекте с крепежом для пристенной установки.

унитаз с универсальным сливом

Унитаз с универсальным сливом для пристенной установки. Может быть дополнен сиденьем с механизмом плавного опускания ил без него, сливным коленом и крепежом. Может комбинироваться со смывными бачками серии Monolith.



360x555



360x555



YOQW



YOQU





NIDO

vaso monoblocco con cassetta

Vaso monoblocco scarico universale per installazione a filo muro. Con cassetta doppio scarico 3/6 litri entrata acqua laterale alta, bassa oppure posteriore, completo di curva tecnica di scarico. Da integrare con sedile frenato o non frenato.

cuvette monobloc avec chasses d'eau

Cuvette monobloc à vidange universelle pour installation au ras du mur. Intégrable au abattant avec système frein de chute abattant ou sans. À intégrer aux chasses d'eau avec arrivée d'eau latérale haute, basse ou postérieure.

coupled WC with cistern

One-piece universal outlet WC for back-to-wall installation. Can be combined with soft-close or standard seat cover. "S" trap convertor is inclusive. To be combined with cisterns with side top/bottom or back inlet system.

inodoro monobloque con cisterna

Inodoro monobloque con descarga universal para instalar contra la pared. Intégrable con asiento frenado o no. A integrar con cisternas de entrada de agua lateral alta, baja o bien, posterior.

Kompaktes Klosett mit Spülkasten

Monoblock-WC mit Universal Abgang zur Wand-Montage. Ergänztbar mit soft close Sitz oder normalem Sitz, mit Spülkasten mit Wassereingang seitlich, hoch, niedrig oder rückwärtig.

моноблочный унитаз с Бачок

Моноблочный унитаз с универсальным сливом для пристенной установки. Может комбинироваться с сиденьем с механизмом плавного опускания или без него. Должен быть дополнен смывным бачком с боковым верхним, нижним или задним подводом воды



355x655x803



Y0TQ WC
 Y0X0 3/6 L
 Y0X6 3/6 L
 Y0X7 3/6 L

NIDO

+ MONOLITH

Cassetta MONOLITH

Cassetta esterna in ceramica per installazione con vasi a filo muro. Meccanismo interno Geberit, doppio scarico 3/6 litri. Entrata acqua posteriore o laterale. Possibilità di installazione con scarico a terra variabile da 10 a 23 cm, oppure a parete.

Chasse d'eau MONOLITH

Chasse d'eau extérieure en céramique pour installation avec cuvette au ras du mur. Mécanisme Geberit avec double touche avec possibilité de réglage à 3 ou 6 litres. Arrivée d'eau arrière ou latérale. Possibilité d'installation avec vidange au sol allant de 10 à 23 cm, ou bien murale.

MONOLITH Cistern

Ceramic cistern to be used with back-to-wall WCs. Geberit 3/6 litre inner mechanism with dual flush. Back or side water inlet system Wall or floor outlet. The floor outlet can vary from 10 to 23 cm.

Cisterna MONOLITH

Cisterna externa de cerámica para instalación de inodoros contra la pared. Mecanismo interno Geberit, doble descarga 3/6 litros. Entrada de agua posterior o lateral. Posibilidad de instalación con descarga de tierra variable de 10 a 23 cm, o bien, de pared.

MONOLITH Kasten

Vorwand Kasten in Keramik zur Wandmontage. Innen Mechanismus Geberit, Doppelspülung 3/6 l. Wassereingang rückwärtig oder seitlich. Montagemöglichkeit mit senkrechtem oder waagerechtem Abgang, senkrechter Abgang variiert von 10 bis 23 cm.

бачок MONOLITH

Смывной керамический бачок для наружного монтажа к пристенным унитазам. Внутренний механизм Geberit, двойной слив 3-6 литров. Задний или боковой подвод воды. Возможна установка с регулируемым сливом в пол от 10 до 23 см или в стену.



370x685x900

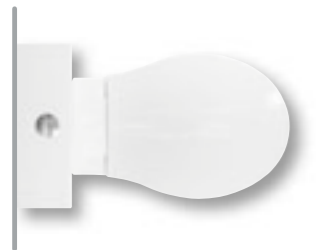

YOMK 
 YOYN 
 YOQU 





ERIKA pro / ERIKA pro Q

DESIGN NILO GIOACCHINI



ERIKA pro 120

Lavabo con doppio bacino, sospeso a muro.
Integrabile con 2 semicolonne oppure
con sifone a vista. Può essere installato su
mobile.

Double wall-hung washbasin. Can be
combined with 2 siphon covers or design
siphon. Can be fitted on countertop.

Doppelwaschbecken für die Wandmontage.
Kann mit 2 Halbsäulen oder mit einem
sichtbaren Siphon ergänzt bzw. auf einem
Möbel installiert werden.

Lavabo à double vasque, suspendu au mur.
Intégrable avec 2 demi-colonnes ou avec
siphon visible. Possibilité d'installation sur
meuble.

Lavabo con doble seno suspendido de pared.
Integrable con 2 semipedestales o sifón visto.
Puede ser instalado sobre mueble.

Умывальник с двойной раковиной
для пристенного монтажа. С двумя
полуколоннами или с открытым сифоном.
Может встраиваться в мебель.

installazione
installation



sospeso
wall hung

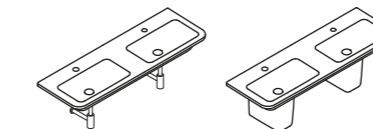

su mobile
on countertop

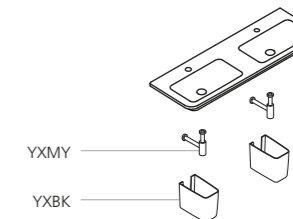
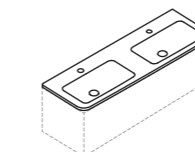

YXJC 
1200x450



ERIKA pro 100 - 80

Lavabi sospesi a muro. Integrabili con semicolonna oppure con sifone a vista. Possono essere installati su mobile.

Wall-hung washbasins. Can be combined with siphon cover or design siphon. Can be fitted on countertop.

Hängewaschbecken für die Wandmontage. Kann mit einer Halbsäule oder mit einem sichtbaren Siphon ergänzt bzw. auf einem Möbel installiert werden.

Lavabos suspendu au mur. Intégrable avec demi-colonne ou avec siphon visible. Possibilité d'installation sur meuble.

Lavabos suspendidos de pared. Integrale con semipedestal o sifón visto. Puedon ser instalados sobre mueble.

Раковина для пристенного монтажа. С полуколонной или открытым сифоном. Может встраиваться в мебель.

installazione
installation

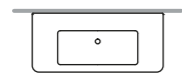

sospeso
wall hung

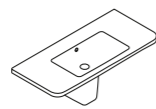
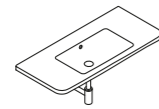

su mobile
on countertop

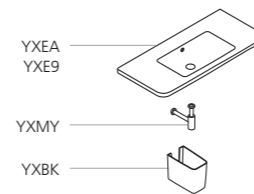
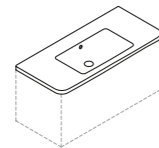

YXEA 
1000x450



YXE9 
800x450





ERIKA pro 65 - 60 - 55 - 45

Lavabi sospesi a muro. Integrabili con colonna, semicolonna oppure con sifone a vista. Possono essere installati su mobile.

Wall-hung washbasins. Can be combined with full column, siphon cover or design siphon. Can be fitted on countertop.

Hängewaschbecken für die Wandmontage. Kann mit einer Standsäule, einer Halbsäule oder mit einem sichtbaren Siphon ergänzt bzw. auf einem Möbel installiert werden.

Lavabos suspendus au mur. Intégrables avec colonne, demi-colonne ou avec siphon visible. Possibilité d'installation sur meuble.

Lavabos suspendidos de pared. Integrable con pedestal, semipedestal o sifón visto. Puedon ser instalados sobre mueble.

Подвесная раковина для пристенного монтажа. С колонной, полуколонной или с открытым сифоном. Может встраиваться в мебель.

installazione
installation



sospeso
wall hung

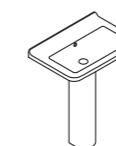
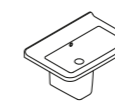
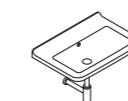
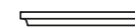

su mobile
on countertop

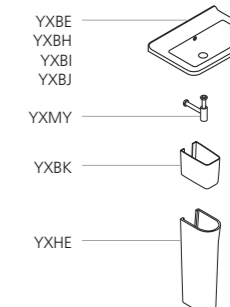
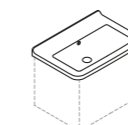

YXBE 650x450

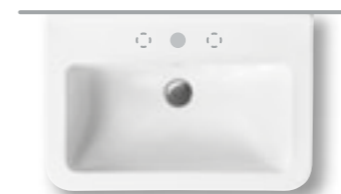

YXBH 600x450



YXBI 550x400



YXBJ 450x380



ERIKA pro 68 - 62

Lavabi sospesi a muro. Integrabili con colonna, semicolonna oppure con sifone a vista.

Wall-hung washbasins. Can be combined with full column, siphon cover or design siphon.

Hängewaschbecken für die Wandmontage. Kann mit einer Standsäule, einer Halbsäule oder mit einem sichtbaren Siphon ergänzt werden.

Lavabos suspendu au mur. Intégrable avec colonne, demi-colonne ou avec siphon visible.

Lavabos suspendidos de pared. Integrable con pedestal, semipedestal o sifón visto.

Раковина для пристенного монтажа. С колонной, полуколонной или с открытым сифоном.

installazione
installation

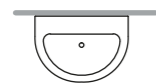

sospeso
wall hung

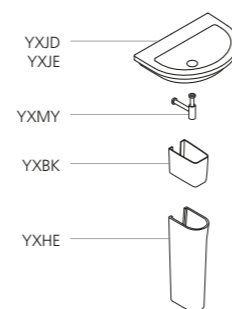
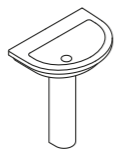
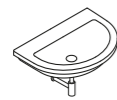

YXJD
680x480



YXJE
620x460





ERIKA pro Q

bidet sospeso monoforo

Bidet sospeso completo di fissaggio speciale. Installazione con staffa universale per sospesi.

vaso sospeso

Vaso sospeso completo di fissaggio speciale. Installazione con staffa universale per sospesi. Integrabile con sedile frenato o non frenato.

bidet suspendu à un trou

Bidet suspendu avec kit de fixation spécial. Installation avec étrier universel pour éléments suspendus.

cuvette suspendu

Cuvette suspendue dotée de fixation spéciale. Installation avec étrier universel pour éléments suspendus. avec abattant avec ou sans système frein de chute abattant.

one Hole Wall-hung Bidet

One-hole wall hung bidet with special fixing included. Mounted using universal bracket for wall-hung elements

wall-hung WC

Wall-hung WC with seat cover and special fixing. Mounted using universal bracket for wall-hung elements. Can be combined with soft-close or standard seat.

bidet suspendido de un orificio

Bidet suspendido completo de sistema de fijación especial. Instalación con estribo universal para artefactos suspendidos.

inodoro suspendido

Inodoro suspendido completo de sistema de fijación especial. Instalación con estribo universal para artefactos suspendidos. Integrable con asiento con caída amortiguada o no amortiguada.

Einlochbidet wandhängend

Wand-Bidet inklusive spezieller Halterung. Zur Montage mit universeller Wand-Halterung.

Hänge-Wc

Hänge-Wc inklusive spezieller Halterung. Montage mit universeller Wandhalterung. Kann mit einem gebremsten oder nicht gebremsten Sitz ergänzt werden.

биде подвесное с одним отверстием под смеситель

Чаша подвесная. Крепится на универсальную систему инсталляции для подвесной сантехники.

унитаз подвесной

Чаша подвесная. Крепится на универсальную систему инсталляции для подвесной сантехники. Может быть укомплектована сиденьем с системой плавного закрывания крышки или с обычной крышкой.



345x530



345x530

YXHW YXJ0 WC

ERIKA pro Q

bidet monoforo filo muro

Bidet completo di fissaggi per installazione a filo muro.

vaso scarico universale filo muro

Vaso scarico universale per installazione a filo muro. Da integrare con sedile frenato o non, completo di curva tecnica e fissaggio. Può essere abbinato alle cassette Monolith.

bidet à un trou monté au ras du mur

Bidet livré avec kit de fixation pour installation au ras du mur.

cuvette à vidange universelle a ras du mur

Cuvette à vidange universelle pour installation au ras du mur. À intégrer au abattant avec système frein de chute abattant ou sans, tuyau coudé et kit de fixation. Elle peut être associée aux chasses d'eau Monolith.

one-hole back-to-wall bidet

Bidet complete with fixing elements for back-to-wall installation.

back to wall WC with universal outlet

Back-to-wall universal outlet WC. To be combined with soft-close or standard seat cover, "s" trap convertor and fixing element are inclusive. Can be combined with Monolith cisterns.

bidé con un orificio a instalar contra la pared

Bidé completo de sistema de fijación para instalar contra la pared.

inodoro con descarga universal contra la pared

Inodoro con descarga universal para instalar contra la pared. A integrar con asiento frenado o no, curva técnica y sistema de fijación. Puede ser combinado a las cisternas Monolith.

Einloch-Bidet zur Wand-Montage

Bidet inklusive Halterungen zur Wand-Montage.

Wc mit Universal Abgang Zur Wandmontage

Wc mit Universal Abgang zur Wand-Montage. Ergänztbar mit soft close Sitz oder normalem Sitz, technischer Kurve und Halterungen. Kombinierbar mit Monolith-Kästen.

пристенное биде с одним отверстием

Биде с комплекте с крепежом для пристенной установки.

унитаз с универсальным сливом

Унитаз с универсальным сливом для пристенной установки. Может быть дополнен сиденьем с механизмом плавного опускания ил без него, сливным коленом и крепежом. Может комбинироваться со смывными бачками серии Monolith.



345x530



345x530



YXHU



YXHY WC





ERIKA pro Q

vaso monoblocco con cassetta

Vaso monoblocco scarico universale per installazione a filo muro completo di curva tecnica. Integrabile con sedile frenato o non frenato. In abbinamento cassetta quadre entrata acqua laterale alta oppure bassa, con meccanismo 3/6 lit preinstallato o non.

cuvette monobloc avec chassis d'eau

Cuvette monobloc à chasse d'eau universelle pour installation au ras du mur avec tuyau de vidange coudé. Intégrable avec abbattant avec ou sans système frein de chute abattant. Possibilité d'être intégrée aux chasses d'eau carrées avec arrivée d'eau latérale par le haut ou par le bas, avec ou sans mécanisme à double touche avec réservoir de chasse 3 ou 6 litres préinstallé.

coupled WC with cistern

One-piece universal outlet WC. Can be combined with soft-close or standard seat cover. "S" trap convertor is inclusive. To be combined with cisterns with side top/bottom or rear inlet system.

inodoro monobloque con cisterna

Inodoro monobloque con descarga universal para instalación a ras de la pared, dotado de curva técnica. Integrable con asiento con caída amortiguada o no amortiguada. En combinación con cisternas cuadradas entrada de agua lateral alta o baja, con mecanismo de 3/6 litros preinstalado o no.

Kompaktes Klosett mit Spülkasten

Kompaktes Klosett mit Universalabfluss zum Installieren direkt an der Wand, inklusive Abflussbogen. Kann mit einem gebremsten oder nicht gebremsten Sitz ergänzt werden. Zur Kombination mit eckigen Spülkästen mit Wasserzufuhr oben oder unten seitlich, mit der Möglichkeit eines bereits installierten Spülmechanismus für 3 bzw. 6 Liter.

унитаз моноблок

Чаша литая моноблок с универсальной схемой слива для пристенного монтажа в комплекте с сантехническим коленом для конвертирования выпуска. Может быть укомплектована сиденьем с системой плавного закрывания крышки или с обычной крышкой. Может устанавливаться с квадратными бачками для слива с боковым подводом воды сверху или снизу, с механизмом двойного слива, объем 3/6 л или без механизма.



370x625x805



- YXJ2 
- YXGR 
- YXGV 
- YXGT 
- YXGS 

ERIKA pro Q

+ MONOLITH

Cassetta MONOLITH

Cassetta esterna in ceramica per installazione con vasi a filo muro. Meccanismo interno Geberit, doppio scarico 3/6 litri. Entrata acqua posteriore o laterale. Possibilità di installazione con scarico a terra variabile da 10 a 23 cm, oppure a parete.

Chasse d'eau MONOLITH

Chasse d'eau extérieure en céramique pour installation avec cuvette au ras du mur. Mécanisme Geberit avec double touche avec possibilité de réglage à 3 ou 6 litres. Arrivée d'eau arrière ou latérale. Possibilité d'installation avec vidange au sol allant de 10 à 23 cm, ou bien murale.

MONOLITH Cistern

Ceramic cistern to be used with back-to-wall WCs. Geberit 3/6 litre inner mechanism with dual flush. Back or side water inlet system Wall or floor outlet. The floor outlet can vary from 10 to 23 cm.

Cisterna MONOLITH

Cisterna externa de cerámica para instalación de inodoros contra la pared. Mecanismo interno Geberit, doble descarga 3/6 litros. Entrada de agua posterior o lateral. Posibilidad de instalación con descarga de tierra variable de 10 a 23 cm, o bien, de pared.

MONOLITH Kasten

Vorwand Kasten in Keramik zur Wandmontage. Innen Mechanismus Geberit, Doppelspülung 3/6 l. Wassereingang rückwärtig oder seitlich. Montagemöglichkeit mit senkrechtem oder waagerechtem Abgang, senkrechter Abgang variiert von 10 bis 23 cm.

бачок MONOLITH

Смывной керамический бачок для наружного монтажа к пристенным унитазам. Внутренний механизм Geberit, двойной слив 3-6 литров. Задний или боковой подвод воды. Возможна установка с регулируемым сливом в пол от 10 до 23 см или в стену.



370x660x900



YOMK 
 YOYN 
 YXHY 





ERIKA pro

bidet sospeso monoforo

Bidet sospeso. Da installare con staffa universale per sospesi.

vaso sospeso

Installazione con staffa universale per sospesi. Integrabile con sedile frenato o non frenato.

bidet suspendu à un trou

Bidet suspendu. À installer avec étrier universel pour éléments suspendus.

cuvette suspendu

Installation avec étrier universel pour éléments suspendus. avec abattant avec ou sans système frein de chute abattant.

one Hole Wall-hung Bidet

Wall-hung bidet. To be installed with universal bracket for wall hung sanitary ware.

wall-hung WC

Mounted using universal bracket for wall-hung elements. Can be combined with soft-close or standard seat.

bidé suspendido con orificio único

Bidé suspendido. A instalar con elemento de fijación universal para sanitarios suspendidos.

inodoro suspendido

Instalación con estribo universal para artefactos suspendidos. Integrable con asiento con caída amortiguada o no amortiguada.

Einloch-Hängebidet

Hängebidet. Installation mit einem Universalbügel für hängende sanitäre Einrichtungen.

Hänge-Wc

Montage mit universeller Wandhalterung. Kann mit einem gebremsten oder nicht gebremsten Sitz ergänzt werden.

биде подвесное с одним отверстием под смеситель

Чаша подвесная. Крепится на универсальную систему инсталляции для подвесной сантехники.

унитаз подвесной

Может быть укомплектована сиденьем с системой плавного закрывания крышки или с обычной крышкой.



370x530



370x530



YXBT



YXBS WC

ERIKA pro

bidet monoforo

Bidet a terra per installazione staccato dal muro. Uscita dell'acqua dalla rubinetteria.

vaso scarico universale

Vaso scarico universale per installazione staccato dal muro, completo di curva tecnica di scarico. Da integrare con sedile frenato o non frenato.

bidet à un trou

Bidet au sol pour installation écartée du mur. Arrivée d'eau de la robinetterie.

cuvette à chasse d'eau universelle

Cuvette à chasse d'eau universelle pour installation écartée du mur avec tuyau de vidange coudé. À intégrer avec abbattant avec ou sans système frein de chute abattant.

one hole Bidet

Floor-mounted bidet to be installed away from the wall. Water outlet from taps.

WC with Universal Outlet

WC with universal outlet, for installation away from the wall. To be combined with soft-close or standard seat cover, "s" trap convertor is inclusive.

bidé con orificio único

Bidé a suelo para instalación separada de la pared. Salida del agua de la grifería.

inodoro con descarga universal

Inodoro con descarga universal para instalación separada de la pared, dotado de curva técnica de descarga. A integrar con asiento con caída amortiguada o no amortiguada.

Einloch-Bidet

Bidet, Installation am Boden mit Abstand von der Wand. Wasserauslass an den Armaturen.

Universal-Klosett

Universalklosett, Installation mit Abstand von der Wand, inklusive Abflussbogen. Zur Ergänzung mit einem gebremsten oder nicht gebremsten Sitz.

биде с одним отверстием под смеситель

Чаша для напольного монтажа на расстоянии от стены. Излив воды из смесителя.

унитаз с универсальной схемой слива

Чаша с универсальной схемой слива для напольного монтажа на расстоянии от стены в комплекте с сантехническим коленом для конвертирования выпуска. Может быть укомплектована сиденьем с системой плавного закрывания крышки или с обычной крышкой.



370x535



370x530



YXBP



YXBR WC





ERIKA pro

vaso monoblocco con cassetta

Vaso monoblocco scarico universale completo di curva tecnica di scarico. Integrabile con sedile frenato o non frenato. In abbinamento cassetta tonde entrata acqua laterale alta oppure bassa, con meccanismo 3/6 lit preinstallato o non.

cuvette monobloc avec chassis d'eau

Cuvette monobloc à chasse d'eau universelle avec tuyau de vidange coudé. À intégrer avec abattant avec ou sans système frein de chute abattant. Possibilité de chasses d'eau ronde à arrivée d'eau latérale par le haut ou par le bas, avec ou sans mécanisme à double touche avec réservoir de chasse 3 ou 6 litres préinstallé.

coupled WC with cistern

One-piece universal outlet. Can be combined with soft-close or standard seat cover. "S" trap convertor is inclusive. To be combined with cisterns with side top/bottom or back inlet system.

inodoro monobloque con cisterna

Inodoro monobloque con descarga universal, dotado de curva técnica de descarga. Integrable con asiento con caída amortiguada o no amortiguada. En combinación con cisternas redondas entrada de agua lateral alta o baja, con mecanismo de 3/6 litros preinstalado o no.

Kompaktes Klosett mit Spülkasten

Kompaktes Klosett mit Universalabfluss inklusive Abflussbogen. Kann mit einem gebremsten oder ungebremsten Sitz ergänzt werden. Zur Kombination mit runden Spülkästen mit Wasserzufuhr oben oder unten seitlich, mit der Möglichkeit eines bereits installierten Spülmechanismus für 3 bzw. 6 Liter.

унитаз моноблок

Чаша литая моноблок с универсальной схемой слива в комплекте с сантехническим коленом для конвертирования выпуска. Может быть укомплектована сиденьем с системой плавного закрывания крышки или с обычной крышкой. Может устанавливаться с круглыми бачками для слива с боковым подводом воды сверху или снизу, с механизмом двойного слива, объем 3/6 л или без механизма.



370x675x778



- YXBQ WC
- YXG3 3/6 L
- YXG7 3/6 L
- YXG5
- YXG2



SLIDING wood system

DESIGN NILO GIOACCHINI



SLIDING wood system

COLONNA TALL UNIT HOCHSCHRANK ETAGERE MURALE COLUMNA ШКАФ-КОЛОННА_ 140 - 120 - 100

Colonna sospesa ad 1 anta, apertura destra o sinistra. Disponibile nelle misure 140 - 120 - 100 cm nelle finiture wengè e noce.

Tall unit. One right or left door. Available in 140 - 120 - 100 cm wengè and nut finishing.

Hängehochschrank mit 1 Tür, Öffnung links oder rechts. Erhältlich sind die Größen 140 - 120 - 100 cm in Wenge und Nussbaum.

Etagère murale 1 porte, ouverture à droite ou à gauche. Disponible en 140 - 120 - 100 cm en wengè et bois de noyer

Columna de pared con 1 puerta, apertura derecha o izquierda. Disponible en las medidas 140 - 120 - 100 cm en acabado wengè y nogal.

Подвесной шкаф-колонна с 1 створкой, открывается вправо или влево. Размеры 140/120/100 см, отделка под венге и орех.

installazione
installation

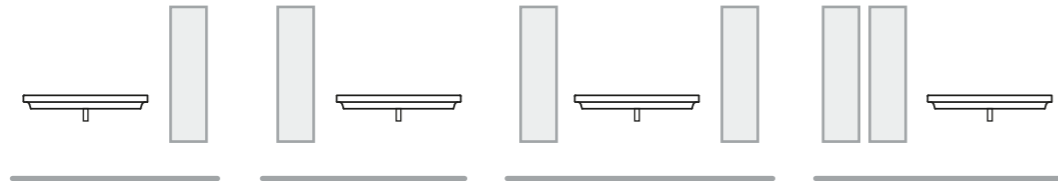

misure - apertura
measures - opening

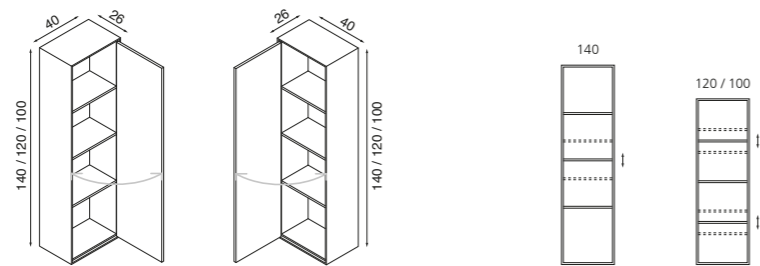

finiture mobile
unit finishing

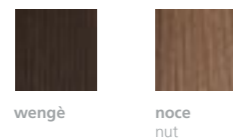

wengè

noce
nut

finiture anta
door finishing

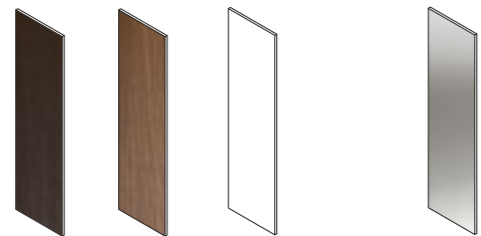

wengè

noce
nut

laccato bianco lucido
glossy white

specchio*
mirror

* La finitura a specchio è solo all'esterno
The mirror finish is on the outside only





SLIDING wood system

COLONNA A GIORNO TALL OPEN UNIT OFFENER HOCHSCHRANK ETAGERE OUVERTE
 COLUMNA ABIERTA ОТКРЫТЫЙ ШКАФ-КОЛОННА_140

Colonna sospesa 140 cm ad 1 anta, apertura destra o sinistra. Disponibile nelle finiture wengè e noce.

140 cm open tall unit 1 door right or left. Available in wengè and nut finishing.

Hängehochschrank 140 cm mit 1 Tür, Öffnung links und rechts. Erhältlich in Wenge und Nussbaum.

Etagère suspendue ouverte 140 cm 1 porte ; ouverture à droit et à gauche. Disponible en wengé et bois de noyer.

Columna de pared de 140cm con 1 puerta, apertura derecha o izquierda. Disponible en acabado wengé y nogal.

Подвесной шкаф-колонна 140 см с 1 створкой, открывается вправо или влево. Отделка под венге и орех.

installazione
 installation

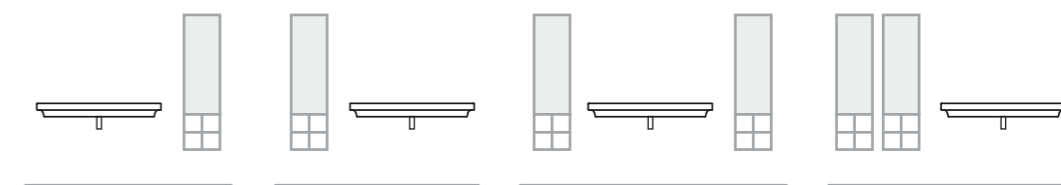

misure - apertura
 measures - opening

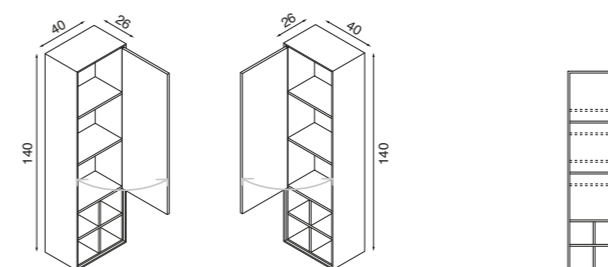

finiture mobile
 unit finishing

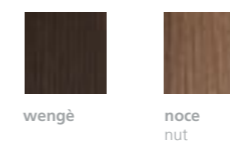

finiture anta
 door finishing



* La finitura a specchio è solo all'esterno
 The mirror finish is on the outside only

SLIDING wood system

PENSILE UNIT HÄNGESCHRANK ELEMENT MURAL HORIZONTAL
MÓDULO ALTO ПОВЕСНАЯ ПОЛКА_140 - 120 - 100

Pensile orizzontale ad 1 anta, apertura alta o bassa. Disponibile nelle misure 140 - 120 - 100 cm nelle finiture wengè e noce.

Horizontal unit. One lift up or flip down door. Available in 140 - 120 - 100 cm wengè and nut finishing.

Waagerechter Hängeschrank mit 1 Tür, Öffnung oben oder unten. Erhältlich sind die Größen 140 - 120 - 100 cm in Wenge und Nussbaum.

Élément mural horizontal 1 battant ; ouverture du dessous et du dessus . Disponible en 140 - 120 - 100 en wengé et bois de noyer .

Módulo alto horizontal con 1 puerta, apertura alta o baja. Disponible en las medidas 140 - 120 - 100 cm en acabado wengé y nogal.

Горизонтальная подвесная полка с 1 створкой, верхний или нижний замок. Размеры 140 - 120 - 100 см, отделка под венге и орех.

installazione installation

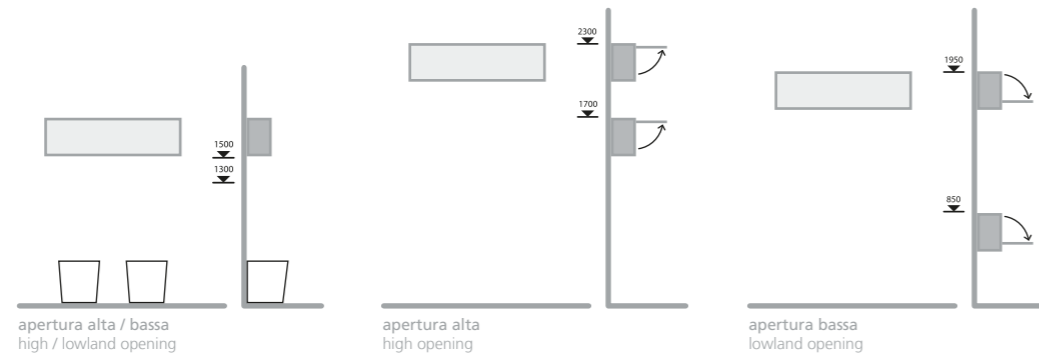

misure - apertura measures - opening

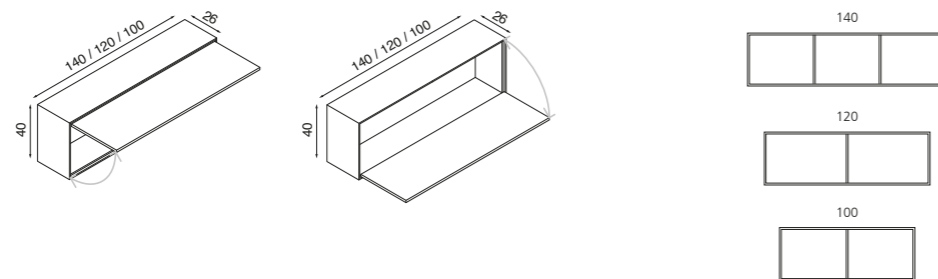

finiture mobile unit finishing

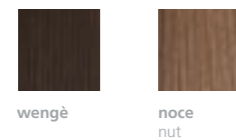

finiture anta door finishing



* La finitura a specchio è solo all'esterno
The mirror finish is on the outside only





SLIDING wood system

PENSILE A GIORNO OPEN UNIT OFFENER HÄNGESCHRANK ELEMENT MURAL HORIZONTAL
OUVERT MÓDULO ALTO ABIERTO ОТКРЫТАЯ ПОДВЕСНАЯ ПОЛКА_140 - 120 - 100

Pensile orizzontale a giorno. Disponibile nelle misure 140 - 120 - 100 cm nelle finiture wengè e noce.

Horizontal unit. Available in 140 - 120 - 100 cm wengè and nut finishing.

Offener waagerechter Hängeschrank. Erhältlich sind die Größen 140 - 120 - 100 cm in Wenge und Nussbaum.

Élément mural horizontal ouvert. Disponible en 140 - 120 - 100 en wengè et bois de noyer.

Módulo alto horizontal abierto. Disponible en las medidas 140 - 120 - 100 cm en acabado wengè y nogal.

Открытая горизонтальная подвесная полка. Размеры 140 - 120 - 100 см, отделка под венге и орех.

installazione
installation

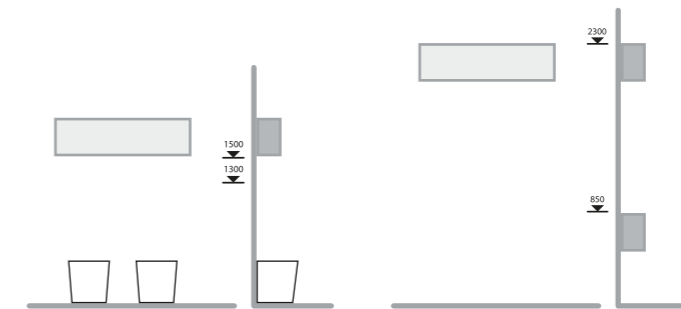

misure
measures

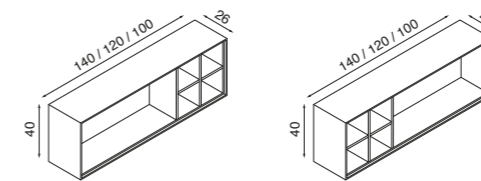

finiture mobile
unit finishing

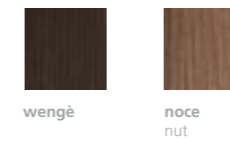

SLIDING wood system

BASE SIDE UNIT UNTERSCHRANK ELEMENT BASE 1 TIROIR
 BASE ПОДСТАВКА_ 120 - 100 - 80

Base ad 1 cassetto. Per installazione laterale al lavabo. Disponibile nelle misure 120 - 100 - 80 cm nelle finiture wengè e noce.

One drawer side unit. Available in 120 - 100 - 80 cm wengè and nut finishing.

Unterschrank mit 1 Schublade. Für die seitliche Anbringung am Waschbecken. Erhältlich sind die Größen 120 - 100 - 80 cm in Wenge und Nussbaum.

Élément base 1 tiroir ; à installer latéralement au lavabo. Disponible en 120 - 100 - 80 en wengè et bois de noyer.

Mueble base con 1 cajón. Para instalación al lado del lavabo. Disponible en las medidas 120 - 100 - 80 cm en acabado wengè y nogal.

Передвижная подставка с 1 ящиком. Для установки сбоку от умывальника. Размеры 120 - 100 - 80 см, отделка под венге и орех.

installazione
 installation

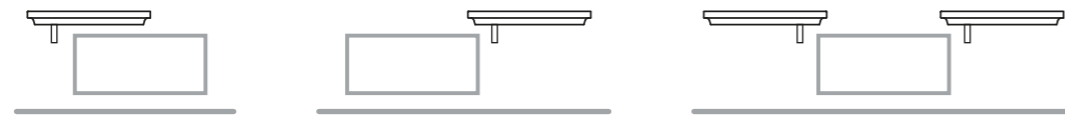

misure - apertura
 measures - opening

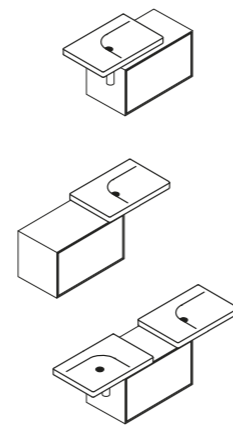
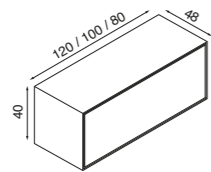

finiture mobile
 unit finishing

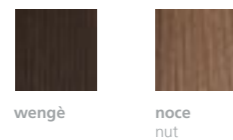

finiture cassetto
 drawer finishing

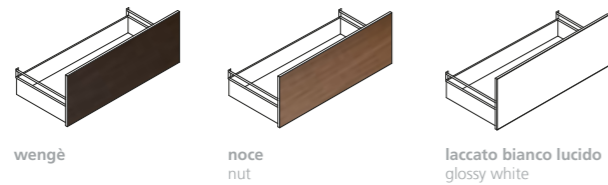



SLIDING wood system

BASE LAVABO / SPECCHIO SINK BASE UNIT / MIRROR UNTERSCHRANK FÜR WASCHBECKEN / SPIEGEL
 BASE POUR LAVABO / MIRROIR BASE PARA LAVABO / ESPEJO ПОДСТАВКА ПОД УМЫВАЛЬНИК /
 ЗЕРКАЛО_ 120 - 100 - 80

Base da appoggio per lavabi. 1 cassetto.
 Disponibile nelle misure 120 - 100 - 80 cm
 nelle finiture wengè e noce.
 Specchio orizzontale con illuminazione led
 inclusa. Disponibile nelle misure 120 - 100 -
 80 cm nelle finiture wengè e noce.

Sink base unit for surface-mounted washbasins.
 1 drawer. Available in 120 - 100 - 80 cm wengè
 and nut finishing. Horizontal mirror with led
 lighting included. Available in 120 - 100 - 80 cm
 wengè and nut finishing.

Unterschrank für Waschbecken 1 Schublade.
 Erhältlich sind die Größen 120 - 100 - 80
 cm in Wenge und Nussbaum. Waagerechter
 Spiegel mit LED-Beleuchtung. Erhältlich sind
 die Größen 120 - 100 - 80 cm in Wenge und
 Nussbaum.

Élément base pour lavabo 1 tiroir . Disponible
 en 120 - 100 - 80 cm en wengé et bois de
 noyer . Miroir horizontal avec éclairage à LED .
 Disponible en 120 - 100 - 80 cm en wengé et
 bois de noyer .

Base de apoyo para lavabos. 1 cajón.
 Disponible en las medidas 120 - 100 - 80 cm
 en acabado wengé y nogal.
 Espejo horizontal con iluminación led incluida.
 Disponible en las medidas 120 - 100 - 80 cm
 en acabado wengé y nogal.

Подставка под умывальники. 1 ящик.
 Размеры 120 - 100 - 80 см, отделка под
 венге и орех.
 Горизонтальное зеркало в комплекте с
 освещением. Размеры 120 - 100 - 80 см,
 отделка под венге и орех.

installazione
 installation

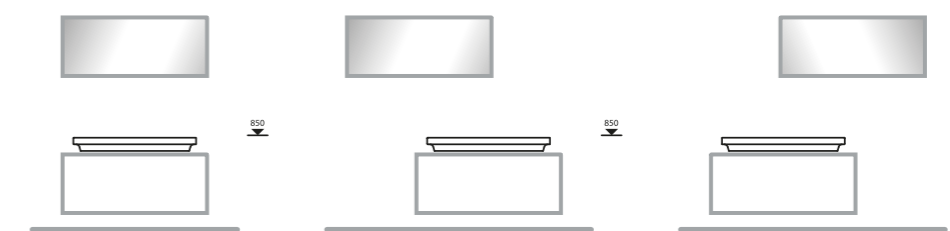

misure
 measures

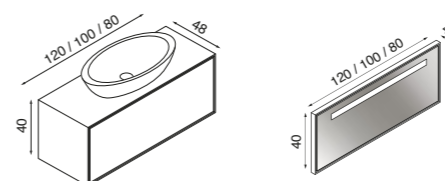

Lavabi d'appoggio
 Surface-mounted washbasins

G-100
 G-75 dx / sx
 G-50 dx / sx
 AREA 100x35
 AREA 80x35
 YOU & ME 90
 YOU & ME 80
 YOU & ME 70
 HAPPY HOUR 02:00
 HAPPY HOUR 03:00
 HAPPY HOUR 07:00
 HAPPY HOUR 10:00
 HAPPY HOUR 11:00
 HAPPY HOUR 17:00
 HAPPY HOUR 22:00
 NIDO 62
 NIDO 68
 NIDO 75

finiture
 finishing

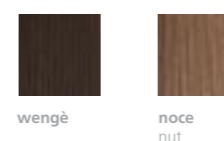

wengè

noce

nut

finiture cassetto
 drawer finishing

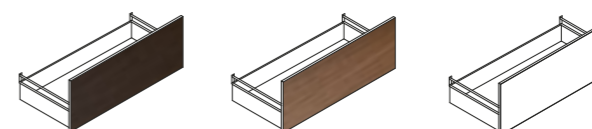

wengè

noce

nut

laccato bianco lucido

glossy white

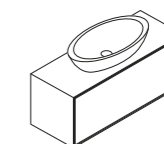

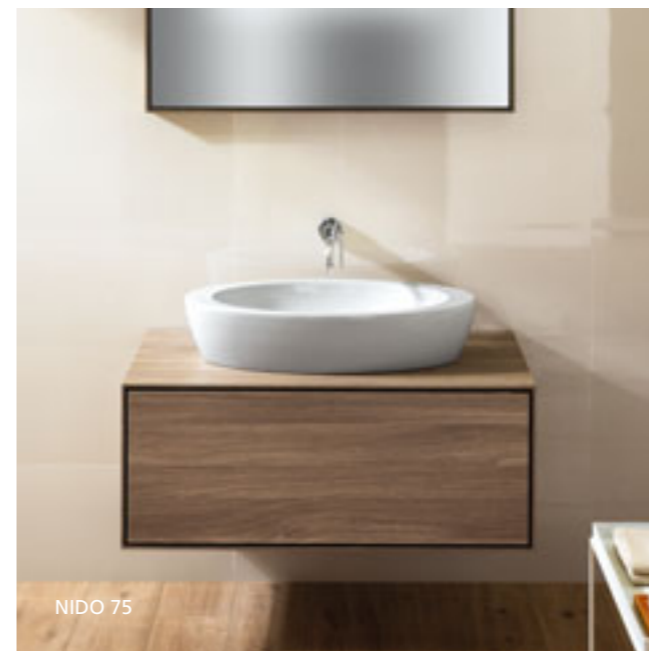
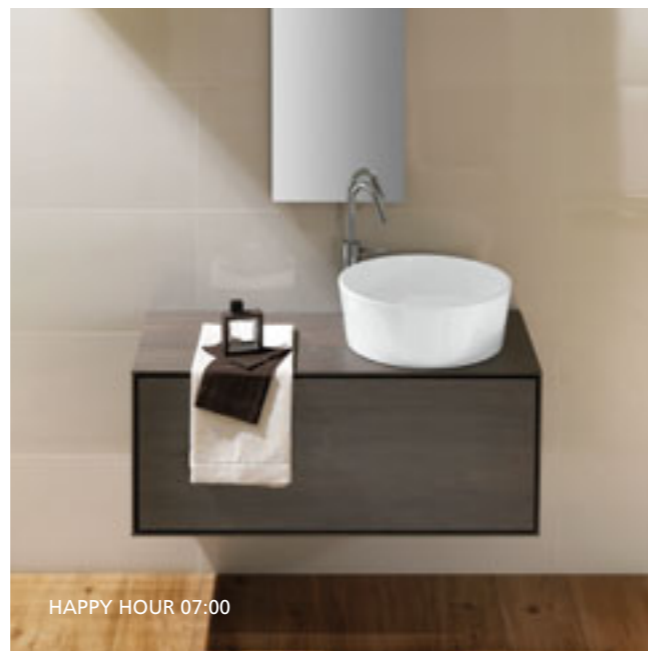
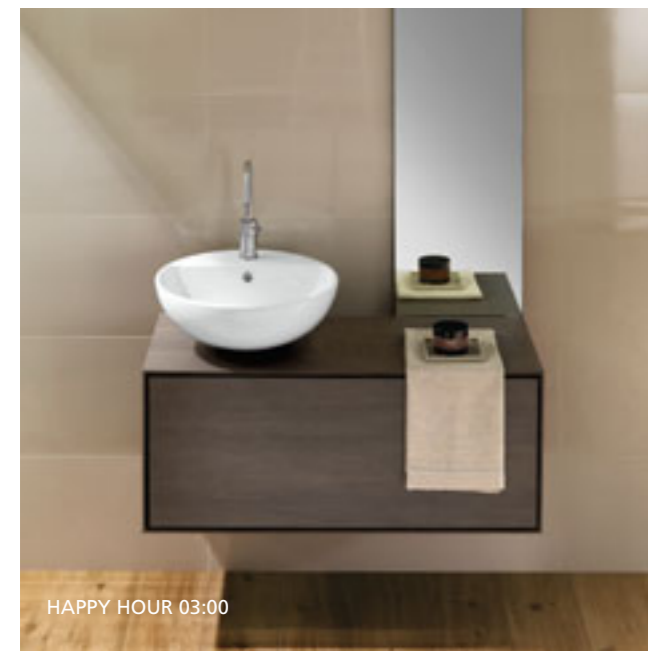
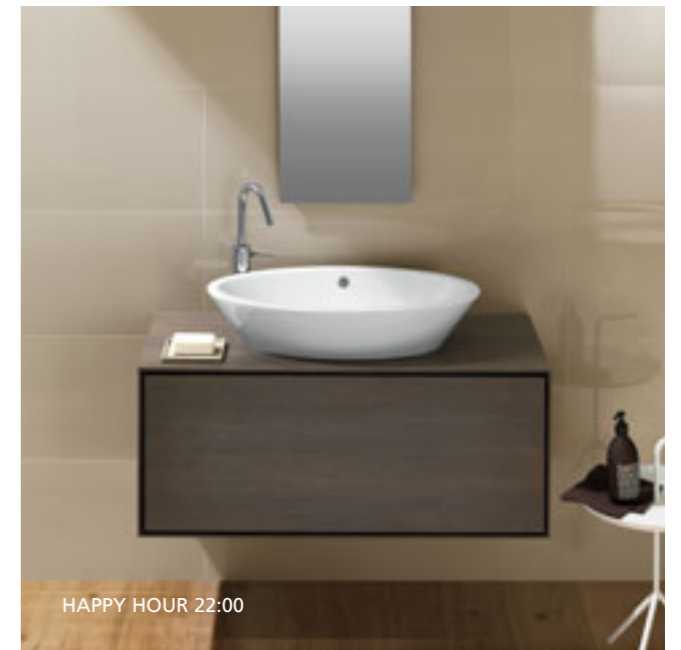
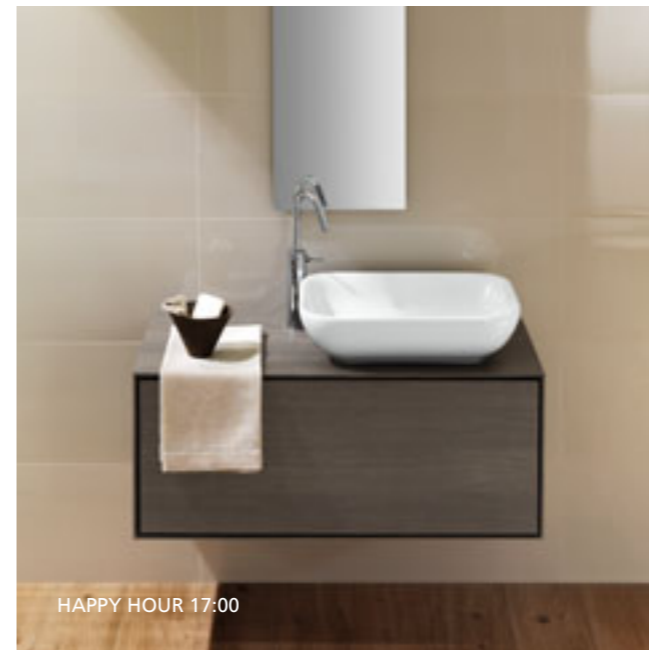
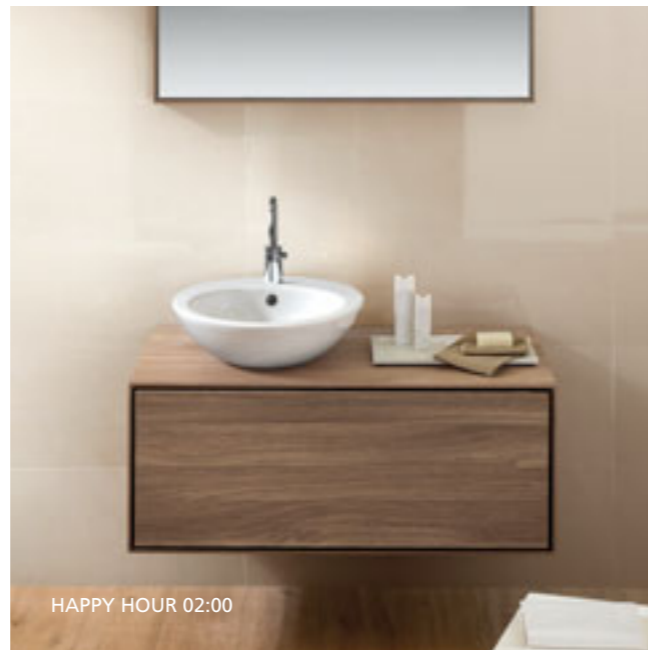
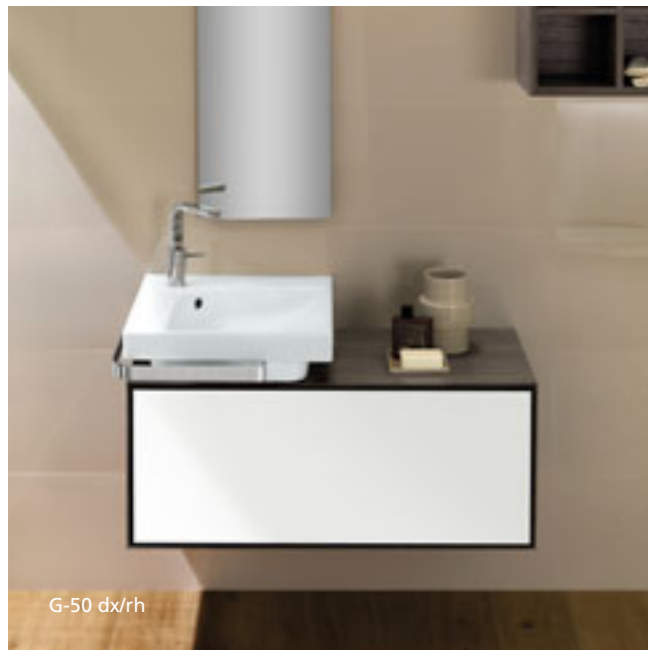
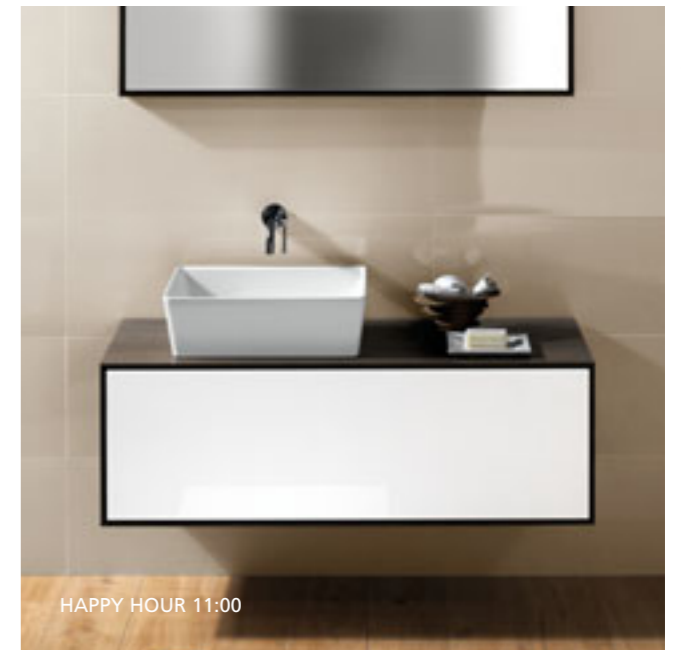
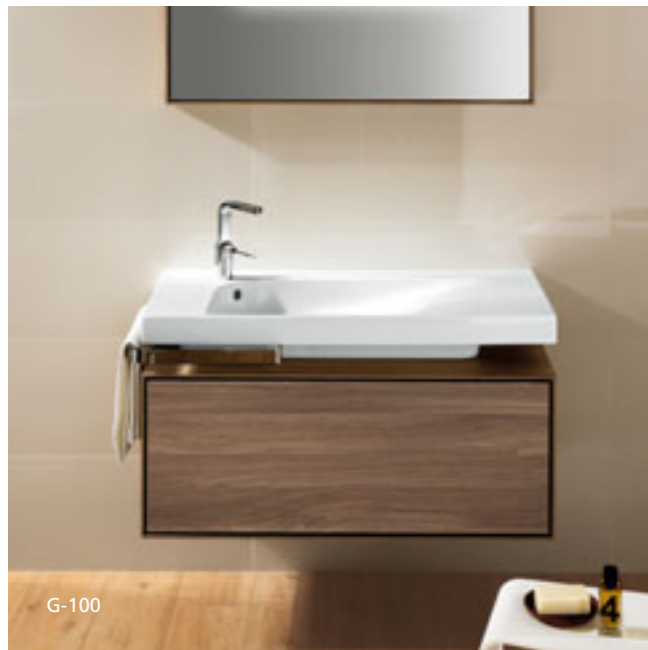

SLIDING wood system

	taglio 1 cut 1						taglio 2 cut 2					
	centrale central			laterale SX LH lateral		laterale DX RH lateral		centrale central			laterale SX LH lateral	
	120	100	80	120	100	120	100	120	100	80	120	100
YXER/YXNR G-50 dx/rh				●	●							
YXES/YXNU G-50 sx/lh						●	●					
YXET/YXNT G-75 dx/rh				●	●							
YXEU/YXNS G-75 sx/lh						●	●					
Y0VA G-100				●	●							
Y0UF AREA 80x35								●	●		●	●
Y0R2 NIDO 75								●	●	●	●	●
Y0M6 HAPPY HOUR 02:00										●	●	●
YXSJ HAPPY HOUR 03:00										●	●	●
YXSK HAPPY HOUR 07:00								●	●	●	●	●
Y0QR HAPPY HOUR 10:00										●	●	●
YXSL HAPPY HOUR 11:00								●	●	●	●	●
Y0QQ HAPPY HOUR 17:00								●	●	●	●	●
Y0M9 HAPPY HOUR 22:00								●	●	●	●	●
Y0W1 AREA 100x35												
YXEM NIDO 62	●	●	●	●	●	●	●					
YXEP NIDO 68	●	●	●	●	●	●	●	●	●	●	●	●
Y0UJ YOU & ME 70	●	●	●									
Y0UT YOU & ME 80								●	●		●	
Y0UK YOU & ME 90	●	●										

	taglio 3 cut 3										taglio 4 cut 4	
	laterale DX RH lateral		centrale central			laterale SX LH lateral		laterale DX RH lateral		doppio double		
	120	100	120	100	80	120	100	120	100	120		
	●	●										
	●	●										

RIASSUNTO ERGONOMICO DELLE POSIZIONI DI UTILIZZO

ERGONOMIC SUMMARY OF THE POSSIBLE POSITIONS

PENSILE GIORNO | OPEN UNIT

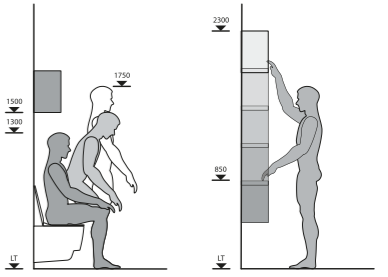

H. MIN. POSIZIONAMENTO PENSILE CONTENITORE SOPRA I VASI | MIN. H. THE WALL-HUNG ELEMENT CAN BE POSITIONED ABOVE THE BOWL

MIN. E MAX. H. ASSOLUTA DI POSIZIONAMENTO DEL PENSILE CONTENITORE LIBERO | MIN. AND MAX. ABSOLUTE H. AT WHICH THE FREE WALL-HUNG CABINET CAN BE POSITIONED

BASE | SIDE UNIT
BASE LAVABO | SINK BASE UNIT

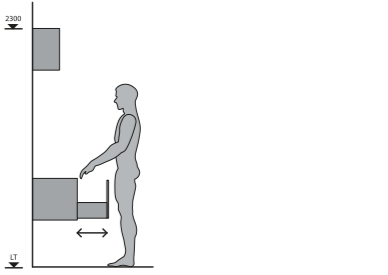

BASE CONTENITORE CON CASSETTO | CABINET BASE WITH DRAWER

PENSILE ANTA APERTURA ALTA | UNIT LIFT UP DOOR

PENSILE ANTA APERTURA BASSA | UNIT FLIP DOWN DOOR

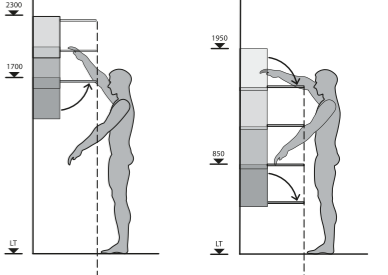

COLONNE UNITS

COLONNE UNITS

MIN. E MAX. H. ASSOLUTA DI POSIZIONAMENTO DEL PENSILE CONTENITORE CON APERTURA VERSO L'ALTO | MIN. AND MAX. ABSOLUTE H. AT WHICH THE UPWARD-OPENING CABINET CAN BE POSITIONED

MIN. E MAX. H. ASSOLUTA DI POSIZIONAMENTO DEL PENSILE CONTENITORE CON APERTURA VERSO IL BASSO | MIN. AND MAX. ABSOLUTE H. AT WHICH THE DOWNWARD-OPENING CABINET CAN BE POSITIONED

INGOMBRO INVARIATO PER APERTURA ANTA ORIZZONTALE O VERTICALE | HORIZONTAL OR VERTICAL OPENING ELEMENTS TAKE UP THE SAME SPACE



LIF.ST showertrays

DESIGN NILO GIOACCHINI



LIF.ST 160x80

HEAVYCRIL

Piatto doccia in Heavycril con scarico da 90 mm estraibile e di facile manutenzione. Copripiletta quadrato. Installazione a filo pavimento o in appoggio. Può essere tagliato o rifilato sul bordo. Montaggio con scarico verso il muro o opposto. Piletta di scarico (YXEV) non inclusa.

Receveur de douche en Heavycril avec tirette de 90 mm, bonde de vidage extractible et entretien facile. Couvercle carré. Pose au ras du sol ou avec bord apparent. Il peut être coupé ou rogné sur le bord. Montage avec vidange côté mur ou à l'opposé. Bonde de vidage (YXEV) pas compris.

Heavycril shower tray featuring removable easy-care 90 mm drain trap. Square-shaped drain cover. Flush-with-the-floor or floor-mounted installation. Can be cut or trimmed along the edge. Assembly with drain trap adjacent to or opposite wall. Siphon drainage (YXEV) not inclusive.

Ducha de Heavycril con descarga de 90 mm extraíble y de fácil mantenimiento. Cubredesagüe cuadrado. Instalación contra el pavimento o apoyado al mismo. Puede ser cortado o trinchado en el borde. Montaje con descarga hacia la pared o viceversa. Valvula de descarga (YXEV) not incluida.

Duschwanne in Heavycril mit 90 mm Ablauf, herausziehbar und von einfacher Handhabung. Quadratische Auslauf-Abdeckung. Bodenebene Installierung oder Aufsatz. Kann entlang den Ecken geschnitten oder beschnitten werden. Montage mit Ablauf in Wandrichtung oder anders herum. Ablaufsiphon (YXEV) nicht inbegriffen.

Душевой поддон Heavycril со съемным легкоочищаемым сливом 90 мм. Квадратная крышка сливного отверстия. Встроенная установка или с опорой на пол. Слив может быть обрезан или выровнен по кромке поддона. Монтаж со сливом ближе или дальше от стены.

installazione
installation

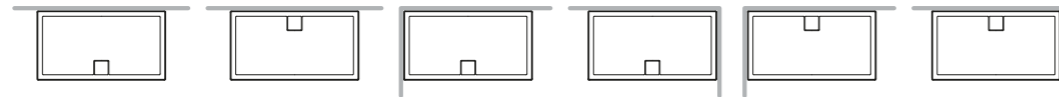

in appoggio
surface mounted



filo pavimento
flush with floor



YXEX

1600x800





LIF.ST 150x80 - 140x80

HEAVYCRIL

Piatto doccia in Heavycril con scarico da 90 mm estraibile e di facile manutenzione. Copripiletta quadrato. Installazione a filo pavimento o in appoggio. Può essere tagliato o rifilato sul bordo. Montaggio con scarico verso il muro o opposto. Piletta di scarico (YXEV) non inclusa.

Receveur de douche en Heavycril avec tirette de 90 mm, bonde de vidage extractible et entretien facile. Couvercle carré. Pose au ras du sol ou avec bord apparent. Il peut être coupé ou rogné sur le bord. Montage avec vidange côté mur ou à l'opposé. Bonde de vidage (YXEV) pas compris.

Heavycril shower tray featuring removable easy-care 90 mm drain trap. Square-shaped drain cover. Flush-with-the-floor or floor-mounted installation. Can be cut or trimmed along the edge. Assembly with drain trap adjacent to or opposite wall. Siphon drainage (YXEV) not inclusive.

Ducha de Heavycril con descarga de 90 mm extraible y de fácil mantenimiento. Cubredesagüe cuadrado. Instalación contra el pavimento o apoyado al mismo. Puede ser cortado o trinchado en el borde. Montaje con descarga hacia la pared o viceversa. Valvola de descarga (YXEV) not incluida.

Duschwanne in Heavycril mit 90 mm Ablauf, herausziehbar und von einfacher Handhabung. Quadratische Auslauf-Abdeckung. Bodenebene Installation oder Aufsatz. Kann entlang den Ecken geschnitten oder beschnitten werden. Montage mit Ablauf in Wandrichtung oder anders herum. Ablaufsiphon (YXEV) nicht inbegriffen.

Душевой поддон Heavycril со съёмным легкоочищаемым сливом 90 мм. Квадратная крышка сливного отверстия. Встроенная установка или с опорой на пол. Слив может быть обрезан или выровнен по кромке поддона. Монтаж со сливом ближе или дальше от стены.

installazione
installation



in appoggio
surface mounted



filo pavimento
flush with floor



YXF2
1500x800



YXEZ
1400x800



LIF.ST 120x80 - 100x80

CERAMICA CERAMIC KERAMIK CERAMIQUE CERAMICA КЕРАМИКИ

Piatto doccia in ceramica con scarico da 90 mm estraibile e di facile manutenzione. Copripiletta quadrato. Installazione a filo pavimento o in appoggio. Montaggio con scarico opposto al muro, lato non smaltato opposto alla pileta. Piletta di scarico (YXEV) non inclusa.

Receveur de douche en céramique avec tirette de 90 mm, bonde de vidage extractible et entretien facile. Couvercle carré. Pose au ras du sol ou avec bord apparent. Montage avec vidange côté mur, côté non émaillé opposé à la tirette. Bonde de vidage (YXEV) pas compris.

Ceramic shower tray featuring removable easycare 90 mm drain trap. Square-shaped drain cover. Flush-with-the-floor or floor-mounted installation. Assembly with drain trap on opposite side to wall, non-glazed side opposite drain trap. Siphon drainage (YXEV) not inclusive.

Ducha de cerámica con desagüe de 90 mm extraíble y de fácil mantenimiento. Cubredesagüe cuadrado. Instalación contra el pavimento o apoyado al mismo. Montaje con desagüe opuesto a la pared, lado no esmaltado opuesto al desagüe. Valvula de descarga (YXEV) not incluida

Duschwanne in Keramik mit 90 mm Ablauf, herausziehbar und von einfacher Handhabung. Quadratische Auslauf- Abdeckung. Bodenebene Installierung oder Aufsatz. Montage mit Ablauf in Wandgegenrichtung, nicht emaillierte Seite dem Ablauf entgegengesetzt. Ablaufsiphon (YXEV) nicht inbegriffen.

Душевой поддон из керамики со съёмным легкоочищаемым сливом 90 мм. Квадратная крышка сливного отверстия. Встроенная установка или с опорой на пол. Монтаж со сливом дальше от стены, неэмалированная сторона должна быть противоположна сливному отверстию.

installazione
installation

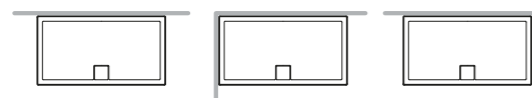

in appoggio
surface mounted

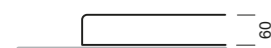

filo pavimento
flush with floor

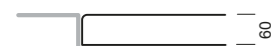

YXE8

1200x800



YXE7

1000x800





LIF.ST 120x70 - 100x70 - 90x70

CERAMICA CERAMIC KERAMIK CERAMIQUE CERAMICA КЕРАМИКИ

Piatto doccia in ceramica con scarico da 90 mm estraibile e di facile manutenzione. Copripiletta quadrato. Installazione a filo pavimento o in appoggio. Montaggio con scarico opposto al muro, lato non smaltato opposto alla pilettta. Piletta di scarico (YXEV) non inclusa.

Receveur de douche en céramique avec tirette de 90 mm, bonde de vidage extractible et entretien facile. Couvercle carré. Pose au ras du sol ou avec bord apparent. Montage avec vidange côté mur, côté non émaillé opposé à la tirette. Bonde de vidage (YXEV) pas compris.

Ceramic shower tray featuring removable easycare 90 mm drain trap. Square-shaped drain cover. Flush-with-the-floor or floor-mounted installation. Assembly with drain trap on opposite side to wall, non-glazed side opposite drain trap. Siphon drainage (YXEV) not inclusive.

Ducha de cerámica con desagüe de 90 mm extraible y de fácil mantenimiento. Cubredesagüe cuadrado. Instalación contra el pavimento o apoyado al mismo. Montaje con desagüe opuesto a la pared, lado no esmaltado opuesto al desagüe. Valvola de descarga (YXEV) not incluida

Duschwanne in Keramik mit 90 mm Ablauf, herausziehbar und von einfacher Handhabung. Quadratische Auslauf- Abdeckung. Bodenebene Installation oder Aufsatz. Montage mit Ablauf in Wandgegenrichtung, nicht emailierte Seite dem Ablauf entgegengesetzt. Ablaufsiphon (YXEV) nicht inbegriffen.

Душевой поддон из керамики со съёмным легкоочищаемым сливом 90 мм. Квадратная крышка сливного отверстия. Встроенная установка или с опорой на пол. Монтаж со сливом дальше от стены, неэмалированная сторона должна быть противоположна сливному отверстию.

installazione
installation

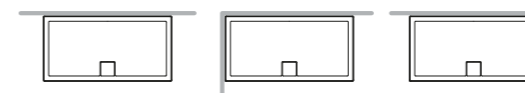

in appoggio
surface mounted

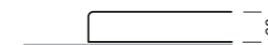

filo pavimento
flush with floor

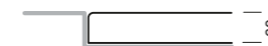

YXMI
1200x700



YXMJ
1000x700



YXMK
900x700



LIF.ST 90x90 - 80x80

CERAMICA CERAMIC KERAMIK CERAMIQUE CERAMICA КЕРАМИКИ

Piatto doccia in ceramica con scarico da 90 mm estraibile e di facile manutenzione. Copripiletta quadrato. Installazione a filo pavimento o in appoggio. Montaggio con scarico opposto al muro, lato non smaltato opposto alla piletta. Piletta di scarico (YXEV) non inclusa.

Receveur de douche en céramique avec tirette de 90 mm, bonde de vidage extractible et entretien facile. Couvercle carré. Pose au ras du sol ou avec bord apparent. Montage avec vidange côté mur, côté non émaillé opposé à la tirette. Bonde de vidage (YXEV) pas compris.

Ceramic shower tray featuring removable easycare 90 mm drain trap. Square-shaped drain cover. Flush-with-the-floor or floor-mounted installation. Assembly with drain trap on opposite side to wall, non-glazed side opposite drain trap. Siphon drainage (YXEV) not inclusive.

Ducha de cerámica con desagüe de 90 mm extraíble y de fácil mantenimiento. Cubredesagüe cuadrado. Instalación contra el pavimento o apoyado al mismo. Montaje con desagüe opuesto a la pared, lado no esmaltado opuesto al desagüe. Valvula de descarga (YXEV) not incluida.

Duschwanne in Keramik mit 90 mm Ablauf, herausziehbar und von einfacher Handhabung. Quadratische Auslauf- Abdeckung. Bodenebene Installierung oder Aufsatz. Montage mit Ablauf in Wandgegenrichtung, nicht emaillierte Seite dem Ablauf entgegengesetzt. Ablaufsiphon (YXEV) nicht inbegriffen.

Душевой поддон из керамики со съёмным легкоочищаемым сливом 90 мм. Квадратная крышка сливного отверстия. Встроенная установка или с опорой на пол. Монтаж со сливом дальше от стены, неэмалированная сторона должна быть противоположна сливному отверстию.

installazione
installation

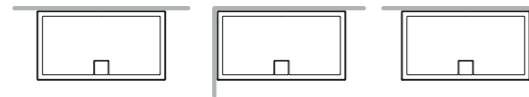

in appoggio
surface mounted



filo pavimento
flush with floor



YXE6
900x900



YXEK
800x800





i grandi
classici



YOU & ME

YOU & ME 92

Lavabo da 92 cm con doppio bacino, sospeso a muro, completo di fissaggi. Installabile anche in appoggio su piano.

Lavabo de 92 cm à double vasque, suspendu au mur, livré avec kit de fixation. Installable avec bord de vasque apparent sur plan de toilette.

Wall-hung 92 cm twin washbasin, complete with fixing elements. Can also be surface-mounted.

Lavabo de 92 cm con doble jofaina, suspendido en la pared, completo de sistema de fijación. También se puede apoyar sobre una encimera.

Waschbecken 92 cm mit doppeltem Becken, wandhängend, inklusive Halterungen. Auch zur Montage auf Ebene.

Подвесной настенный умывальник 92 см с двойной чашей в комплекте с крепежом. Может также устанавливаться на полку.

installazione
installation

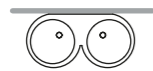

sospeso
wall hung



in appoggio
surface mounted

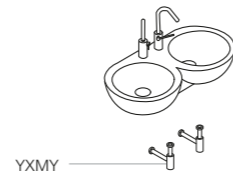
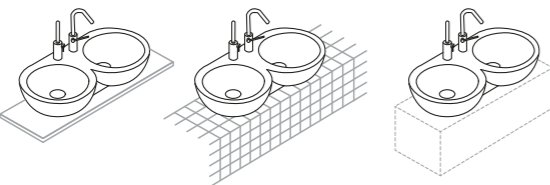
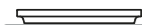

YXMY

YOHF 
920x460

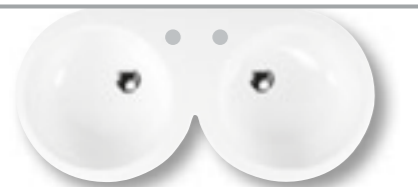



YOU & ME 90

Lavabo da 90 cm sospeso a muro, completo di fissaggi. Può essere installato anche in appoggio su piano o su base SLIDING WOOD SYSTEM.

Lavabo de 90 cm suspendu au mur, livré avec kit de fixation. Installable aussi avec bord de vasque apparent sur plan de toilette ou avec SLIDING WOOD SYSTEM.

90 cm wall-hung washbasin, complete with fixing elements. Can also be installed surface-mounted or on SLIDING WOOD SYSTEM sink base unit.

Lavabo de 90 cm suspendido en la pared, completo de sistema de fijación. También puede ser instalado sobre una encimera o con SLIDING WOOD SYSTEM.

Wand-Waschbecken 90 cm, inklusive Halterungen. Auch zur Montage aufliegend oder mit SLIDING WOOD SYSTEM.

Подвесной настенный умывальник 90 см в комплекте с крепежом. Может также устанавливаться на полку или на SLIDING WOOD SYSTEM.

installazione
installation

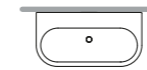

sospeso
wall hung

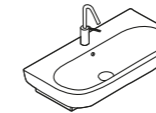

in appoggio
surface mounted

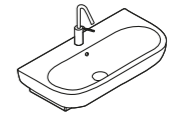
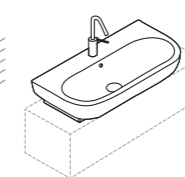
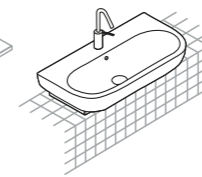
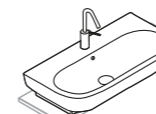
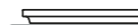

YXMY

su base lavabo SLIDING WOOD SYSTEM
on SLIDING WOOD SYSTEM sink base unit

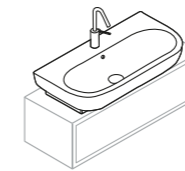

YOUK 
900x460

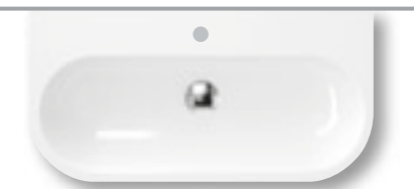

YOU & ME 80

Lavabo da 80 cm da installare in appoggio su piano o su base SLIDING WOOD SYSTEM. Senza troppopieno.

Lavabo de 80 cm à installer à bord de vasque apparent sur plan de toilette ou avec SLIDING WOOD SYSTEM. Sans trop-plein.

80 cm surface-mounted washbasin. Can be installed on SLIDING WOOD SYSTEM base unit. Without overflow.

Lavabo de 80 cm a instalar sobre una encimera o con SLIDING WOOD SYSTEM. Sin rebosadero.

Waschbecken 80 cm zur Montage aufliegend oder mit SLIDING WOOD SYSTEM. Ohne Überlauf.

Накладной умывальник 80 см устанавливается на полку или на SLIDING WOOD SYSTEM. Без перелива.

installazione
installation

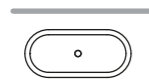

in appoggio
surface mounted

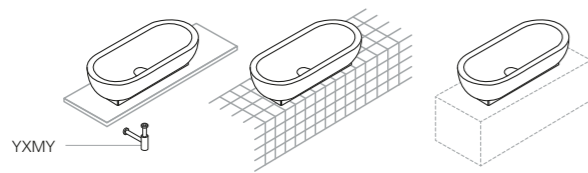

su base lavabo SLIDING WOOD SYSTEM
on SLIDING WOOD SYSTEM sink base unit

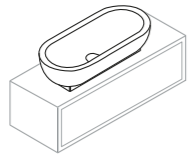

YOUT 
795x370





YOU & ME 70

Lavabo da 70 cm sospeso a muro, completo di fissaggi. Può essere installato anche in appoggio su piano o su base SLIDING WOOD SYSTEM.

70 cm wall-hung washbasin, complete with fixing elements. Can also be installed surface-mounted or on SLIDING WOOD SYSTEM base unit.

Wand-Waschbecken 70 cm, inklusive Halterungen. Auch zur Montage aufliegend oder mit SLIDING WOOD SYSTEM.

Lavabo de 70 cm suspendu au mur, livré avec kit de fixation. Installable aussi avec bord de vasque apparent sur plan de toilette ou avec SLIDING WOOD SYSTEM.

Lavabo de 70 cm suspendido en la pared, completo de sistema de fijación. También puede ser instalado sobre una encimera, o con SLIDING WOOD SYSTEM.

Подвесной настенный умывальник 70 см в комплекте с крепежом. Может также устанавливаться на полку или на SLIDING WOOD SYSTEM.

installazione
installation

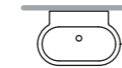

sospeso
wall hung

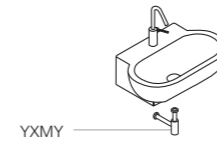

in appoggio
surface mounted

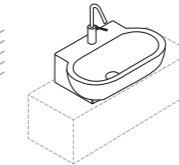
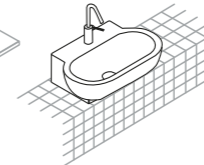
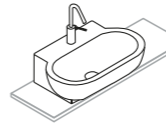

su base lavabo SLIDING WOOD SYSTEM
on SLIDING WOOD SYSTEM sink base unit

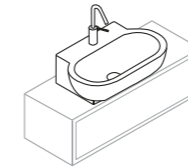

YXEN

YOUJ

703x445



YOU & ME 46

Lavabo da 46 cm sospeso a muro, completo di fissaggi. Nelle due versioni destro e sinistro, può essere installato ad angolo oppure a centro parete. Anche in appoggio su piano.

Lavabo de 46 cm suspendu au mur, livré avec kit de fixation. Réalisé dans les deux versions droite et gauche, il peut être installé en angle ou bien au centre du mur. Il peut également être installé avec bord de vasque apparent sur plan de toilette.

Wall-hung 46 cm washbasin, complete with fixing elements. Right-hand or left-hand versions. Can be mounted in the corner or the centre of the wall, or surface-mounted.

Lavabo de 46 cm suspendido en la pared, completo de sistema de fijación. En sus dos versiones, derecho e izquierdo, puede ser instalado en ángulo o bien, en el centro de la pared. También apoyado sobre una encimera.

Waschbecken 46 cm wandhängend, inklusive Halterungen. Rechts – oder linksseitig, mit verschiedenen Montagelösungen: über Eck oder wandmittig. Auch aufliegend.

Подвесной настенный умывальник 46 см в комплекте с крепежом. В правостороннем и левостороннем исполнении может устанавливаться в углу, в центре стены, а также на полке.

installazione
installation

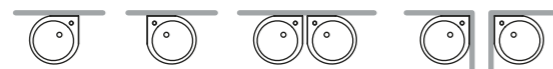

sospeso
wall hung

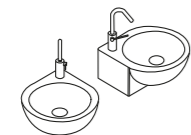

in appoggio
surface mounted

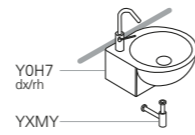
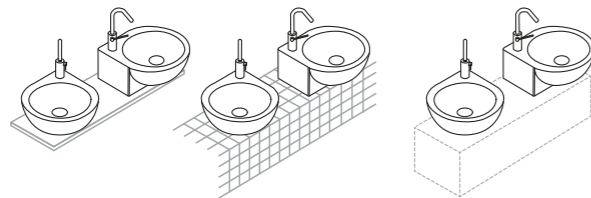

YXH7

dx/rh

YXMY

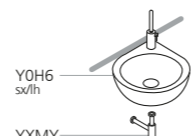

YXH6

sx/lh

YXMY

Y0H7 
460x460 dx - rh



Y0H6 
460x460 sx - lh





YOU & ME 46

Lavabo da 46 cm sospeso a muro, completo di fissaggi. Può essere installato anche in appoggio su piano.

Wall-hung 46 cm washbasin, complete with fixing elements. Can also be surface-mounted.

Wand-Waschbecken 46 cm, inklusive Halterungen. Auch zur Montage aufliegend.

Lavabo de 46 cm suspendu au mur, livré avec kit de fixation. Installable aussi avec bord de vasque apparent sur plan de toilette.

Lavabo de 46 cm suspendido en la pared, completo de sistema de fijación. También puede ser instalado sobre una encimera.

Подвесной настенный умывальник 46 см в комплекте с крепежом. Может также устанавливаться на полку.

installazione
installation



sospeso
wall hung

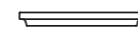

YXMY

in appoggio
surface mounted

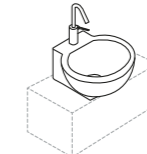
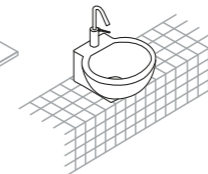
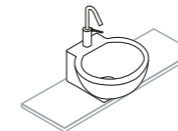

Y0HH 
460x460



YOU & ME

bidet sospeso monoforo

Bidet sospeso completo di fissaggio speciale. Installazione con staffa universale per sospesi.

vaso sospeso con sedile

Vaso sospeso completo di sedile frenato e fissaggio speciale. Installazione con staffa universale per sospesi.

bidet suspendu à un trou

Bidet suspendu avec kit de fixation spécial. Installation avec étrier universel pour éléments suspendus.

cuvette suspendu avec abattant

Cuvette suspendue dotée de abattant avec système frein de chute abattant et fixation spéciale. Installation avec étrier universel pour éléments suspendus.

one-hole wall hung bidet

One-hole wall hung bidet with special fixing included. Mounted using universal bracket for wall-hung elements.

wall hung wc with seat cover

Wall-hung WC with soft-close seat cover and special fixing element included. Mounted using universal bracket for wall-hung elements.

bidet suspendido de un orificio

Bidet suspendido completo de sistema de fijación especial. Instalación con estribo universal para artefactos suspendidos.

inodoro suspendido completo de asiento

Inodoro suspendido completo de asiento frenado y sistema de fijación especial. Instalación con estribo universal para artefactos suspendidos.

einlochbidet wandhängend

Wand-Bidet inklusive spezieller Halterung. Zur Montage mit universeller Wand-Halterung.

Hänge-Wc inklusive Sitz

Hänge-Wc inklusive soft close Sitz und spezieller Halterung. Montage mit universeller Wandhalterung.

подвесное биде с одним отверстием

Подвесное биде в комплекте со специальным крепежом. Установка с универсальным кронштейном для подвесной сантехники.

подвесной унитаз

Подвесной унитаз в комплекте с сиденьем с механизмом плавного опускания и специальным крепежом. Установка с универсальным кронштейном для подвесной сантехники.



375x505



375x505



Y0J9



Y0J7





YOU & ME

bidet monoforo filo muro

Bidet completo di fissaggi per installazione a filo muro.

vaso scarico universale filo muro con sedile

Vaso scarico universale completo di sedile, curva tecnica di scarico e fissaggio. Installazione a filo muro. Può essere abbinato alle cassette Monolith.

bidet à un trou ras du mur

Bidet avec kit de fixation pour installation au ras du mur.

cuvette vidange universelle ras du mur avec abattant

Cuvette vidange universelle avec abattant, tuyau coudé de vidange et fixation. Installation au ras du mur. Elle peut être associée aux chasses d'eau Monolith.

back-to-wall one hole bidet

Back-to-wall bidet, complete with fixing elements.

back to wall wc with universal outlet and with seat cover

WC with universal outlet, complete with seat cover, "s" trap convertor and fixing elements. Back-to-wall installation. Compatible with Monolith cisterns.

bidé de un orificio contra la pared

Bidé completo de sistema de fijación para instalación contra la pared.

inodoro con descarga universal contra la pared completo de asiento

Inodoro con descarga universal completo de asiento, curva técnica de descarga y sistema de fijación. Instalación contra la pared. Puede ser combinado con las cisternas Monolith.

einlochbidet zur Wand-Montage

Bidet inklusive Halterungen zur Wandmontage.

Wc mit Universal Abgang mit Sitz zur Wand-Montage

Tiefspüler mit Universal Abgang, komplett mit Sitz, technischer Ablauf-Kurve und Halterung. Zur Wandmontage. Kombinierbar mit WC-Kasten Monolith.

биде с одним отверстием

Биде в комплекте с крепежом для пристенной установки.

унитаз с универсальным сливом

Унитаз с универсальным сливом, в комплекте с сиденьем, сливным коленом и крепежом. Пристенная установка. Может комбинироваться со смывными бачками серии Monolith.



375x505



375x505

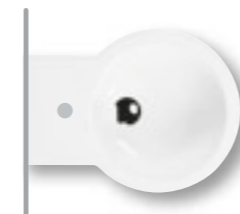

Y0H3



Y0H4

YOU & ME

Vaso d'angolo destro scarico universale con sedile

Vaso angolare destro per installazione a filo muro. Completo di sedile frenato, curva tecnica di scarico e fissaggi. Può essere abbinato alle cassette Monolith.

cuvette d'angle à droite universelle ras du mur avec abattant

Cuvette d'angle à droite pour installation au ras du mur. Avec abattant, tuyau coudé de vidange et kit de fixation. Elle peut être associée aux chasses d'eau Monolith.

right-hand corner WC universal outlet with seat cover

Right-hand corner WC for back-to-wall installation, complete with seat cover, "s" trap convertor and fixing elements. Compatible with Monolith cisterns

inodoro angular derecho con descarga universal completo de asiento

Inodoro angular derecho para instalar contra la pared. Completo de asiento, curva técnica de descarga y sistema de fijación. Puede ser combinado con las cisternas Monolith.

Eck-Wc rechts mit Universal Abgang mit Sitz

Eck-Wc rechts zur Vorwandinstallation. Komplett mit Sitz, technischer Abgang-Kurve und Halterungen. Kombinierbar mit Monolith Kästen.

угловой правосторонний унитаз

Угловой правосторонний унитаз для пристенной установки. В комплекте с сиденьем, сливным коленом и крепежом. Может комбинироваться со смывными бачками серии Monolith.

installazione installation



375x505



YOKE  





YOU & ME

+ MONOLITH

cassetta MONOLITH

Cassetta esterna in ceramica per installazione con vasi a filo muro. Meccanismo interno Geberit, doppio scarico 3/6 litri. Entrata acqua posteriore o laterale. Possibilità di installazione con scarico a terra variabile da 10 a 23 cm, oppure a parete.

chasse d'eau MONOLITH

Chasse d'eau extérieure en céramique pour installation avec cuvette au ras du mur. Mécanisme Geberit avec double touche avec possibilité de réglage à 3 ou 6 litres. Arrivée d'eau arrière ou latérale. Possibilité d'installation avec vidange au sol allant de 10 à 23 cm, ou bien murale.

MONOLITH Cistern

Ceramic cistern to be used with back-to-wall WCs. Geberit 3/6 litre inner mechanism with dual flush. Rear or side water inlet system with floor outlet. The floor outlet can vary from 10 to 23 cm.

cisterna MONOLITH

Cisterna externa de cerámica para instalación de inodoros contra la pared. Mecanismo interno Geberit, doble descarga 3/6 litros. Entrada de agua posterior o lateral. Posibilidad de instalación con descarga de tierra variable de 10 a 23 cm, o bien, de pared.

MONOLITH Kasten

Vorwand Kasten in Keramik zur Wandmontage. Innen Mechanismus Geberit, Doppelspülung 3/6 l. Wassereingang rückwärtig oder seitlich. Montagemöglichkeit mit senkrechtem oder waagrechtem Abgang, senkrechter Abgang variierbar von 10 bis 23 cm.

Бачок MONOLITH

Смывной керамический бачок для наружного монтажа к пристенным унитазам. Внутренний механизм Geberit, двойной слив 3-6 литров. Задний или боковой подвод воды. Возможна установка с регулируемым сливом в пол от 10 до 23 см или в стену.





370x635x900



Y0YN 
 Y0MK 
 Y0H4 



Y0YN 
 Y0MK 
 Y0KE 





SCULTURE EVENTO / SCULTURE

DESIGN DAL LAGO ASSOCIATI



SCULTURE EVENTO 65

LAVABO DA CENTROSTANZA FREESTANDING FREISTEHENDES WASCHBECKEN LAVABO CENTRE
PIECE LAVABO PARA CENTRO DE CUARTO DE BAÑO УМЫВАЛЬНИК ДЛЯ УСТАНОВКИ В
ЦЕНТРЕ ПОМЕЩЕНИЯ

Lavabo da centro stanza 65 cm scarico a terra o a parete, senza foro rubinetteria e troppopieno. Piletta speciale bianca a scarico libero. Sifone speciale estensibile scarico a terra e fissaggio speciale inclusi. Sifone estetico estensibile con prolunga per scarico a parete da ordinare separatamente. Colori disponibili: bianco, nero satinato, rosso lucido.

Floor or wall outlet freestanding 65 cm washbasin, without faucet hole and overflow. Special free outlet drain siphon with white cap. Special and adjustable plastic trap for floor outlet and special fixing included. Special aesthetic adjustable trap with extension wall pipe for wall outlet to be ordered separately. Available colours: white, satin black, glossy red.

Freistehendes Waschbecken 65 cm, Ablauf am Boden oder an der Wand, ohne Hahnloch und Überlauf. Besonderer Ausfluss mit freiem Ablauf. Besonderer verlängerbarer Siphon inkl. Bodenablauf und speziellen Befestigung. Ästhetischer verlängerbarer Siphon mit Verlängerung für Ablauf, Wandablauf muss separat bestellt werden. Verfügbare Farben: weiß, schwarz satiniert, rot glänzend.

Lavabo 65 cm centre pièce. Sans trous pour robinetterie et sans trop plein. Siphon spécial extensible pour sortie verticale et fixations inclus. Siphon esthétique extensible pour sortie horizontale à commander séparément. Couleurs disponibles : blanc, noir satiné et rouge brillant.

Lavabo para centro del cuarto de baño 65 cm desagüe en el suelo o pared, sin orificio para grifería ni rebosadero. Desagüe especial blanco con descarga libre. Sifón especial extensible desagüe en el suelo y fijación especial incluidos. Sifón estético extensible con prolongación para desagüe; desagüe de pared a pedir por separado. Colores disponibles: blanco, negro, satinado, rojo brillante.

Умывальник для установки в центре помещения, 65 см, слив в пол или в стену, без отверстия для смесителя и перелива. Специальная хозяйственная раковина белого цвета со свободным сливом. Специальный раздвижной сифон, слив в пол и специальный крепеж включены в комплект. Раздвижной сифон в эстетическом исполнении с удлинителем для слива в стену, который заказывается отдельно. Цвет: белый, черный сатиновый, красный блестящий.

installazione
installation

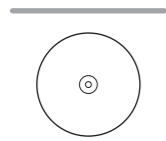

colori
colours

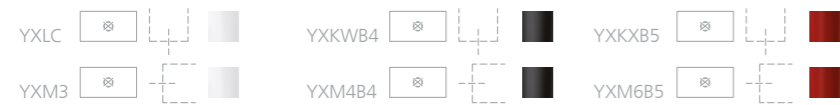

650x840h





SCULTURE EVENTO

bidet sospeso monoforo

Bidet sospeso da installare con staffa universale per sospesi. Completo di coprifissaggi in ceramica.

vaso sospeso con sedile

Vaso sospeso completo di sedile e coprifissaggi in ceramica. Da installare con staffa universale per sospesi.

bidet suspendu à un trou

Bidet suspendu à installer avec étrier universel pour éléments suspendus. Avec cache pour fixations en céramique.

cuvette suspendue avec abattant

Cuvette suspendue avec siège et cache pour fixations en céramique. À installer avec étrier universel pour éléments suspendus.

one hole wall hung bidet

Wall-hung bidet to be installed using universal bracket for wall-hung elements. Complete with ceramic fixing covers.

wall hung WC with seat cover

Wall-hung WC with seat cover and ceramic fixing covers. To be mounted using universal bracket for wall-hung elements.

bidé suspendido con un orificio

Bidé suspendido a instalar con estribo universal para artefactos suspendidos. Completo de cubre sistema de fijación de cerámica.

inodoro suspendido completo de asiento

Inodoro suspendido completo de asiento y cubre sistema de fijación de cerámica. A instalar con estribo universal para artefactos suspendidos.

Einloch-Bidet wandhängend

Hänge Bidet zur Installation mit universeller Wandhalterung. Inklusive Halterungsabdeckungen in Keramik.

Wand-Wc inklusive Sitz

Wand-Wc inklusive Sitz und Halterungsabdeckungen in Keramik. Zur Installation mit universeller Wandhalterung.

подвесное биде с одним отверстием

Подвесное биде устанавливается с универсальным кронштейном для подвесной сантехники. В комплекте с керамическими крепежными накладками.

подвесной унитаз

Подвесной унитаз в комплекте с сиденьем и керамическими крепежными накладками. Установка с универсальным кронштейном для подвесной сантехники.



SCULTURE EVENTO

PORTALE FURNITURE SCHRANK MEUBLE MUEBLE ТУМБА

Mobiletti portali in MDF verniciato, laccato lucido spazzolato bianco o nero, nelle misure 145x20 e 101,5x54 cm. Abbinabili a tutti i lavabi freestanding. Possono essere completati con una cassetiera 44x52 della stessa finitura.

Vanished, glazed brushind MDF furniture 145x20 or 101,5x54 cm. Available in white and black. Can combined with all freestanding washbasin and integrated with 44x52cm white or black drawers.

Schränke aus lackiertem MDF, glänzend lackiert, weiß oder schwarz gebürstet oder schwarz, in den Größen 145 x 20 und 101,5 x 54 cm. Passt zu allen freistehenden Waschbecken der Kollektion Sculture Evento. Sie können mit Schubladen 44 x 52 in der gleichen Oberflächenausführung versehen werden.

Élément en MDF peint, laqué brillant et brossé en blanc ou noir dans les dimensions 145x20 et 101,5x54 cm. En combinaison avec tous les lavabos freestanding de la collection Sculture Evento. A compléter avec desserte mobile en 44x52 de la même finition.

Mueble pórico de MDF barnizado, lacado, brillante cepillado blanco o negro, medidas 145x20 y 101,5x54 cm. Combinable con todos los lavabos freestanding Sculture Evento. Pueden completarse con una cajonera 44x52 en el mismo acabado.

Структура из окрашенного, лакированного, блестящего МДФ с щеточной обработкой поверхности, цвет белый или черный, размер 145x20 и 101,5x54 см. Может устанавливаться в сочетании с отдельно стоящими умывальниками серии Sculture Evento. Может быть укомплектована ящиками 44x52 с такой же отделкой.

YXM7

1450x200x660h



YXMU

1015x540x660h



YXM8

1450x200x660h



YXMV

1015x540x660h



YXMW

440x520x585h



YXMX

440x520x585h





SCULTURE 110

Lavabo integrale da 110 cm sospeso a muro, completo di fissaggi. Integrabile con colonna o semicolonna. Installabile anche in appoggio su piano.

Full 110 cm wall-hung washbasin, complete with fixing elements. Can be combined with full column or siphon cover. Can be surface-mounted.

Integrales Waschbecken 110 cm wandhängend, inklusive Halterungen. Ergänztbar mit Säule oder Halbsäule. Auch aufliegend montierbar.

Lavabo intégral de 110 cm suspendu au mur, avec kit de fixation. Intégrable avec colonne ou demi-colonne. Installable aussi avec bord de vasque apparent sur plan de toilette.

Lavabo integral de 110 cm suspendido en la pared, completo de sistema de fijación. Integrable con columna o semicolumna. Se puede instalar también apoyado sobre una encimera.

Подвесной настенный умывальник 110 см с одним отверстием в комплекте с крепежом. Может быть дополнен керамическим пьедесталом или полупьедесталом. Возможна также накладная установка.

installazione
installation

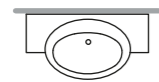

sospeso
wall hung

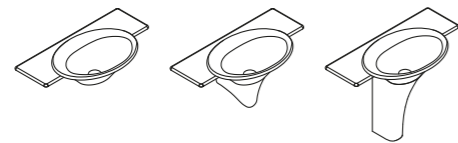

in appoggio
surface mounted

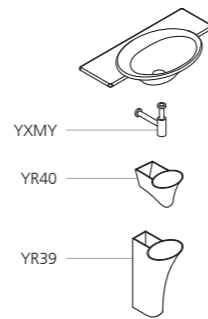
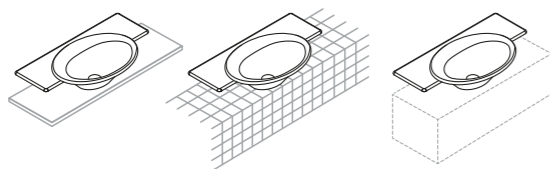

YR38 
1100x585





SCULTURE 77

Lavabo da 77 cm sospeso a muro, completo di fissaggi. Integrabile con colonna o semicolonna. Installabile anche in appoggio su piano.

77 cm wall-hung washbasin, complete with fixing elements. Can be combined with full column or siphon cover. Can be surface-mounted

Waschbecken 77 cm wandhängend, inklusive Halterungen. Ergänzierbar mit Säule oder Halbsäule. Auch aufliegend montierbar.

Lavabo de 77 cm suspendu au mur, avec kit de fixation. Intégrable avec colonne ou demi-colonne. Installable aussi avec bord de vasque apparent sur plan de toilette.

Lavabo de 77 cm suspendido en la pared, completo de sistema de fijación. Integrable con columna o semicolumna. Se puede instalar también apoyado sobre una encimera.

Подвесной настенный умывальник 77 см в комплекте с крепежом. Может быть дополнен керамическим пьедесталом или полупьедесталом. Возможна также накладная установка.

installazione
installation

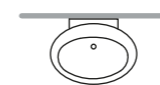

sospeso
wall hung

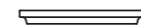

in appoggio
surface mounted

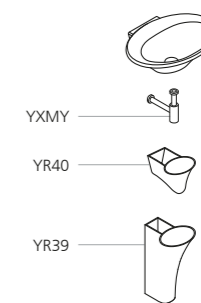
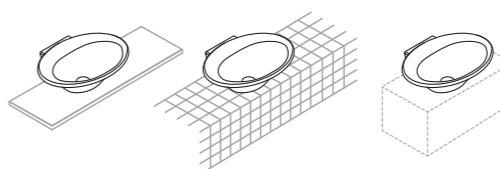

YXMY

YR40

YR39

YR37



770x585



SCULTURE 65

Lavabo da 65 cm sospeso a muro, completo di fissaggi. Integrabile con colonna o semicolonna. Installabile anche in appoggio su piano.

Lavabo de 65 cm suspendu au mur, avec kit de fixation. Intégrable avec colonne ou demi-colonne. Installable aussi avec bord de vasque apparent sur plan de toilette.

65 cm wall-hung washbasin, complete with fixing elements. Can be combined with full column or siphon cover. Can be surface-mounted.

Lavabo de 65 cm suspendido en la pared, completo de sistema de fijación. Integrable con columna o semicolumna. Se puede instalar también apoyado sobre una encimera.

Waschbecken 65 cm wandhängend, inklusive Halterungen. Ergänztbar mit Säule oder Halbsäule. Auch aufliegend montierbar.

Подвесной настенный умывальник 65 см с одним отверстием в комплекте с крепежом. Может быть дополнен керамическим пьедесталом или полупьедесталом. Возможна также накладная установка.

installazione
installation

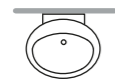

sospeso
wall hung



in appoggio
surface mounted

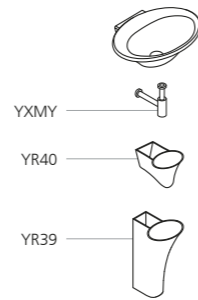
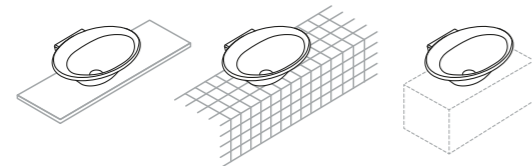

Y0LZ 
650x575





SCULTURE 90

Lavabo da 90 cm da installare in appoggio su piano. Completo di piletta a scarico libero con tappo speciale cromato. Utilizzabile con rubinetteria a parete o sul piano d'appoggio. Senza troppopieno.

Surface-mounted 90 cm washbasin, complete with free outlet drain siphon with special chrome-plated plug. Tap fittings may be installed on the wall or on the supporting top. No overflow.

Waschbecken 90 cm aufliegend. Inklusive Ausfluss mit freiem Ablauf und Spezial-Verschluss verchromt. Verwendbar mit Wand- oder Beckenarmaturen. Ohne Überlauf.

Lavabo de 90 cm à installer avec bord de vasque apparent sur plan de toilette. Avec tirette à vidage libre avec bouchon spécial chromé. Utilisable avec robinetterie murale ou sur plan de toilette. Sans trop-plein.

Lavabo de 90 cm a instalar sobre encimera. Completo de desagüe de descarga libre con tapón especial cromado. Utilizable con grifería de pared o encimera. Sin rebosadero.

Накладной умывальник 90 см. Укомплектован сливом свободного типа со специальной хромированной пробкой. Монтаж с настенными или в столешнице кранами. Без перелива.

installazione
installation

in appoggio
surface mounted

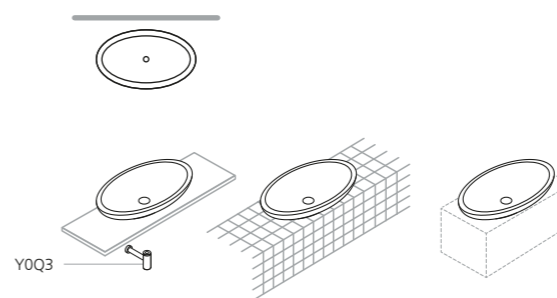

Y0MQ 
885x525



SCULTURE 70

Lavabo da 70 cm da installare in appoggio su piano. Completo di piletta a scarico libero con tappo speciale cromato. Senza troppopieno.

Surface-mounted 90 cm washbasin, complete with free outlet drain siphon with special chrome-plated plug. No overflow.

Waschbecken 70 cm aufliegend. Inklusive Ausfluss mit freiem Ablauf und Spezial-Verschluss verchromt. Ohne Überlauf.

Lavabo de 70 cm à installer avec bord de vasque apparent sur plan de toilette. Avec tirette à vidage libre avec bouchon spécial chromé. Sans trop-plein.

Lavabo de 70 cm a instalar sobre encimera. Completo de desagüe de descarga libre con tapón especial cromado. Sin rebosadero.

Накладной умывальник 70 см. Укомплектован сливом свободного типа со специальной хромированной пробкой. Без перелива.

installazione
installation

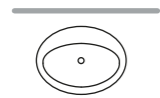

in appoggio
surface mounted

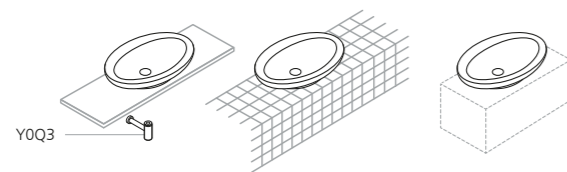

Y0MV 
690x525





SCULTURE 52

Lavabo da 52 cm da installare in appoggio su piano. Completo di piletta a scarico libero con tappo speciale cromato. Utilizzabile con rubinetteria a parete o sul piano d'appoggio. Senza troppopieno.

Surface-mounted 52 cm washbasin, complete with free outlet drain siphon with special chrome-plated plug. Tap fittings may be installed on the wall or on the supporting top. No overflow.

Waschbecken 52 cm aufliegend. Inklusive Ausfluss mit freiem Ablauf und Spezial-Verschluss verchromt. Verwendbar mit Wand- oder Beckenarmaturen. Ohne Überlauf.

Lavabo de 52 cm à installer avec bord de vasque apparent sur plan de toilette. Avec tirette à vidage libre avec bouchon spécial chromé. Utilisable avec robinetterie murale ou sur plan de toilette. Sans trop-plein.

Lavabo de 52 cm a instalar sobre encimera. Completo de desagüe de descarga libre con tapón especial cromado. Utilizable con grifería de pared o encimera. Sin rebosadero.

Накладной умывальник 52 см или на столешницу. Укомплектован сливом свободного типа со специальной хромированной пробкой. Монтаж с настенными или в столешнице кранами. Без перелива.

installazione
installation

in appoggio
surface mounted

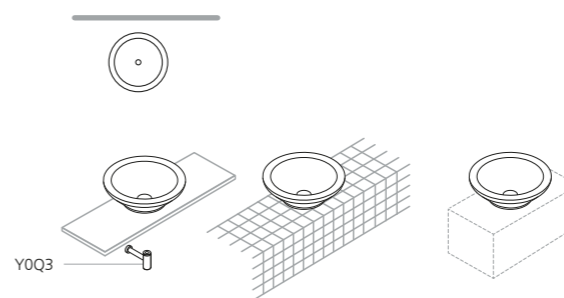

Y0MU 
520x520



SCULTURE

bidet sospeso monoforo

Bidet sospeso da installare con staffa universale per sospesi. Completo di coprifissaggi in ceramica.

vaso sospeso con sedile

Vaso sospeso completo di sedile e coprifissaggi in ceramica. Da installare con staffa universale per sospesi.

bidet suspendu à un trou

Bidet suspendu à installer avec étrier universel pour éléments suspendus. Avec cache pour fixations en céramique.

cuvette suspendue avec abattant

Cuvette suspendue avec siège et cache pour fixations en céramique. À installer avec étrier universel pour éléments suspendus.

one hole wall hung bidet

Wall-hung bidet to be installed using universal bracket for wall-hung elements. Complete with ceramic fixing covers.

wall hung WC with seat cover

Wall-hung WC with seat cover and ceramic fixing covers. To be mounted using universal bracket for wall-hung elements.

bidé suspendido con un orificio

Bidé suspendido a instalar con estribo universal para artefactos suspendidos. Completo de cubre sistema de fijación de cerámica.

inodoro suspendido completo de asiento

Inodoro suspendido completo de asiento y cubre sistema de fijación de cerámica. A instalar con estribo universal para artefactos suspendidos.

Einloch-Bidet wandhängend

Hänge Bidet zur Installierung mit universeller Wandhalterung. Inklusive Halterungsabdeckungen in Keramik.

Wand-Wc inklusive Sitz

Wand-Wc inklusive Sitz und Halterungsabdeckungen in Keramik. Zur Installierung mit universeller Wandhalterung.

подвесное биде с одним отверстием

Подвесное биде устанавливается с универсальным кронштейном для подвесной сантехники. В комплекте с керамическими крепежными накладками.

подвесной унитаз

Подвесной унитаз в комплекте с сиденьем и керамическими крепежными накладками. Установка с универсальным кронштейном для подвесной сантехники.



400x600



400x600



Y0BF



Y0LF
Y0RU





SCULTURE

bidet monoforo filo muro

Bidet per installazione a filo muro, completo di fissaggi.

vaso scarico universale filo muro con sedile

Vaso scarico universale completo di sedile, curva tecnica di scarico e fissaggio. Installazione a filo muro.

bidet à un trou au ras du mur

Bidet avec kit de fixation pour installation au ras du mur.

cuvette vidange universelle avec abattant

Cuvette vidange universelle avec abattant, tuyau coudé de vidange et fixation. Installation au ras du mur.

back to wall One hole bidet

Back-to-wall bidet, complete with fixing elements.

back to wall wc universal outlet with seat cover

WC with universal outlet, complete with seat cover, "s" trap convertor and fixing elements. Back-to-wall installation.

bidé de un orificio contra la pared

Bidé completo de sistema de fijación para instalación contra la pared.

inodoro con descarga universal completo di asiento

Inodoro con descarga universal completo de asiento, curva técnica de descarga y sistema de fijación. Instalación contra la pared.

einlochbidet zur Wand-Montage

Bidet inklusive Halterungen zur Wandmontage.

Wc mit Universal Abgang inklusive Sitz zur Wand-Montage

Tiefspüler mit Universal Abgang, komplett mit Sitz, technischer Ablauf-Kurve und Halterung. Zur Wandmontage.

биде с одним отверстием

Биде в комплекте с крепежом для пристенной установки.

унитаз с универсальным сливом

Унитаз с универсальным сливом, в комплекте с сиденьем, сливным коленом и крепежом. Пристенная установка.



400x600



400x600



YR42



YOLE
YORT

SCULTURE

vaso monoblocco con cassetta e sedile

Vaso scarico universale per installazione a filo muro, completo di sedile, curva tecnica di scarico e fissaggi. Da integrare con cassetta in ceramica entrata acqua laterale/alta, bassa oppure posteriore.

cuvette monobloc avec chasses d'eau et abattant

Cuvette à vidange universelle pour installation au ras du mur, avec abattant, tuyau coudé de vidange et fixations. À intégrer avec chasses d'eau en céramique à arrivée d'eau latérale/haute, basse ou postérieure.

one-piece WC with cistern and seat cover

Back-to-wall installation. Universal outlet. Complete with soft-close cover, "s" trap convertor and fixing elements. To be combined with ceramic cistern with water inlet at side/top, bottom or back.

inodoro monobloque con cisterna completo de asiento

Inodoro con descarga universal para instalar contra la pared, completo de asiento, curva técnica de descarga y sistema de fijación. A integrar con cisternas de cerámica con entrada de agua lateral/alta, baja o bien, posterior.

Kompaktes Klosett mit Spülkasten inclusive sitz

Kompaktes Klosett mit Universal Abgang zur Vorwandinstallation, inklusive Sitz, technischer Kurve und Halterungen. Ergänztbar mit Keramik-Spülkasten mit seitlichem Wassereingang, hoch, niedrig oder rückwärtigem Wassereingang.

моноблочный унитаз с Бачок

Унитаз с универсальным сливом для пристенной установки, включает сиденье, сливное колено и крепеж. Должен быть дополнен смывным керамическим бачком, боковой/верхний, нижний или задний подвод воды.



420x720x820



YOLG	WC	
YORV	WC	
YOFQ	3/6 L	
YOF5	3/6 L	
YOMM	3/6 L	





DOLCEVITA



DOLCEVITA 100

Lavabo consolle da 100 cm sospeso a muro, completo di fissaggi. Integrabile con colonna o coppia di gambe in ceramica.

Wall-hung 100 cm consolle washbasin, complete with fixing elements. Can be combined with a column or two porcelain legs.

Waschtisch 100 cm wandhängend, inklusive Halterungen. Ergänzzbar mit Säule oder Beinen in Keramik.

Lavabo console de 100 cm suspendu au mur, livré avec kit de fixation. Intégrable avec colonne ou deux pieds en céramique.

Lavabo tocador de 100 cm suspendido en la pared, completo de sistema de fijación. Integrable con columna o par de pies de cerámica.

Подвесной настенный консольный умывальник 100 см в комплекте с крепежом. Может быть дополнен керамическим пьедесталом или парой опор.

installazione
installation

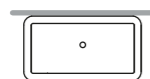

sospeso
wall hung

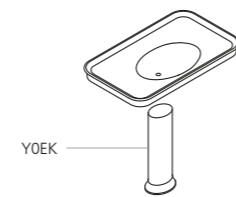
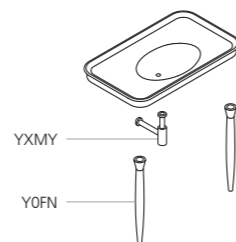
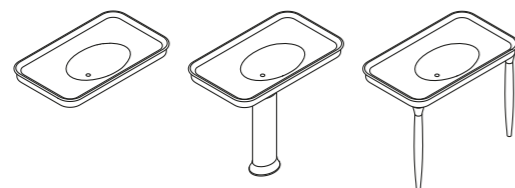

YOFO 
1000x550





DOLCEVITA R 75

Lavabo da 75 cm sospeso a muro, completo di fissaggi. Integrabile con colonna in ceramica.

75 cm wall-hung washbasin, complete with fixing elements. Can be combined with ceramic column.

Waschbecken 75 cm wandhängend, inklusive Halterungen. Ergänztbar mit Keramiksäule.

Lavabo de 75 cm suspendu au mur, livré avec kit de fixation. Intégrable avec colonne en céramique.

Lavabo de 75 cm suspendido en la pared, completo de sistema de fijación. Integrable con columna de cerámica.

Подвесной настенный умывальник 75 см в комплекте с крепежом. Может быть дополнен керамическим пьедесталом.

installazione
installation

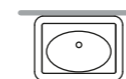

sospeso
wall hung

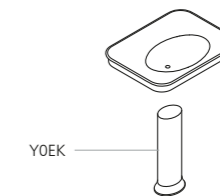
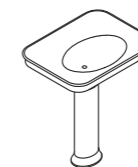

Y0EJ

750x550



DOLCEVITA O 75

Lavabo ovale da 75 cm sospeso a muro, completo di fissaggi. Integrabile con colonna in ceramica.

Oval 75 cm wall-hung washbasin, complete with fixing elements. Can be combined with ceramic column.

Ovales Waschbecken 75 cm wandhängend, inklusive Halterungen. Ergänztbar mit Keramiksäule.

Lavabo ovale de 75 cm suspendu au mur, livré avec kit de fixation. Intégrable avec colonne en céramique.

Lavabo ovalado de 75 cm suspendido en la pared, completo de sistema de fijación. Integrable con columna de cerámica.

Подвесной настенный овальный умывальник 75 см в комплекте с крепежом. Может быть дополнен керамическим пьедесталом.

installazione
installation

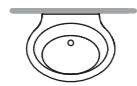

sospeso
wall hung

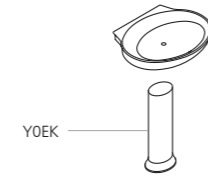
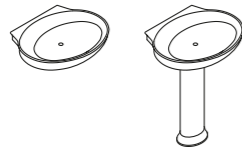

YOEW 
750x575





DOLCEVITA 70

Lavabo da 70 cm sospeso a muro, completo di fissaggi. Integrabile con colonna in ceramica.

70 cm wall-hung washbasin, complete with fixing elements. Can be combined with ceramic column.

Waschbecken 70 cm wandhängend, inklusive Halterungen. Ergänztbar mit Keramiksäule.

Lavabo de 70 cm suspendu au mur, livré avec kit de fixation. Intégrable avec colonne en céramique.

Lavabo de 70 cm suspendido en la pared, completo de sistema de fijación. Integrable con columna de cerámica.

Подвесной настенный умывальник 70 см в комплекте с крепежом. Может быть дополнен керамическим пьедесталом.

installazione
installation



sospeso
wall hung

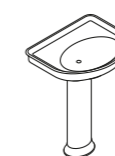

YXMY

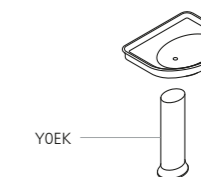

YOEK

YOEX 

750x550



DOLCEVITA 650x480

Lavabo 65 cm da incasso. Installazione sopra il piano del mobile.

65 cm built-in washbasin, mounted on the countertop.

Einbau-Waschbecken 65 cm. Zur Installation auf Möbel-Ebene.

Lavabo 65 cm à vasque intégrée. Installation à bord de vasque apparent sur le plan de toilette du meuble.

Lavabo de 65 cm a empotrar. Instalación sobre la encimera del mueble.

Встроенный умывальник 65 см. Устанавливается на плоскость тумбы.

installazione
installation

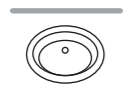

incasso
built in



YXMY

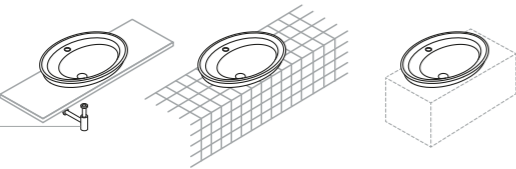

YOPL 

650x480





DOLCEVITA

bidet monoforo

Bidet con erogazione acqua dal rubinetto, completo di fissaggi.

bidet triforo

Bidet con erogazione acqua dalla ceramica, completo di fissaggi.

vaso con sedile

Vaso scarico a parete o a pavimento. Completo di sedile in legno e poliestere e fissaggi.

bidet à un trou

Bidet avec débit d'eau du robinet, livré avec kit de fixation.

bidet à trois trous

Bidet avec débit d'eau de la céramique, livré avec kit de fixation.

cuvette avec abattant

Cuvette avec vidange murale ou au sol. Avec abattant en bois ou polyester et kit de fixation.

one-hole bidet

One-hole bidet with water delivery from tap, complete with fixing elements.

three-hole bidet

Three-hole bidet with water delivery from bowl, complete with fixing elements.

WC with seat cover

WC with wall or floor outlet. Complete with wood or polyester seat cover and fixing elements.

bidé con un orificio

Bidé con Salida de agua del grifo, completo de sistema de fijación.

bidé con tres orificios

Bidé con salida de agua de la cerámica, completo de sistema de fijación.

inodoro completo de asiento

Inodoro con descarga, de pared o pavimento. Completo de asiento y sistema de fijación.

Einloch-Bidet

Bidet mit Wasserspende aus dem Wasserhahn, inklusive Halterungen.

Dreiloch-Bidet

Bidet mit Wasserspende aus der Schüssel, inklusive Halterungen.

Wc inklusive Sitz

Wc mit Wand-oder Bodenspülung. Inklusive Sitz und Halterungen.

Биде с одним отверстием

Биде с подачей воды из крана, в комплекте с крепежом.

биде с тремя отверстиями

Биде с внутренней подачей воды, в комплекте с крепежом.

унитаз

Унитаз со сливом в стену или в пол, в комплекте с сиденьем и крепежом.



370x595



370x590



Y0ET 
Y0EU 



Y0H9 
Y0HA 

DOLCEVITA

vaso con cassetta a zaino e sedile

Vaso scarico a parete o a pavimento, completo di sedile e fissaggi, con cassetta a zaino in ceramica. Entrata acqua bassa con meccanismo doppio scarico 3/6 litri.

cuvette avec chasse d'eau extérieure et abattant

Cuvette avec vidange murale ou au sol. Avec abattant et kit de fixation, avec chasse d'eau extérieure en céramique. Arrivée d'eau basse avec mécanisme à double touche avec possibilité de réglage à 3 ou 6 litres.

WC with low-level cistern and seat cover

WC with wall or floor outlet and low level ceramic cistern, complete with wood or polyester seat cover and fixing elements. Double-flush (3/6 litres) mechanism and water intake at bottom.

inodoro con cisterna de mochila y asiento

Inodoro con descarga de pared o pavimento, completo de asiento de madera o de poliéster y sistema de fijación, con cisterna de mochila de cerámica. Entrada de agua baja con mecanismo de doble descarga 3/6 litros.

Wc mit Aufputzspülkasten und Sitz

Wc mit Wand-oder Bodenspülung, inklusive Sitz und Halterungen, Aufputzspülkasten in Keramik. Wassereingang tief mit Doppelspül Mechanismus 3/6 l.

унитаз с заплечным бачком

Унитаз со сливом в стену или в пол, в комплекте с сиденьем, крепежом и с заплечным бачком из керамики. Нижний подвод воды с механизмом двойного слива 3-6 литров.



370x710x1005



- Y0H9  
- Y0HA  
- Y0U3 





pro come

progetto

pro

come progetto

soluzioni modulari e flessibili per il mondo professionale

MODULAR AND FLEXIBLE SOLUTIONS FOR THE PROFESSIONAL WORLD
MODULARE, FLEXIBLE LÖSUNGEN FÜR DIE WELT DER PROFESSIONISTEN
SOLUTIONS MODULAIRES ET FLEXIBLES POUR LE MONDE PROFESSIONNEL
SOLUCIONES MODULARES Y FLEXIBLES PARA EL MUNDO PROFESIONAL
МОДУЛЬНЫЕ И ГИБКИЕ РЕШЕНИЯ ДЛЯ ПРОФЕССИОНАЛЬНОГО МИРА

Un'ampia gamma di soluzioni modulari e componibili risponde alle rinnovate esigenze del bagno contemporaneo. "Pro come progetto" raccoglie una serie di sanitari e complementi che si adattano alle diverse esigenze del mondo della progettazione con una sintesi di prodotti essenziali ed ergonomici all'insegna della massima funzionalità.

A wide range of modular and fitted solutions respond to the changed requirements of the modern bathroom. "Pro as project" includes a series of sanitary fittings and accessories that adapt to the various requirements of the design world with a synthesis of essential and ergonomic products designed to offer maximum functionality.

Eine breite Palette an modularen, zusammensetzbaren Lösungen wird den neuen Ansprüchen des zeitgenössischen Badezimmers gerecht. „Pro wie Projekt“ umfasst eine Reihe an sanitären Einrichtungen und Zusätzen, die sich an die verschiedenen Bedürfnisse der Welt der Planung mit einer Kombination an essentiellen, ergonomischen Produkten im Zeichen der größtmöglichen Zweckmäßigkeit anpassen.

Une vaste gamme de solutions modulaires et composables répond aux nouvelles exigences de la salle de bains contemporaine. « Pro comme Projet » rassemble une série de sanitaires et de compléments qui s'adaptent aux différentes exigences du monde de la conception à travers une synthèse de produits essentiels et ergonomiques sous le signe de la fonctionnalité maximale.

Una amplia gama de soluciones modulares responde a las renovadas exigencias del baño contemporáneo. "Pro como proyecto" recoge una serie de sanitarios y complementos que se adaptan a las distintas exigencias del mundo del diseño con una síntesis de productos sobrios y ergonómicos bajo el lema de la máxima funcionalidad.

Широкая гамма модульных и сборных решений отвечает новым требованиям к современной ванной комнате. "Про как проект" объединил в себе серию сантехники и аксессуаров, которые удовлетворяют различные требования мира проектирования, предлагая строгие и эргономичные изделия под знаком максимальной функциональности.



LAVABI SOSPESI O DA MOBILE

SUSPENDED OR CABINET WASHBASINS HÄNGE- ODER MÖBELWASCHBECKEN LAVABOS SUSPENDUS OU SUR MEUBLE
LAVABOS SUSPENDIDOS O DE MUEBLE РАКОВИНЫ ПОДВЕСНЫЕ ИЛИ ВСТРАИВАЕМЫЕ В МЕБЕЛЬ



SHIRLEY 1205x495 SHIRLEY 1055x495 SHIRLEY 860x500 SHIRLEY 750x495 SHIRLEY 560x445

SOPHIE 1250x500 SOPHIE 1200x500 SOPHIE 1050x500 SOPHIE 950x500 SOPHIE 860x500 SOPHIE 750x495 SOPHIE 560x450

SUSAN 1255x500 SUSAN 1105x500 SUSAN 950x500 SUSAN 950x500 sx / lh SUSAN 950x500 dx / rh SUSAN 750x500 SUSAN 650x500

ERIKA pro 1200x450 ERIKA pro 1000x450 ERIKA pro 800x450 ERIKA pro 650x450 ERIKA pro 600x450 ERIKA pro 550x400 ERIKA pro 450x380

LAVABI SOSPESI CON COLONNA O SEMICOLONNA

WALL-HUNG WASHBASINS WITH FULL COLUMN OR SIPHON COVER HÄNGEWASCHBECKEN MIT STANDSÄULE ODER HALBSÄULE LAVABOS SUSPENDUS AVEC COLONNE OU DEMI-COLONNE LAVABOS SUSPENDIDOS CON PEDESTAL O SEMIPEDESTAL РАКОВИНЫ ПОДВЕСНЫЕ С КОЛОННОЙ ИЛИ ПОЛУКОЛОННОЙ

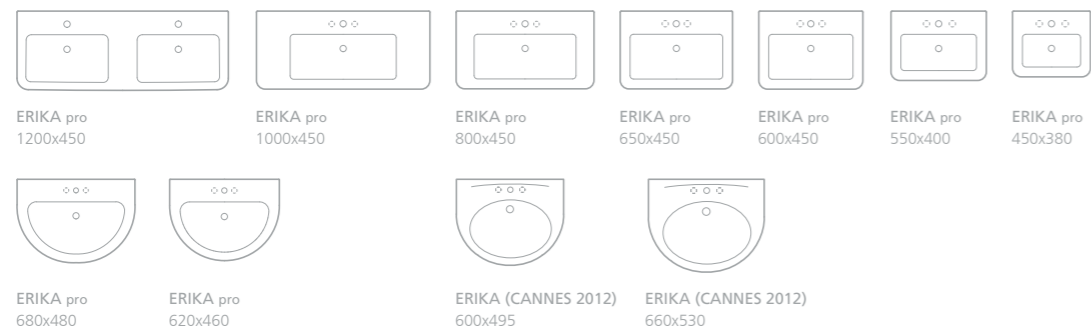

ERIKA pro 1200x450 ERIKA pro 1000x450 ERIKA pro 800x450 ERIKA pro 650x450 ERIKA pro 600x450 ERIKA pro 550x400 ERIKA pro 450x380

ERIKA pro 680x480 ERIKA pro 620x460 ERIKA (CANNES 2012) 600x495 ERIKA (CANNES 2012) 660x530

LAVABI INCASSO / SEMINCASSO

BUILT IN WASHBASINS / HALF BUILT IN EINBAUWASCHBECKEN / HALBEINBAU LAVABOS À VASQUE INTÉGRÉE / SEMI ENCASTRÉ LAVABOS EMPOTRADOS / SEMIEMPOTRADOS РАКОВИНЫ ВСТРАИВАЕМЫЕ / ПОЛУВСТРАИВАЕМЫЙ

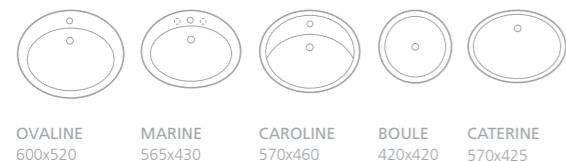

OVALINE 600x520 MARINE 565x430 CAROLINE 570x460 BOULE 420x420 CATERINE 570x425



SEMINCASSO 650x515 HAPPY HOUR 09:30 480x480 HAPPY HOUR 07:15 440x440 HAPPY HOUR 11:15 500x380

LAVAMANI E SPECIALI

HAND-WASH AND SPECIAL BASINS HANDWASCHBECKEN UND SPEZIALPRODUKTE LAVE-MAINS ET ACCESSOIRES SPÉCIAUX LAVAMANOS Y ESPECIALES РУКОМОЙНИКИ И КОМПЛЕКТУЮЩИЕ



DAYTIME 450x378 ERIKA PRO 450x380 SELECTA 450x375 NINA 460x340 DINO 505x220 AUTONOMY 680x600

LAVABI A CANALE 1200x450 905x450 LAVATOIO 610x500 FIFTY.LP 600x500 SIXTY.LP 600x600 LAVATOIO PILOZZO 380x420

PIATTI DOCCIA

SHOWER TRAYS DUSCHWANNEN RECEVEURS DE DOUCHE PLATOS DE DUCHA ДУШЕВЫЕ ПОДДОНЫ

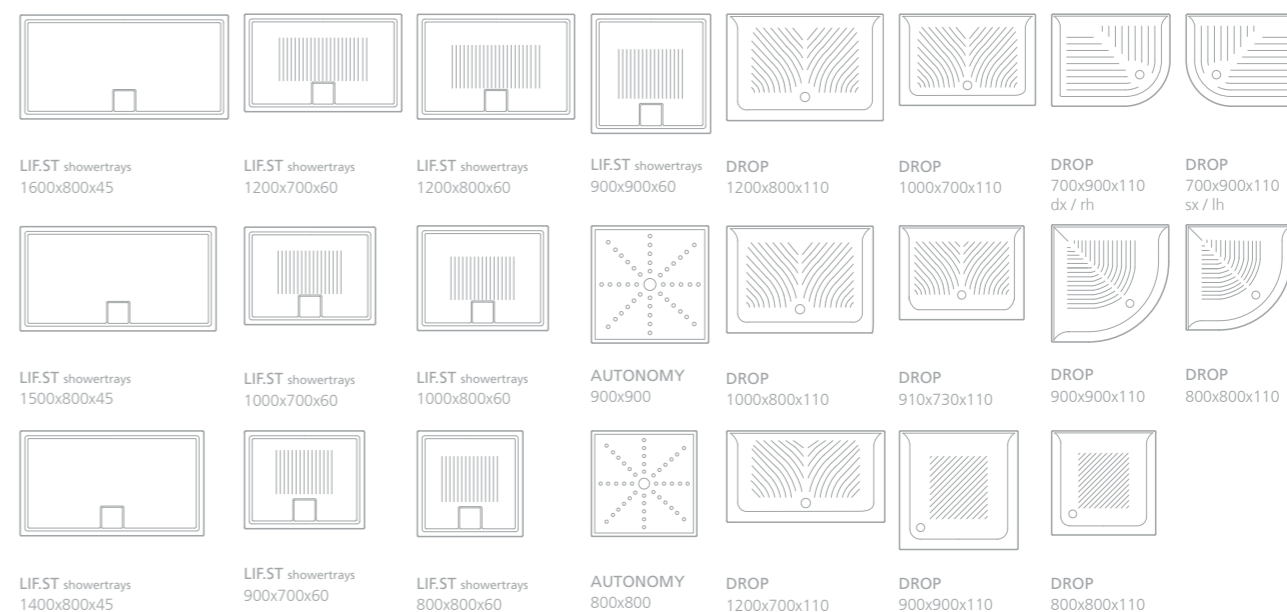

LIF.ST showertrays 1600x800x45 LIF.ST showertrays 1200x700x60 LIF.ST showertrays 1200x800x60 LIF.ST showertrays 900x900x60 DROP 1200x800x110 DROP 1000x700x110 DROP 700x900x110 dx / rh DROP 700x900x110 sx / lh LIF.ST showertrays 1500x800x45 LIF.ST showertrays 1000x700x60 LIF.ST showertrays 1000x800x60 AUTONOMY 900x900 DROP 1000x800x110 DROP 910x730x110 DROP 900x900x110 DROP 800x800x110 LIF.ST showertrays 1400x800x45 LIF.ST showertrays 900x700x60 LIF.ST showertrays 800x800x60 AUTONOMY 800x800 DROP 1200x700x110 DROP 900x900x110 DROP 800x800x110

ORINATOI / TURCHE / SPECIALI

URINALS / SQUATTING WC / SPECIAL BASINS URINALE / TÜRKISCHE TOILETTE / SPEZIALPRODUKTE URINOIRS / SIÈGE À LA TURQUE / SPÉCIAUX URINARIOS / INODORO A LA TURCA / ESPECIALES ПИССУАРЫ / ЧАША ГЕНУЯ / КОМПЛЕКТУЮЩИЕ

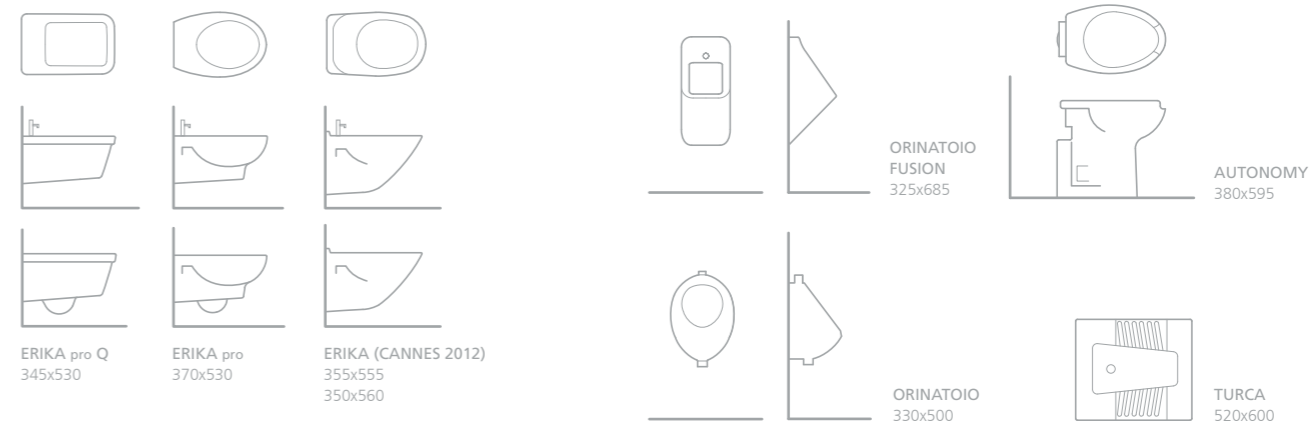

ORINATOIO FUSION 325x685 AUTONOMY 380x595

ORINATOIO 330x500 TURCA 520x600

VASI E BIDET A TERRA / VASI CON CASSETTA / MONOLITH

FLOOR-MOUNTED WCS AND BIDETS / WCS WITH CISTERNS / MONOLITH STANDKLOSETTS UND -BIDETS / KLOSETTS MIT SPÜLKASTEN / MONOLITH CUVETTES ET BIDETS AU SOL / CUVETTES AVEC CHASSE D'EAU / MONOLITH INODOROS Y BIDÉS DE SUELO / INODOROS CON CISTERNA / MONOLITH НАПОЛЬНЫЕ УНИТАЗЫ И БИДЕ / УНИТАЗЫ С БАЧКОМ ДЛЯ СЛИВА / MONOLITH

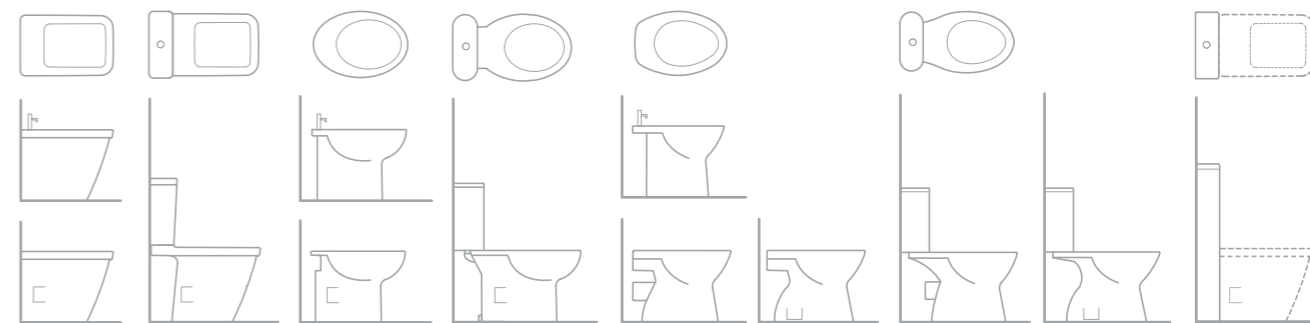

ERIKA pro Q 345x530 ERIKA pro Q 370x625 ERIKA pro 370x530 ERIKA pro 370x675 CANNES (CANNES 2012) 360x520 CANNES (CANNES 2012) 370x665 CANNES (CANNES 2012) 370x670 (ERIKA pro Q, DAYTIME, DAYTIME EVO, YOU&ME, FUSION, NIDO) + MONOLITH 370x130x900



SUSAN



SOPHIE

LAVABI SOSPESI O DA MOBILE

SUSPENDED OR CABINET WASHBASINS HÄNGE- ODER MÖBELWASCHBECKEN LAVABOS SUSPENDUS OU SUR MEUBLE
LAVABOS SUSPENDIDOS O DE MUEBLE РАКОВИНЫ ПОДВЕСНЫЕ ИЛИ ВСТРАИВАЕМЫЕ В МЕБЕЛЬ

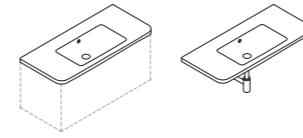

Lavabi integrali per installazione sospesa a parete con sifone a vista oppure su mobile dedicato.

Complete washbasins with design siphon for wall or cabinet installation.

Vollständige Waschbecken für die hängende Installation an der Wand mit sichtbarem Siphon oder auf einem entsprechenden Möbel.

Lavabos complets pour installation suspendue au mur avec siphon visible ou bien montés sur un meuble prévu à cet effet.

Lavabos integrales para instalación suspendida de pared con sifón visto o sobre mueble dedicado.

Раковины цельные подвесные для пристенного монтажа с открытым сифоном или встраиваемые в специальную мебель.



Y0HP_SUSAN
1255x500



Y0Q5_SOPHIE
1250x500

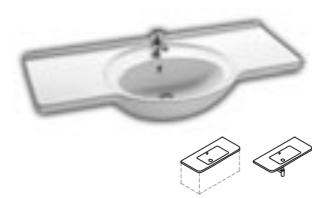

YU64_SHIRLEY
1205x495



YXJC_ERIKA PRO
1200x450



Y0HM_SUSAN
1105x500

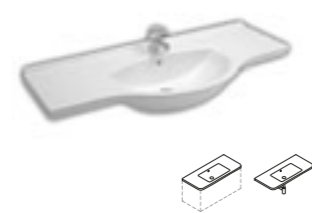

Y0AN_SOPHIE
860x500

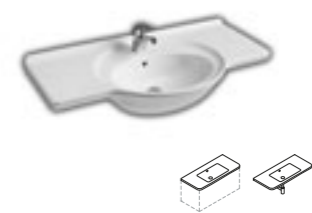

YQ48_SHIRLEY
1055x495



YXEA_ERIKA PRO
1000x450

Y0HR_SUSAN
750x500

Y0FG_SOPHIE
750x495

Y0D5_SHIRLEY
750x495

YXE9_ERIKA PRO
800x450

Y0HI_SUSAN
950x500

Y0HC_SOPHIE
950x500

Y0BQ_SHIRLEY
865x500



Y0JU_SUSAN
950x500 dx/rh



Y0IS_SUSAN
950x500 sx/lh



Y0HG_SOPHIE
560x450



Y0BI_SHIRLEY
560x445

YXBE_ERIKA PRO
650x450

YXBI_ERIKA PRO
550x400

YXBH_ERIKA PRO
600x450

YXBJ_ERIKA PRO
450x380



SOPHIE 95

SOPHIE

125 doppio



120



86



105



75



95



56



ERIKA pro 65

ERIKA pro

120 doppio



100



60



80



55



65



45



SHIRLEY 86

SHIRLEY

120



75



105



56



86



SUSAN 65

SUSAN

125 doppio



95



110



95 dx / rh



65



95 sx / lh



75



ACCESSORI ACCESSORIES_SOPHIE/SHIRLEY



staffe reggi barra
bracket
YOPV



staffe reggi mensola
shelf bracket
YOPZ



sifone
siphon
YXMY



barra portasciugamano
towel rail
SOPHIE: SHIRLEY:
120_YOPR 120_YOPR
105_YOPS 105_YOPS
95_YOPT 86_YOPU
86_YOPU 75_YOQO
75_YOQO



mensola legno
wood shelf
SOPHIE: SHIRLEY:
120_YOPY 120_YOPY
105_YOPK 105_YOPK
95_YOPW 86_YOPJ
86_YOPJ 75_YOPX
75_YOPX

ACCESSORI ACCESSORIES_SUSAN



staffe reggi barra
bracket
YOK6



barra portasciugamano
towel rail
125_YOK7
110_YOK8
95_YOK9
75_YOKA
65_YOKB



sifone
siphon
YXMY

ACCESSORI ACCESSORIES_ERIKA pro



sifone
siphon
YXMY



LAVABI SOSPESI CON COLONNA O SEMICOLONNA

WALL-HUNG WASHBASINS WITH FULL COLUMN OR SIPHON COVER HÄNGEWASCHBECKEN MIT STANDSÄULE ODER HALBSÄULE
 LAVABOS SUSPENDUS AVEC COLONNE OU DEMI-COLONNE LAVABOS SUSPENDIDOS CON PEDESTAL O SEMIPEDESTAL
 РАКОВИНЫ ПОДВЕСНЫЕ С КОЛОННОЙ ИЛИ ПОЛУКОЛОННОЙ

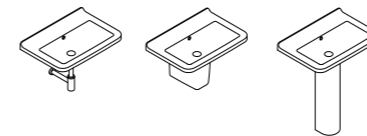

Lavabi per installazione sospesa a parete con colonna, semicolonna oppure con sifone a vista.

Wall-hung washbasins with full column, siphon cover or design siphon.

Waschbecken für die hängende Installation an der Wand mit Standsäule, Halbsäule oder mit sichtbarem Siphon.

Lavabos pour installation suspendue au mur avec colonne, demi-colonne ou bien avec siphon visible.

Lavabos para instalación suspendida de pared con pedestal, semipeDESTAL o sifón visto.

Раковины подвесные для пристенного монтажа с колонной, полуколонной или открытым сифоном.



YXJC_ERIKA PRO
1200x450



YXEA_ERIKA PRO
1000x450



YXE9_ERIKA PRO
800x450



YXBE_ERIKA PRO
650x450



YXBH_ERIKA PRO
600x450



YXBI_ERIKA PRO
550x400



YXBJ_ERIKA PRO
450x380



YXJD_ERIKA PRO
680x480



YOT8_ERIKA (CANNES 2012)
660x530



YXJE_ERIKA PRO
620x460

YOT9_ERIKA (CANNES 2012)
600x495

LAVABI SOSPESI CON COLONNA O SEMICOLONNA



ERIKA pro 45

ERIKA pro

120 doppio



100



60



80



55



65



45



68



62



ERIKA pro 62

CANNES 2012

66



60



CANNES 2012 (ERIKA 60)



ERIKA pro 65



ERIKA pro 55



ERIKA pro 100



HAPPY HOUR 11:15



HAPPY HOUR 09:30

LAVABI INCASSO / SEMINCASSO

BUILT IN WASHBASINS / HALF BUILT IN EINBAUWASCHBECKEN / HALBEINBAU LAVABOS À VASQUE INTÉGRÉE / SEMI ENCASTRÉ
LAVABOS EMPOTRADOS / SEMIEMPOTRADOS РАКОВИНЫ ВСТРАИВАЕМЫЕ / ПОЛУВСТРАИВАЕМЫЙ



Lavabi d'arredo per l'installazione ad incasso sopra o sotto il piano, oppure a semincasso.

Design washbasins for the installation built in, half built in or under the top.

Einrichtungswaschbecken für den Einbau über oder unter der Fläche, und Halbeinbau montage.

Lavabos d'ameublement pour installation à bord de vasque apparent ou intégré, ou semi encastré.

Lavabos decorativos para instalación empotrada encima o debajo de la encimera, o semi empotrado.

Раковины, встраиваемые в столешницу или под столешницу, или полувстраиваемый.



Y671_OVALINE
600x520



Y651_CATERINE
570x425



Y791_SEMINCASSO
650x515



Y751_MARINE
560x435



YXSP_HAPPY HOUR 07:15
440x440



Y0M8_HAPPY HOUR 09:30
480x480



Y631_CAROLINE
570x460



YXSQ_HAPPY HOUR 11:15
500x380



Y691_BOULE
420x420

LAVABI INCASSO / SEMINCASSO



OVALINE (INCASSO)



MARINE (INCASSO)



CATERINE

CATERINE (INCASSO SOTTOPIANO)



CAROLINE (INCASSO)



HAPPY HOUR 07:15

HAPPY HOUR 07:15 (INCASSO SOTTOPIANO)



BOULE (INCASSO)



SEMINCASSO

HAPPY HOUR 09:30 (SEMINCASSO)



SEMINCASSO





ERIKA pro 45



SIXTY.LP 60x60

LAVAMANI E SPECIALI

HAND-WASH AND SPECIAL BASINS HANDWASCHBECKEN UND SPEZIALPRODUKTE LAVE-MAINS ET ACCESSOIRES SPÉCIAUX
LAVAMANOS Y ESPECIALES РУКОМОЙНИКИ И КОМПЛЕКТУЮЩИЕ

Lavamani sospesi a parete per piccoli spazi e prodotti speciali complementari per il bagno.

Wall-hung hand wash basins for small spaces and special accessories for the bathroom.

Wand hängende Handwaschbecken für kleine Räume und Spezialprodukte zur Ergänzung des Badezimmers.

Lave-mains suspendus au mur, idéal pour espaces restreints et accessoires spéciaux pour la salle de bains.

Lavamanos suspendidos de pared para pequeños espacios y productos especiales complementarios para el cuarto de baño.

Подвесные раковины для пристенного монтажа для малогабаритных помещений и комплектующие для ванной комнаты.



YXBM_DAYTIME
450x378



YN05_LAVABO A CANALE YN04_LAVABO A CANALE
1200x450 905x450



YXBJ_ERIKA PRO
450x380



YXMC_SIXTY.LP
600x600



YD83_SELECTA
450x375



YXMA_FIFTY.LP
600x500



Y891_NINA
460x340



YN00_LAVATOIO
610x500



Y931_DINO
505x220



YN02_LAVATOIO PILOZZO
380x420

LAVAMANI



ERIKA pro 45

ERIKA pro

45



DAYTIME 45

DAYTIME

45



SELECTA

45



NINA

46



DINO

50



SPECIALI



SIXTY.LP

LAVAPANNI

FIFTY.LP 60x50



SIXTY.LP 60x60



LAVATOI

61x50



PILOZZO 38x42



LAVABO A CANALE 120x45



LAVABO A CANALE 90,5x45





ERIKA pro



CANNES 2012 (ERIKA)

VASI E BIDET SOSPESI

WALL-HUNG WCS AND BIDETS HÄNGEKLOSETTS UND -BIDETS CUVETTES ET BIDETS SUSPENDUS
INODOROS Y BIDÉS SUSPENDIDOS УНИТАЗЫ И БИДЕ ПОДВЕСНЫЕ

Vasi e bidet per installazione sospesi a parete con apposite staffe da incassare. Semplice montaggio e facilità di pulizia dello spazio sottostante.

Wall-hung WCs and bidets with special built-in brackets. Simple installation and easy to clean the underlying area.

Klosetts und Bidets für die hängende Installation an der Wand mit entsprechenden Bügel zum Einbauen. Einfache Montage und leichte Reinigung des umliegenden Raums.

Cuvettes et bidets pour installation suspendue au mur au moyen d'étriers spécialement conçus pour être murés. Montage simple et espace sous-jacent facile à nettoyer.

Inodoros y bidés para instalación suspendida de pared con elementos especiales de fijación a empotrar. Sencillo montaje y fácil limpieza del espacio situado debajo.

Чаши унитаза и биде подвесные для пристенного монтажа с соответствующей системой инсталляции. Просты в установке и облегчают уборку пола.



YXHW_ERIKA pro Q
345x530



YXJQ_ERIKA pro Q
345x530



YXBT_ERIKA pro
370x530



YXBS_ERIKA pro
370x530



YOT6_ERIKA (CANNES 2012)
355x555



YORH_ERIKA (CANNES 2012)
350x560

VASI E BIDET SOSPESI



ERIKA pro Q

ERIKA pro Q



BIDET

WC



ERIKA pro

ERIKA pro



BIDET

WC



CANNES 2012 (ERIKA)

CANNES 2012



BIDET

WC



ERIKA pro



ERIKA pro Q



CANNES 2012 (CANNES)

VASI E BIDET A TERRA / VASI CON CASSETTA

FLOOR-MOUNTED WCS AND BIDETS/ WCS WITH CISTERNS STANDKLOSETTS UND -BIDETS / KLOSETTS MIT SPÜLKASTEN CUVETTES ET BIDETS AU SOL / CUVETTES AVEC CHASSE D'EAU INODOROS Y BIDÉS DE SUELO / INODOROS CON CISTERNA НАПОЛЬНЫЕ УНИТАЗЫ И БИДЕ / УНИТАЗЫ С БАЧКОМ ДЛЯ СЛИВА

Vasi e bidet a terra per installazione a seconda del modello, distanti dal muro oppure a filo muro. Vasi monoblocco con cassetta esterna in ceramica, anche con meccanismo doppio scarico 3/6 litri preinstallato.

Cuvettes et bidets au sol pour installation espacée ou bien au ras du mur, selon le modèle. Cuvettes monobloc avec chasse d'eau extérieure en céramique, y compris avec mécanisme double touche avec réservoir de chasse 3 ou 6 litres préinstallé.

Floor-mounted WCs and bidets to be installed according to the model, away from or against the wall. Single-piece WCs with external ceramic cisterns as well as with pre-installed 3/6l dual-flush mechanisms.

Inodoros y bidés de suelo para instalación según modelo, separados o a ras de la pared. Inodoros monobloque con cisterna exterior de cerámica, también con mecanismo preinstalado de doble descarga de 3/6 litros.

Standklosetts und -bidets für die Installation mit oder ohne Abstand von der Wand, je nach Modell. Kompakte Klosetts mit externem Keramikspülkasten, auch mit bereits installiertem doppeltem Spülmechanismus für 3/6 Liter.

Напольные чаши унитаза и биде для пристенного монтажа или на расстоянии от стены в зависимости от модели. Унитазы моноблок с внешним керамическим сливным бачком, с механизмом двойного слива, объем 3/6 л, или без механизма.



YXHU_ERIKA pro Q
345x530



YXBP_ERIKA pro
370x535



(CANNES 2012)
YXDF_CANNES
365x520



YXHY_ERIKA pro Q
345x530



YXBR_ERIKA pro
370x530



(CANNES 2012)
YXDJ_CANNES
360x520



YXDB_CANNES
360x520



YXJ2_ERIKA pro Q WC
370x625x805



YXBO_ERIKA pro WC
370x675x778



(CANNES 2012)
YXDG_CANNES WC
368x670x783



YXGR_SQUARE 3/6 L YXGT_SQUARE 3/6 L

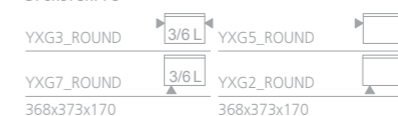

YXG3_ROUND 3/6 L YXG5_ROUND 3/6 L YXG7_ROUND 3/6 L YXG2_ROUND 3/6 L

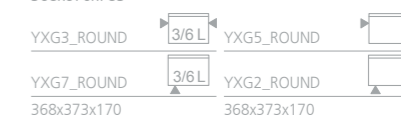

YXG3_ROUND 3/6 L YXG5_ROUND 3/6 L YXG7_ROUND 3/6 L YXG2_ROUND 3/6 L

VASI E BIDET A TERRA



ERIKA pro Q



BIDET

WC

ERIKA pro Q



ERIKA pro



BIDET

WC

ERIKA pro



CANNES 2012



BIDET

WC

CANNES 2012 (CANNES)

VASI CON CASSETTA



ERIKA pro Q



ERIKA pro Q



ERIKA pro



ERIKA pro



CANNES 2012



CANNES 2012 (CANNES)



MONOLITH + VASO ERIKA pro Q

CASSETTA MONOLITH

MONOLITH CISTERN MONOLITH KASTEN CHASSE D'EAU MONOLITH CISTERNA MONOLITH БАЧОК MONOLITH



Cassetta esterna in ceramica per installazione con vasi a filo muro. Meccanismo interno Geberit, doppio scarico 3/6 litri. Entrata acqua posteriore o laterale. Possibilità di installazione con scarico a terra variabile da 10 a 23 cm, oppure a parete.

Chasse d'eau extérieure en céramique pour installation avec cuvette au ras du mur. Mécanisme Geberit avec double touche avec possibilité de réglage à 3 ou 6 litres. Arrivée d'eau arrière ou latérale. Possibilité d'installation avec vidange au sol allant de 10 à 23 cm, ou bien murale.

Ceramic cistern to be used with back-to-wall WCs. Geberit 3/6 litre inner mechanism with dual flush. Rear or side water inlet system Wall or floor outlet. The floor outlet can vary from 10 to 23 cm.

Cisterna externa de cerámica para instalación de inodoros contra la pared. Mecanismo interno Geberit, doble descarga 3/6 litros. Entrada de agua posterior o lateral. Posibilidad de instalación con descarga de tierra variable de 10 a 23 cm, o bien, de pared.

Vorwand Kasten in Keramik zur Wandmontage. Innen Mechanismus Geberit, Doppelspülung 3/6 l. Wassereingang rückwärtig oder seitlich. Montagemöglichkeit mit senkrechtem oder waagerechtem Abgang, senkrechter Abgang variierbar von 10 bis 23 cm.

Смывной керамический бачок для наружного монтажа к пристенным унитазам. Внутренний механизм Geberit, двойной слив 3-6 литров. Задний или боковой подвод воды. Возможна установка с регулируемым сливом в пол от 10 до 23 см или в стену.



370x900x130

A.P. Attacco posteriore (YOMK)
Back inlet

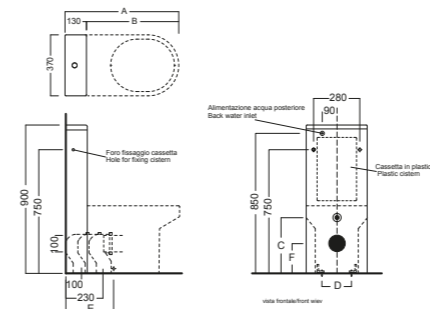

Wc	A	B	C	D	E	F
FUSION	670	540	355	125	300	180
FUSION 48	610	480	360	115	290	190
DAYTIME	690	560	335	145	295	180
DAYTIME EVO	690	560	350	125	290	180
ERIKA PRO Q	660	530	350	125	310	180
NIDO	685	555	340	130	310	180
YOU & ME	635	505	345	200	315	175
YOU & ME corner	635	505	345	-	315	175

370x900x130

A.A. Attacco laterale alto dx/sx (YOYN)
Side-high inlet right/left

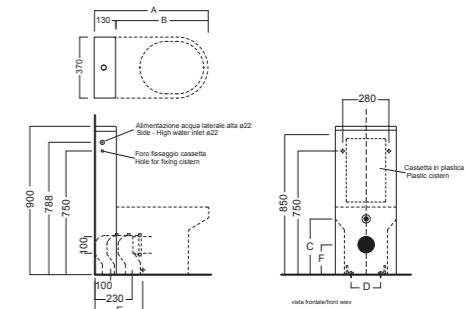

Wc	A	B	C	D	E	F
FUSION	670	540	355	125	300	180
FUSION 48	610	480	360	115	290	190
DAYTIME	690	560	335	145	295	180
DAYTIME EVO	690	560	350	125	290	180
ERIKA PRO Q	660	530	350	125	310	180
NIDO	685	555	340	130	310	180
YOU & ME	635	505	345	200	315	175
YOU & ME corner	635	505	345	-	315	175



FUSION



FUSION



FUSION

ORINATOI / TURCHE / SPECIALI

URINALS / SQUATTING WC / SPECIAL BASINS URINALE / TÜRKISCHE TOILETTE / SPEZIALPRODUKTE URINOIRS / SIÈGE À LA TURQUE / SPÉCIAUX URINARIOS / INODORO A LA TURCA / ESPECIALES ПИССУАРЫ / ЧАША ГЕНУЯ / КОМПЛЕКТУЮЩИЕ

Orinatoi per installazione sospesi a parete. Disponibili anche con coperchio o con sistema di scarico con fotocellula.

Wall-hung urinals. Available also with covers or with photocell flushing system.

Urinale für die hängende Installation an der Wand. Auch mit Deckel oder mit Spülsystem mit Fotozelle erhältlich.

Urinoirs à installer suspendus au mur. Existe aussi avec abattant ou avec système de chasse avec photocellule.

Urinarios para instalación suspendida de pared. Disponibles también con tapa o con sistema de descarga con fotocélula.

Писсуары подвесные для пристенного монтажа. Можно заказать с крышкой или системой слива с фотоэлементом.



YXC3_ORINATOIO FUSION
685x325



YM94_ORINATOIO
500x330



YM93_TURCA
600x520



YXE1_ORINATOIO FUSION
685x325



Y0CA_AUTONOMY
380x595



YXEW_ORINATORIO FUSION ELETT
YXC1_ORINATOIO FUSION BATT
685x325



LIFST

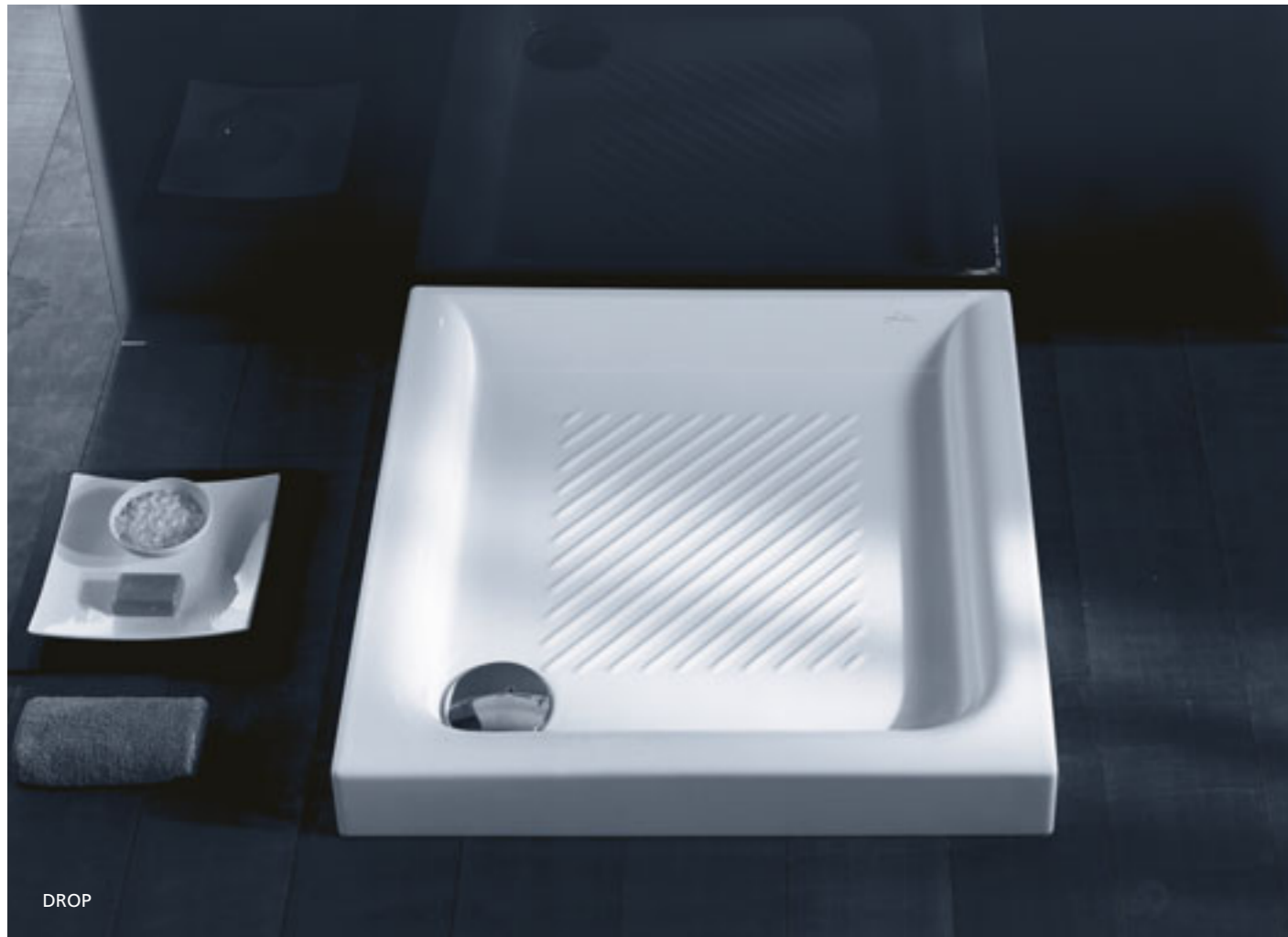

DROP

PIATTI DOCCIA

SHOWER TRAYS DUSCHWANNEN RECEVEURS DE DOUCHE PLATOS DE DUCHA ДУШЕВЫЕ ПОДДОНЫ



Piatti doccia in ceramica o in Heavycril, di diverse forme, misure ed altezze. A seconda dei modelli possono anche essere installati a filo pavimento, con scarico estraibile ed ispezionabile.

Receveurs de douche en céramique ou en Heavycril, de différentes formes, dimensions et hauteurs. Selon les modèles, ils peuvent aussi être installés au ras du sol. Bonde de vidage extractible.

Ceramic or Heavycril ceramic shower trays in different shapes, sizes and heights. According to the models they can also be floor-mounted with removable drain trap for inspection.

Platos de ducha de cerámica o de Heavycril, de distintas formas, medidas y alturas. Según los modelos pueden instalarse también a ras del suelo, con desagüe extraíble e inspeccionable.

Duschwannen aus Keramik oder Heavycril in verschiedenen Formen, Größen und Höhen. Je nach den Modellen können sie auch auf der Höhe des Fußbodens, mit abnehmbarem, einsehbarem Abfluss installiert werden.

Душевые поддоны керамические или акриловые (Heavycril), различных форм, размеров и глубины. В зависимости от модели могут также устанавливаться в пол и быть оснащены съемным ревизионным гидрозатвором.

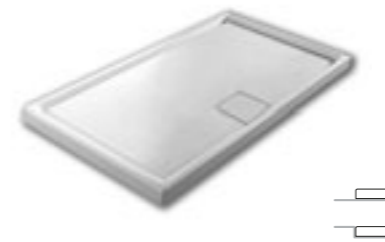

HEAVYCRIL
YXEX_LIF.ST 1600x800x45
YXZ_LIF.ST 1400x800x45
YXF2_LIF.ST 1500x800x45

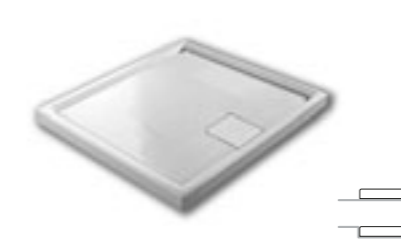

CERAMICA
YXE6_LIF.ST 900x900x60
YXEK_LIF.ST 800x800x60

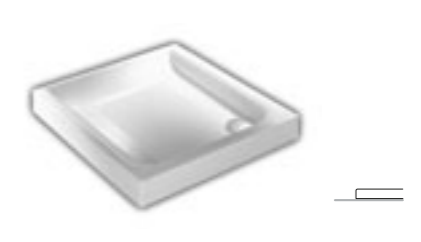

Y0NY_DROP 900x900x110
Y0Y5_DROP 800x800x110

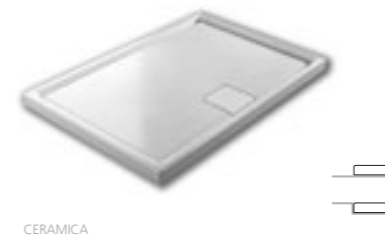

CERAMICA
YXE8_LIF.ST 1200x800x60
YXE7_LIF.ST 1000x800x60



Y0CB_AUTONOMY 800x800
Y0CK_AUTONOMY 900x900



Y0GL_DROP 900x900x110
Y0GL_DROP 800x800x110

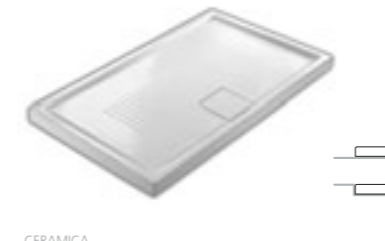

CERAMICA
YXMI_LIF.ST 1200x700x60
YXMJ_LIF.ST 1000x700x60
YXMK_LIF.ST 900x700x60



Y0R5_DROP 1200x800x110
Y0ZZ_DROP 1000x800x110
Y0Y7_DROP 910x730x110
Y0ZW_DROP 1200x700x110
Y0ZX_DROP 1000x700x110



YXBG_DROP 700x900x110 dx
YXBF_DROP 700x900x110 sx



LIFST 160x80_HEAVYCRIL

LIF.ST showertyays

160x80



150x80



140x80

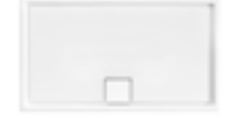

LIFST 100x70_CERAMICA

120x70



120x80

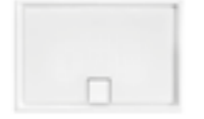

100x70



100x80

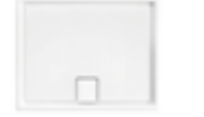

90x70



80x80



90x90

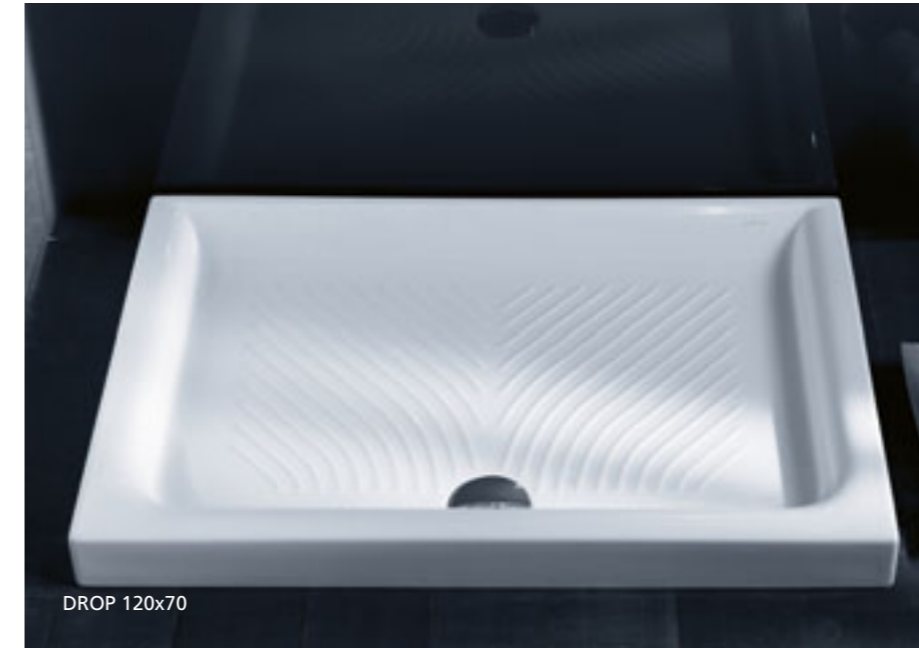

DROP 120x70

DROP

120x80



100x80



120x70



100x70



91x73

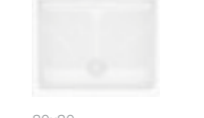

80x80



90x90



80x80



90x90



70x90 dx



70x90 sx

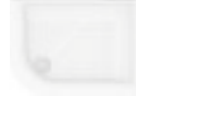

DROP 70x90 dx

ACCESSORI ACCESSORIES_LIFST



piletta da 90 mm quadrata con coperchio bianco
siphon drainage 90 mm with square white cover

ACCESSORI ACCESSORIES_DROP



piletta completa con coperchio cromato 90 mm
complete siphon drainage with chromate cover 90 mm



AUTONOMY

Collezione di sanitari e accessori che coniugano funzionalità e design, facilitando la mobilità nell'ambiente bagno. Lavabo con bordi arrotondati per facilitare la presa, vaso con apertura frontale e un'ampia gamma di accessori in acciaio diam.32 mm zinacato e verniciato bianco.

Collection d'articles sanitaires et d'accessoires alliant fonctionnalité et design, facilitant les allées et venues dans la salle de bains. Lavabo à bords arrondis pour faciliter la prise, cuvette à ouverture frontale et vaste gamme d'accessoires en acier galvanisé et peint en blanc de 32 mm de diamètre.

The bathroom fixtures and accessories collection combines functionality and design, enhancing mobility in the bathroom environment. A washbasin with round edges to facilitate grip, a WC with front opening and a wide range of 32 mm diameter galvanised steel accessories and painted white.

Colectión de sanitarios y accesorios que conjugan funcionalidad y diseño, facilitando la movilidad en el cuarto de baño. Lavabo con bordes redondeados para facilitar el agarre, inodoro con apertura frontal y una amplia gama de accesorios de acero de 32 mm de diámetro galvanizado y pintado blanco.

Kollektion aus sanitären Einrichtungen und Zubehör, die Funktionalität mit Design verbinden und die Bewegung im Badezimmer erleichtern. Waschbecken mit abgerundeten Rändern für einen besseren Halt, Klosett mit vorderer Öffnung und eine breite Palette an Zubehör aus verzinktem und weiß lackiertem Stahl mit 32 mm Durchmesser.

Коллекция санфаянса и комплектующих, сочетающих функциональность и дизайн, делающих более просторным помещение ванной комнаты. Умывальник с удобным закругленным бортом, унитаз с фронтальной прорезью на борту и широкий выбор комплектующих диаметром 32 мм из стали оцинкованной и крашеной белого цвета.



Y0BV_AUTONOMY
680x600

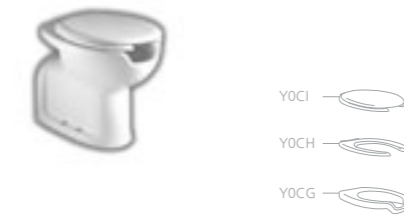

Y0CA_AUTONOMY
380x595



Y0CB_AUTONOMY
800x800

Y0CK_AUTONOMY
900x900



Y0CW_30 cm
Y0CY_45 cm
Y0CX_60 cm
Y0CJ_90 cm
Y0CL_120 cm

Y0CM_150 cm
Y0CN_180 cm
Y0CP_200 cm

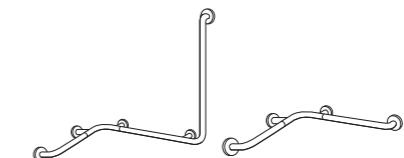

Y0CV_DX - RH
670x670x780

Y0CT
670x670

Y0CZ_SX - LH
670x670x780

Y0CU
770x770

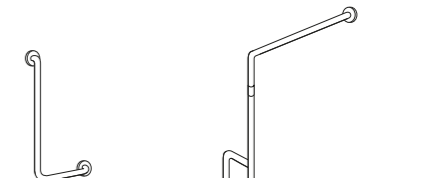

Y0CS_SX - LH
670x350

Y0D9
800x780x135

Y0CR_DX - RH
670x350

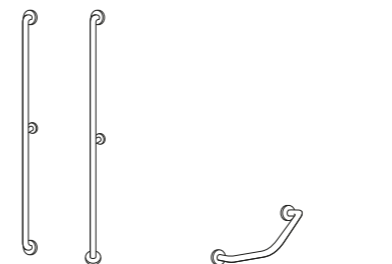

Y0D7_160 cm
Y0D8_180 cm

Y0CQ_50 cm

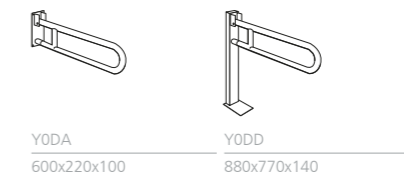

Y0DA
600x220x100

Y0DD
880x770x140

Y0DB
830x220x100

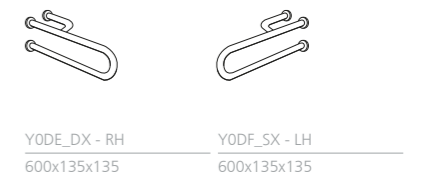

Y0DE_DX - RH
600x135x135

Y0DF_SX - LH
600x135x135

Y0DG_DX - RH
830x135x135

Y0DH_SX - LH
830x135x135



Y0DY
405x300

Y0DK
405x500

Y0DW
505x600

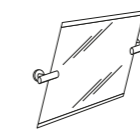

Y0DI
500x600



le pagine
tecniche

G-FULL® 120-140

DESIGN NILO GIOACCHINI



2009

reddot design award
winner 2011



LEGNO MASSELLO TRATTATO IN SUPERFICIE CON IDROREPELENTE
SOLID WOOD SURFACE TREATED WITH WATERPROOF SEALANT



COMPOSITO LIGNEO LACCATO BIANCO
WHITE LACQUERED WOOD COMPOSITE



CHIUSURA PANCA CON CERNIERE FRIZIONATE
CLUTCH CONTROLLED BENCH CLOSURE



VERSIONE VASO DX 120-140



RH TOILET PAN VERSION 120-140



VERSIONE VASO SX 120-140

LH TOILET PAN VERSION 120-140

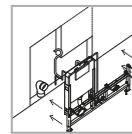

STAFFA SPECIALE REVERSIBILE INCASSO PER PARETI IN MURATURA
SPECIAL REVERSIBLE BUILT IN BRACKET BRICK WALL

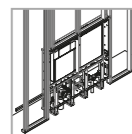

STAFFA SPECIALE DX / SX PER PARETI IN CARTONGESSO
SPECIAL RIGHT / LEFT BRACKET FOR PLASTERBOARD WALL



VASO SCARICO UTILE 4,5 LT
WC, EFFECTIVE FLUSH 4.5 LT



SEDILE ESTRAIBILE
REMOVABLE TOILET SEAT



SEDILE FRENATO
SOFT CLOSE SEAT COVER



DOPPIA EROGAZIONE BIDET
TWIN BIDET WATER DELIVERY NOZZLES



FLUSSO D'ACQUA REGOLABILE
ADJUSTABLE WATER FLOW



EROGATORI SNODATI
ADJUSTABLE NOZZLES



INSTALLAZIONE FACILE CASSETTO
EASY CISTERN INSTALLATION



CASSETTO CONTENITORE 120 DX/SX UNIVERSALE
UNIVERSAL R/L 120 CABINET



COMANDO MISCELATORE
MIXER CONTROL LEVER



PULSANTE DI SCARICO
FLUSH BUTTON

G-FULL® 120 SPECIAL EDITION

DESIGN NILO GIOACCHINI



VERSIONE MONOFORO O SENZA FORO
ONE-HOLE OR HOLE-LESS VERSION



VERSIONE VASO DX/SX
RH/LH TOILET PAN VERSION



LEGNO MASSELLO TRATTATO IN SUPERFICIE CON IDROREPELENTE
SOLID WOOD SURFACE TREATED WITH WATERPROOF SEALANT



COMPOSITO LIGNEO LACCATO BIANCO
WHITE LACQUERED WOOD COMPOSITE



SISTEMA EASYWARM (A RICHIESTA)
EASYWARM SYSTEM (UPON REQUEST)

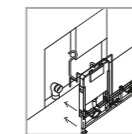
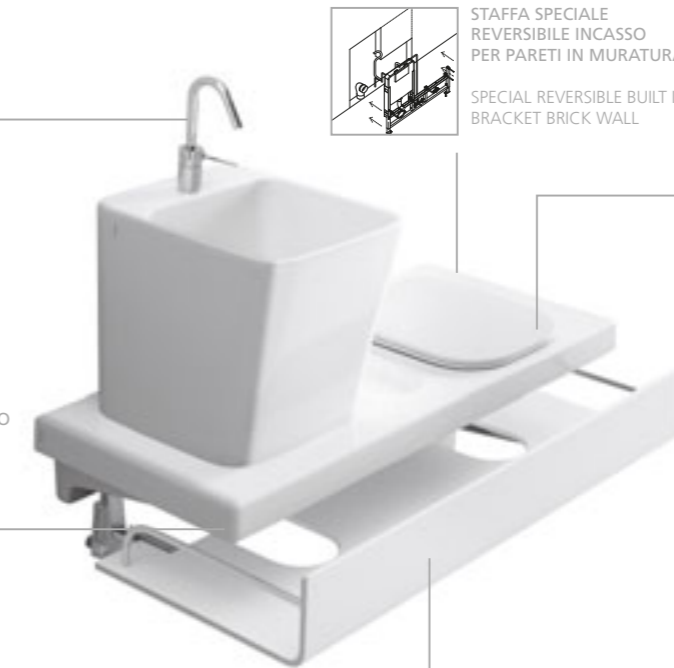

STAFFA SPECIALE REVERSIBILE INCASSO PER PARETI IN MURATURA
SPECIAL REVERSIBLE BUILT IN BRACKET BRICK WALL

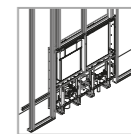

STAFFA SPECIALE DX / SX PER PARETI IN CARTONGESSO
SPECIAL RIGHT / LEFT BRACKET FOR PLASTERBOARD WALL



SEDILE ESTRAIBILE
REMOVABLE TOILET SEAT



SEDILE FRENATO
SOFT CLOSE SEAT COVER



VASO SCARICO UTILE 4,5 LT
WC, EFFECTIVE FLUSH 4.5 LT



INSTALLAZIONE FACILE CASSETTO
EASY CISTERN INSTALLATION



CASSETTO CONTENITORE 120 DX/SX UNIVERSALE
UNIVERSAL R/L 120 CABINET

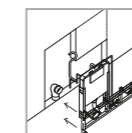

STAFFA SPECIALE REVERSIBILE INCASSO PER PARETI IN MURATURA
SPECIAL REVERSIBLE BUILT IN BRACKET BRICK WALL



STAFFA SPECIALE DX / SX PER PARETI IN CARTONGESSO
SPECIAL RIGHT / LEFT BRACKET FOR PLASTERBOARD WALL



SEDILE E COPERCHIO W.C. ESTRAIBILI
REMOVABLE TOILET SEAT AND LID



SEDILE FRENATO
SOFT CLOSE SEAT COVER



VASO SCARICO UTILE 4,5 LT
WC, EFFECTIVE FLUSH 4.5 LT



PULSANTE DI SCARICO
FLUSH BUTTON

G-FULL®
DESIGN NILO GIOACCHINI



G-FULL 140 1415x500_DX - RH

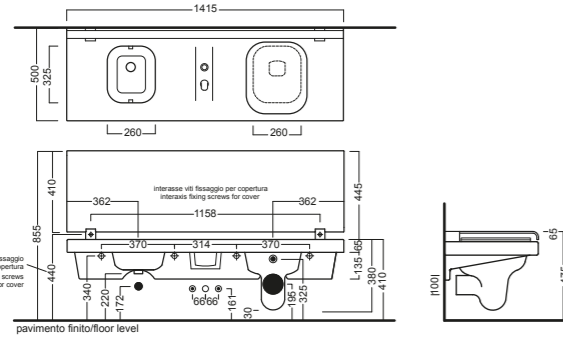

G-FULL 140 1415x500_SX - LH

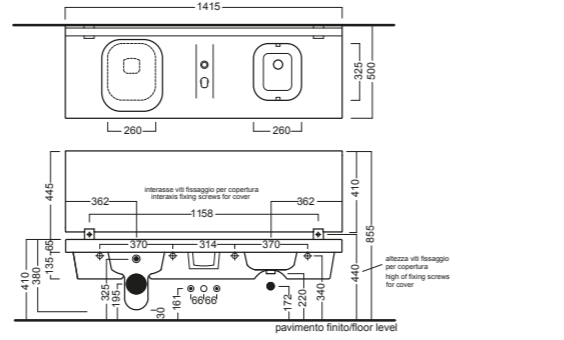

G-FULL 120 CON PILOZZO 1200x500_DX - RH

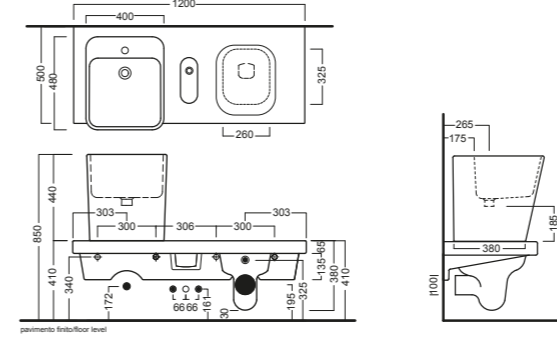

G-FULL 120 CON PILOZZO 1200x500_SX - LH

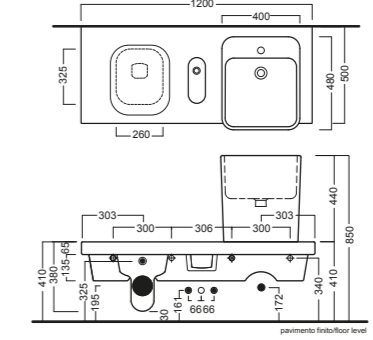

G-FULL 120 1200x500_DX - RH

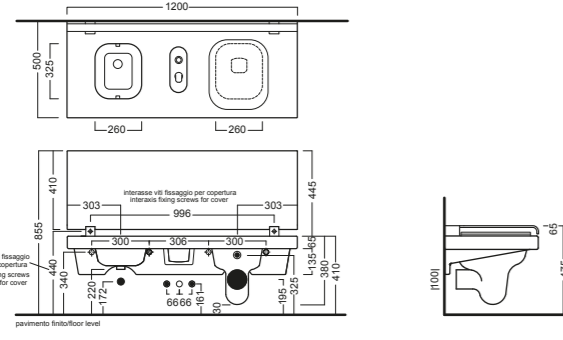

G-FULL 120 1200x500_SX - LH

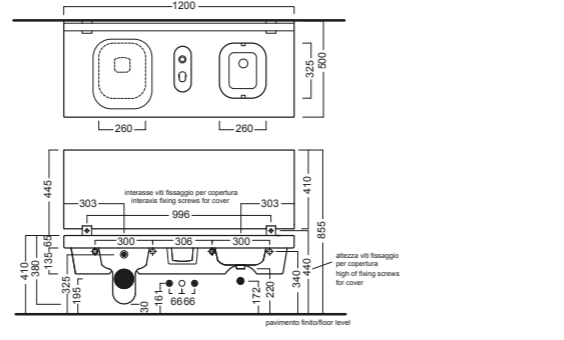

PILOZZO DA APPOGGIO 480x400x440h

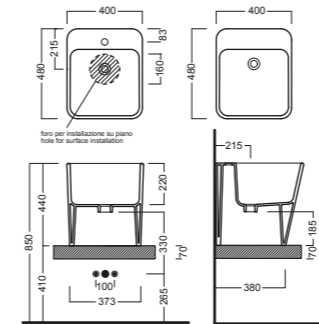

PANCA 1400x500 1200x500 1000x500

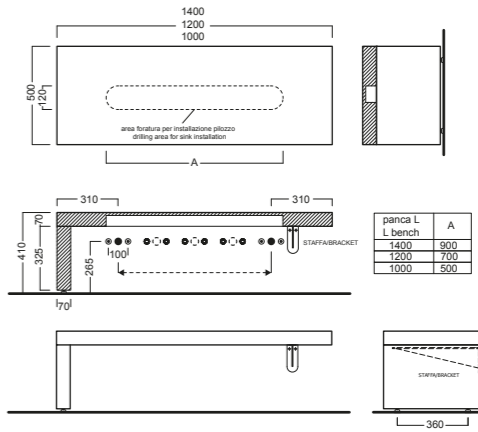

G-FULL 120 1200x500

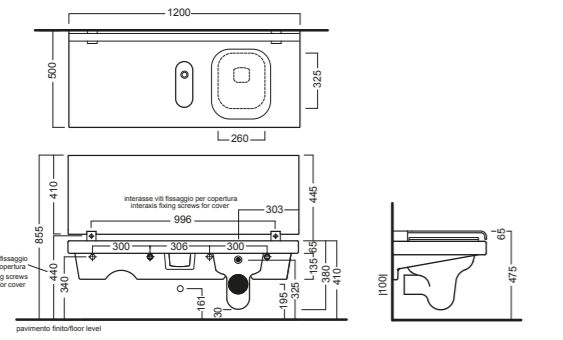

G-FULL 120 1200x500_EASYWARM®

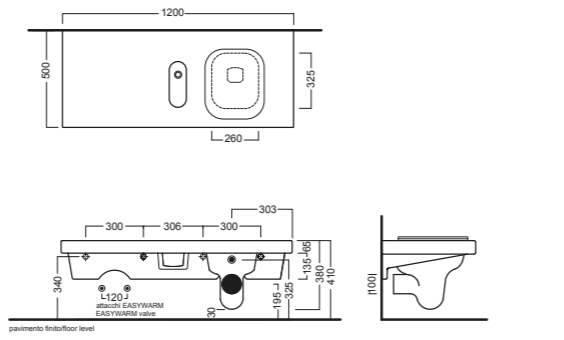

PILOZZO SOSPESO 480x400x440h

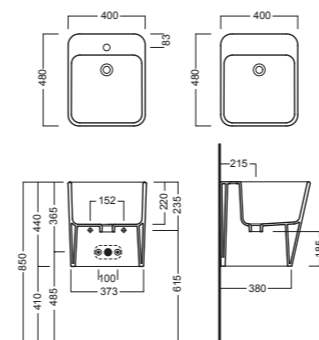



G-130
1300x500 / 1300x500_EASYWARM®

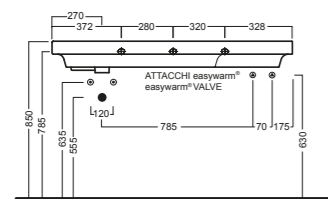
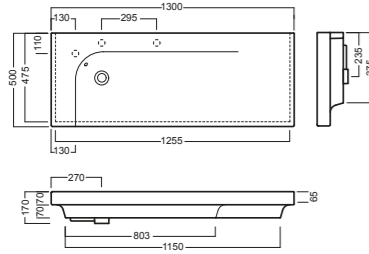

G-130 TRAPEZOIDALE
1300x500x335_DX-RH / 1300x500x335_DX-RH EASYWARM®

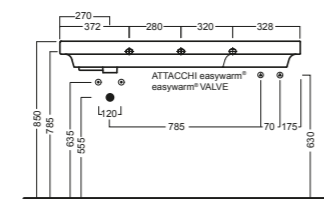
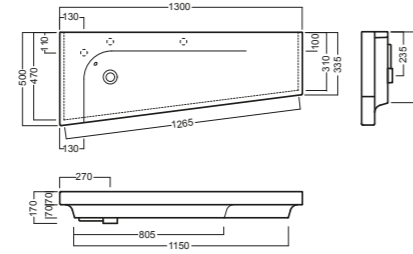

G-130 TRAPEZOIDALE
1300x500x335_SX-LH / 1300x500x335_SX-LH EASYWARM®

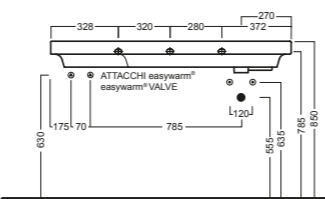
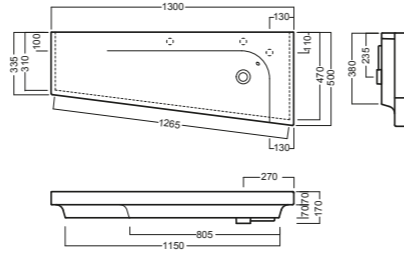

G-150
1500x500

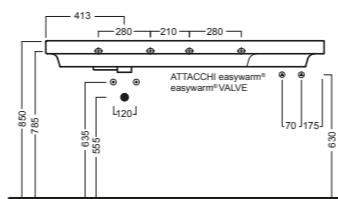
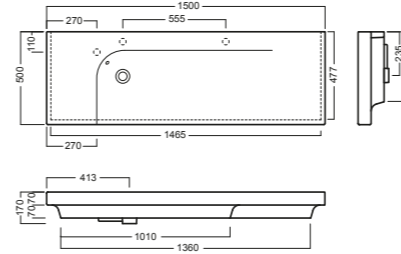

G-75
750x500_DX-RH

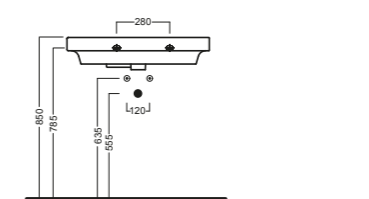
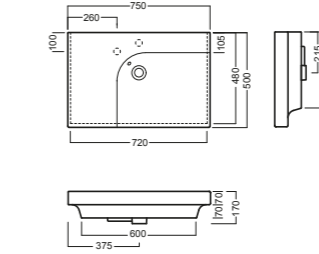

G-75
750x500_SX-LH

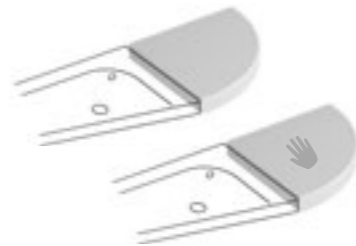
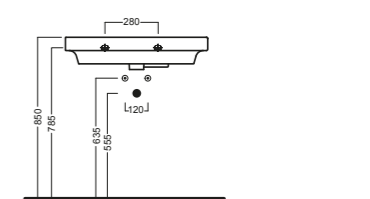
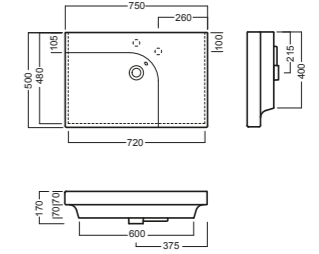

G-50 RIPIANO
500x500_DX-RH / 500x500_DX-RH EASYWARM®

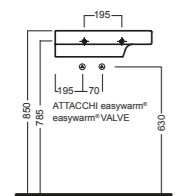
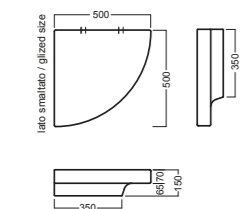

G-50 RIPIANO
500x500_SX-LH / 500x500_SX-LH EASYWARM®

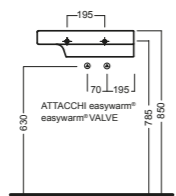
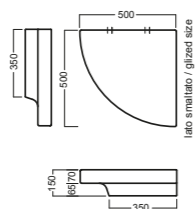

G-100
1000x500

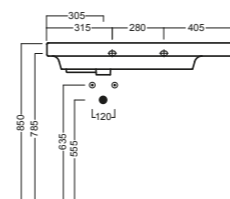
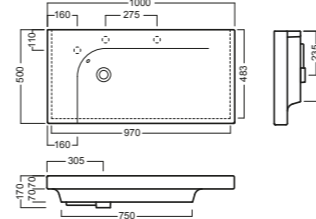

G-50
500x500_DX-RH

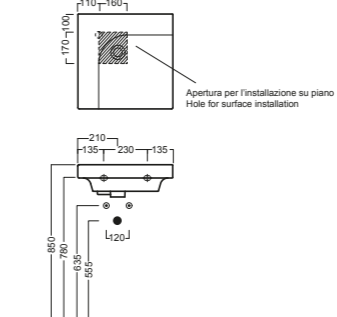
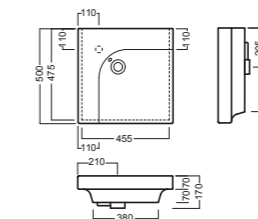

G-50
500x500_SX-LH

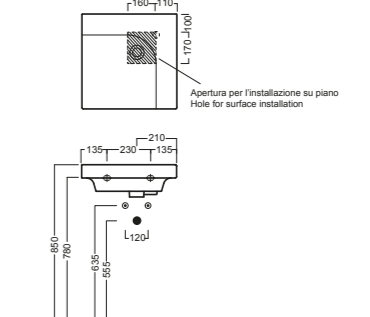
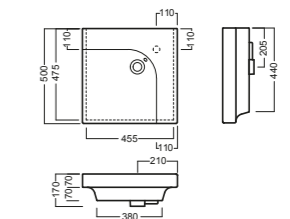

FUSION

DESIGN NILO GIOACCHINI



FUSION 355x540

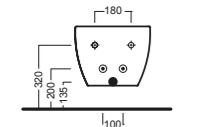
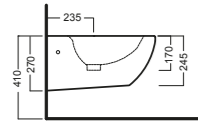
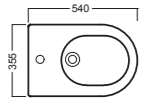

FUSION 355x540

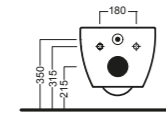
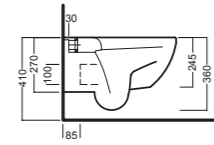
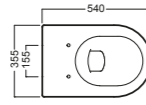

FUSION Q 350x530

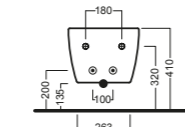
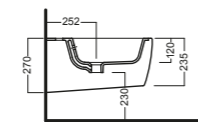
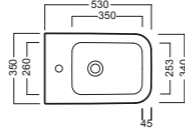

FUSION Q 355x530

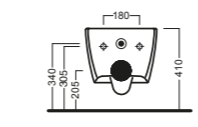
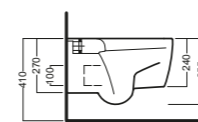
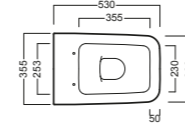

FUSION 355x540

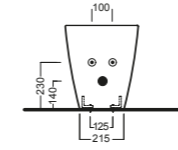
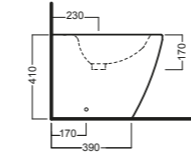
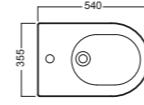

FUSION 355x540

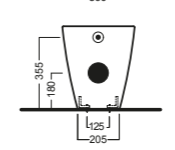
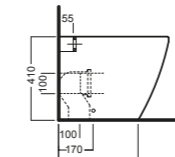
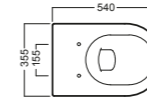

FUSION + MONOLITH 370x670

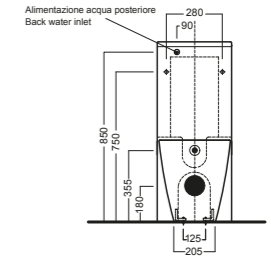
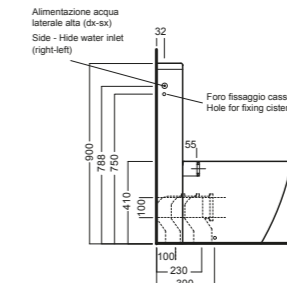
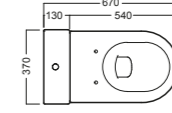

FUSION 48 350x480

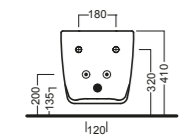
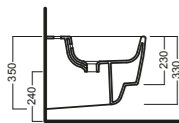
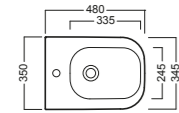

FUSION 48 350x480

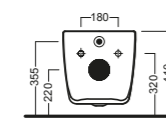
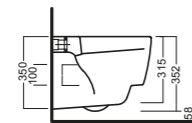
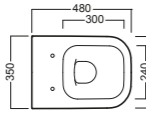

FUSION 48 350x480

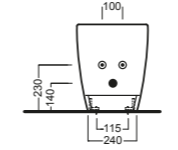
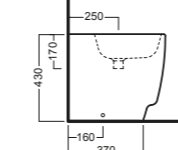
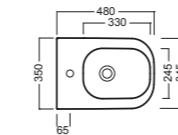

FUSION 48 350x480

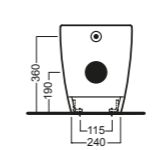
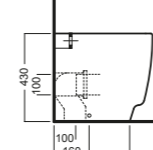
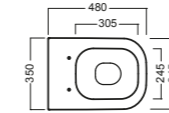

FUSION 48 + MONOLITH 370x610

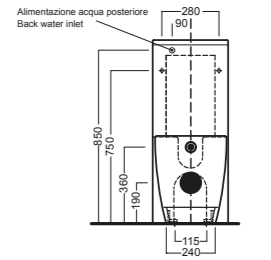
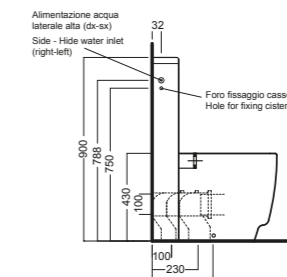
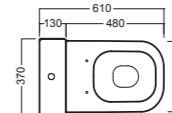

FUSION

DESIGN NILO GIOACCHINI

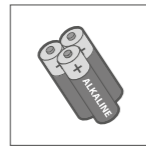

FUNZIONAMENTO A PILE ALKALINE
(3X1,5V) - COD. YXC1
FUNZIONAMENTO ELETTRICO A
RICHIESTA - COD. YXEW
WORKING ON ALKALINE BATTERIES
(3X1,5V) - COD YXC1
ELECTRIC WORKING
ON REQUEST - COD. YXEW

FACILE ISPEZIONE
INTERNA
EASY INTERNAL
INSPECTION



SIFONE SNODABILE
INCORPORATO
BUILT-IN ARTICULATED
SIPHON



SENSORE AD ALLONTANAMENTO
CON REGOLAZIONE RAGGIO
D'AZIONE
SENSOR WITH SETTING OF
SENSORS BEAM



LAVAGGIO OTTIMALE
OPTIMAL WASHING

ALL-IN-ONE
TUTTI GLI ACCESSORI NECESSARI
ALL'INSTALLAZIONE SONO
INCLUSI NELLA CONFEZIONE
ALL THE ACCESSORIES REQUIRED
FOR INSTALLATION ARE INCLUDED
IN THE PACKAGING

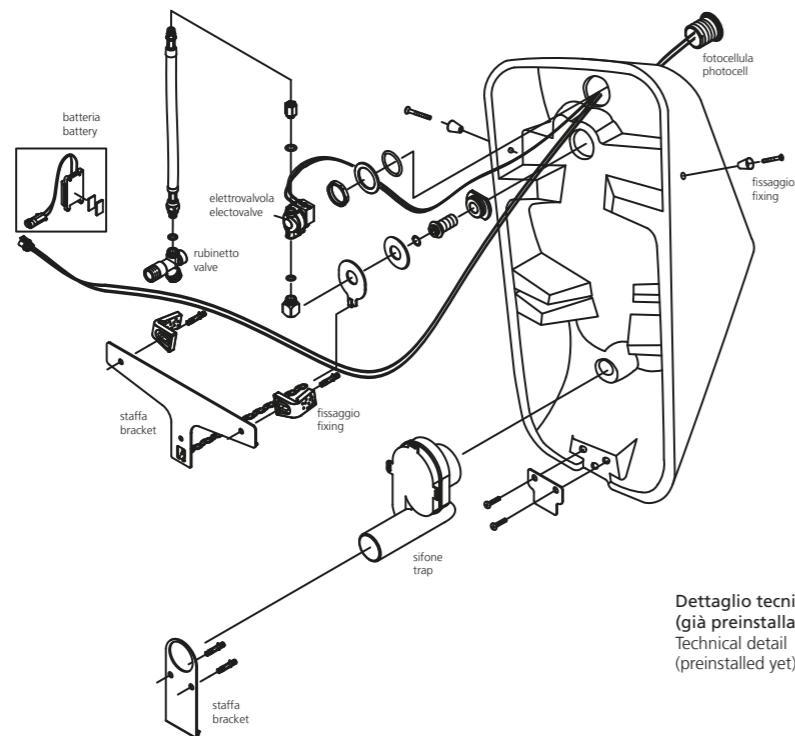

Dettaglio tecnico
(già preinstallato)
Technical detail
(preinstalled yet)



325x685

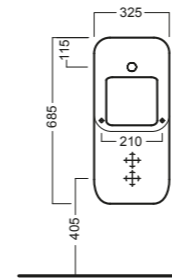

325x685

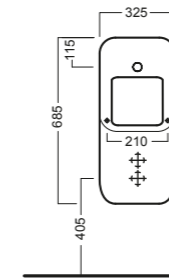

325x685

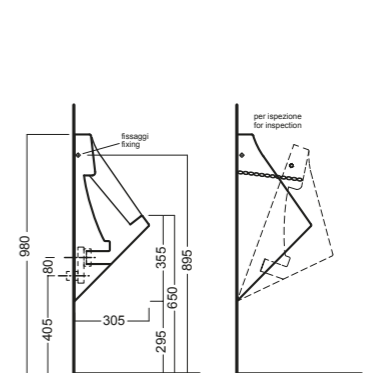
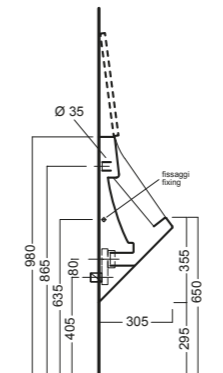
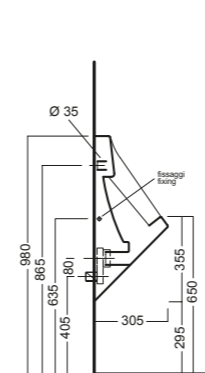
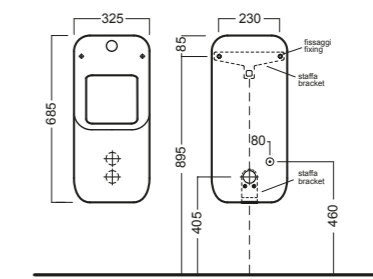



1060x450

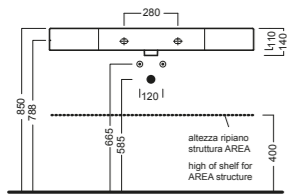
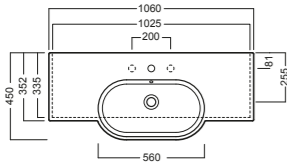

900x450

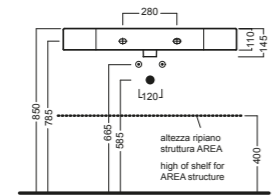
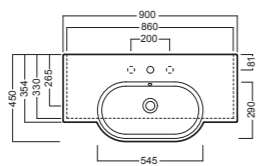

810x450

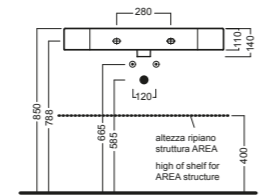
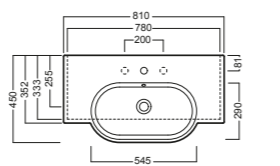

600x450

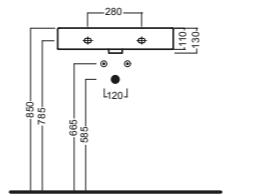
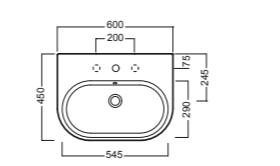

1100x350

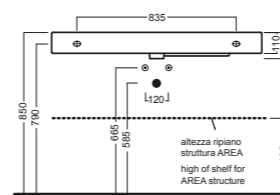
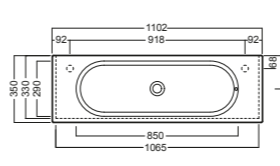

900x350

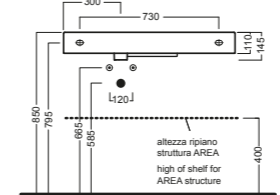
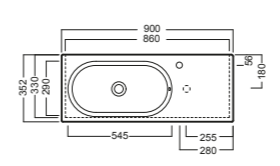

700x350

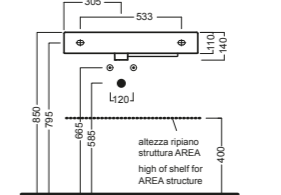
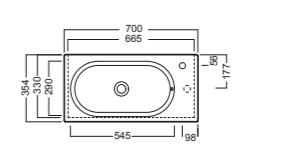

350x350 / 350x350_EASYWARM®

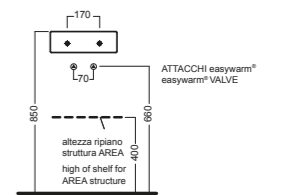
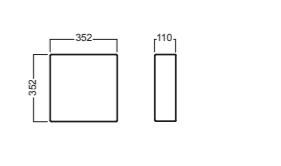

ATTACCHI easywarm®
easywarm® VALVE



900x450_SX-LH

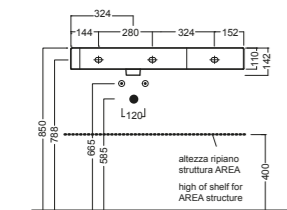
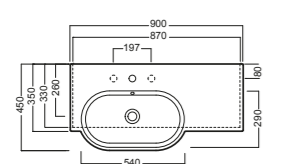

900x450_DX-RH

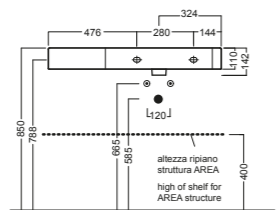
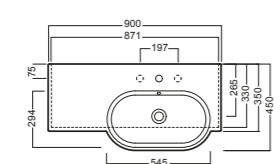

900x500_SX-LH

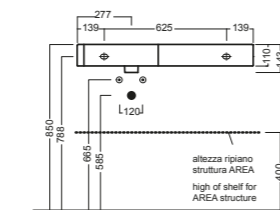
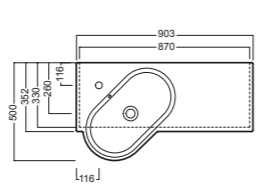

900x500_DX-RH

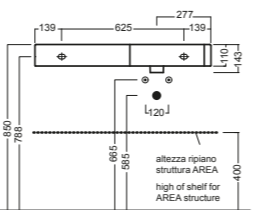
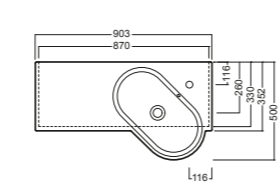

1000x350

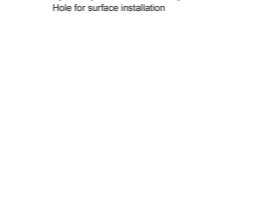
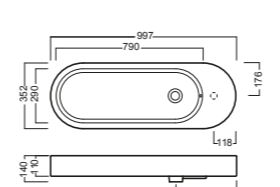

Apertura per l'installazione su piano
Hole for surface installation



800x350

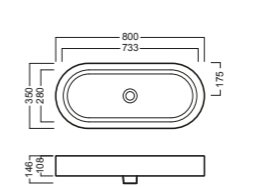

Apertura per l'installazione su piano
Hole for surface installation



470x470_SX-LH

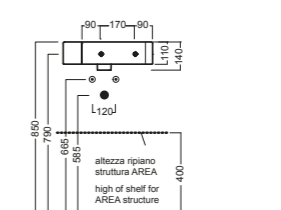
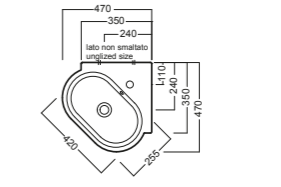

470x470_DX-RH

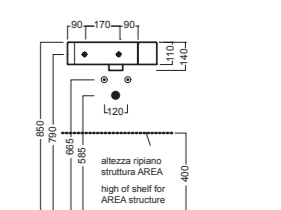
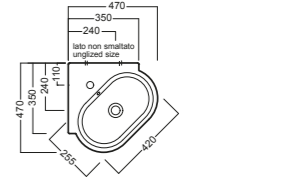

A-WOOD

DESIGN NILO GIOACCHINI

misure tecniche technical measures

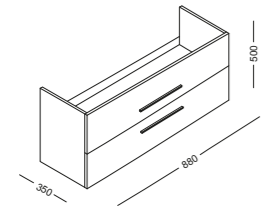

880x500x350

finiture finishes



Bianco Lucido Gloss White



Larice Moro Dark Larchwood



Betulla Naturale Light Birchwood

predisposizioni idrauliche per lavabi AREA 90 hydraulic predrilled for AREA washbasin 90



AREA 90x45 sx - lh

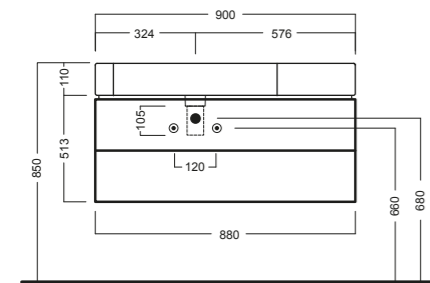

AREA 90x45 dx - rh

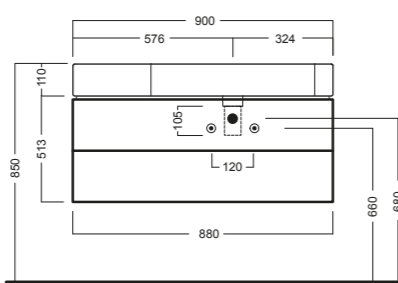

AREA 90x45

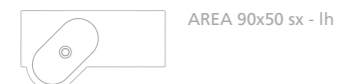
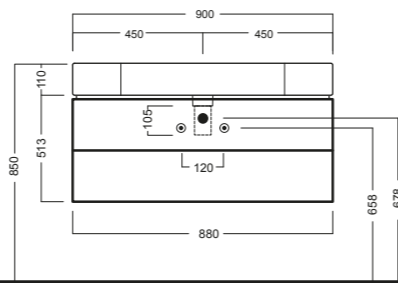

AREA 90x50 sx - lh

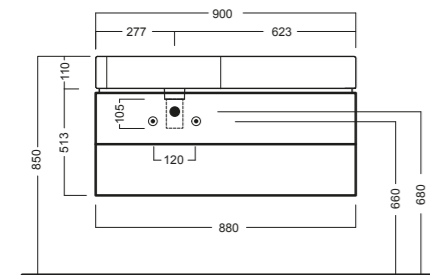

AREA 90x50 dx - rh

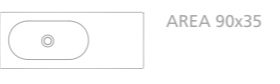
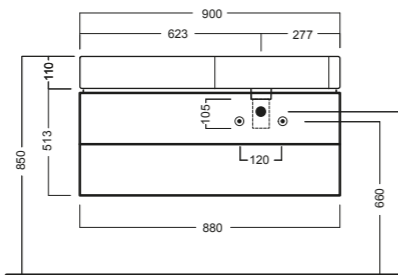

AREA 90x35

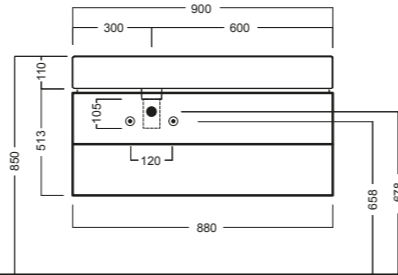

AREA®

DESIGN NILO GIOACCHINI



AREA MEZZALUNA 900x350

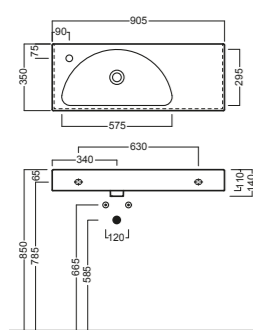

AREA MEZZALUNA 700x350

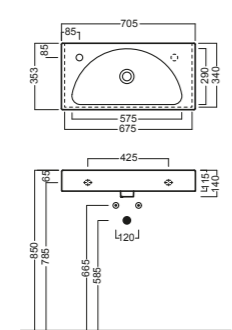

EMILY 1060x500

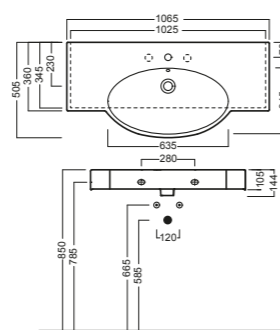

EMILY 810x500

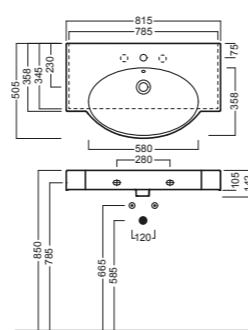

AREA®

DESIGN NILO GIOACCHINI

lavabi washbasins

accessori accessories

	35	35	70	90			
Y0WV 350x350	●	●					●
Y0WF - Y0WH 470x470 dx-rh / sx-lh	●						●
Y0UH 600x450						●	●
Y0UF 800x350					●		●
Y0W1 1000x350					●		●
YXDK 700x350	●	●	●				●
YXDL 900x350	●	●	●	●			●
Y0UP 810x450	●	●	●				●
YXA0 900x450 YXZG 1060x450	●	●	●	●			●
Y0UY 900x450 dx-rh	●	●	●	●			●
Y0U9 900x450 sx-lh	●	●	●	●			●
Y0UD 900x500 dx-rh	●	●	●	●			●
YV80 900x500 sx-lh	●	●	●	●			●
Y0W5 1100x350	●	●	●	●	●		●

HAPPY HOUR



HAPPY HOUR 07:00 440x440

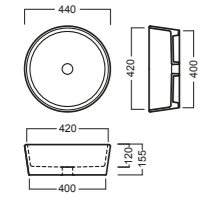

Apertura per l'installazione su piano
Hole for surface installation

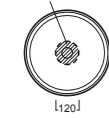

HAPPY HOUR 07:15 440x440

sottopiano

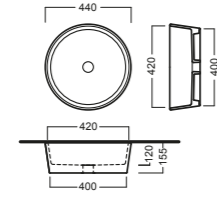

HAPPY HOUR 09:00 480x480

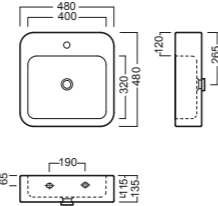

Apertura per l'installazione su piano
Hole for surface installation

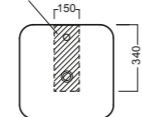

HAPPY HOUR 10:00 398x398

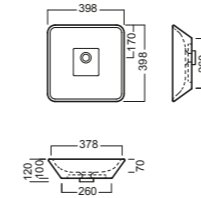

Apertura per l'installazione su piano
Hole for surface installation

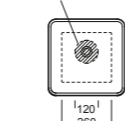

HAPPY HOUR 17:00 550x405

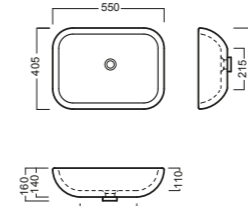

Apertura per l'installazione su piano
Hole for surface installation

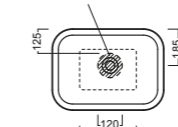

HAPPY HOUR 22:00 700x400

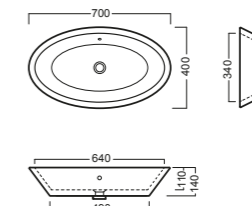

Apertura per l'installazione su piano
Hole for surface installation

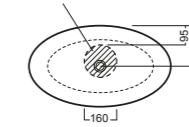

HAPPY HOUR 11:00 500x380

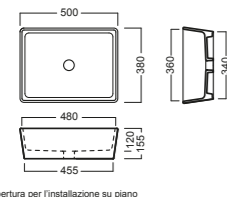

Apertura per l'installazione su piano
Hole for surface installation

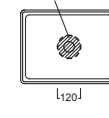

HAPPY HOUR 11:15 500x380

sottopiano

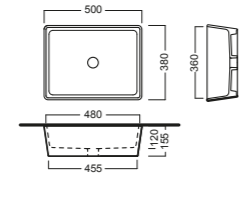

HAPPY HOUR 09:30 480x480

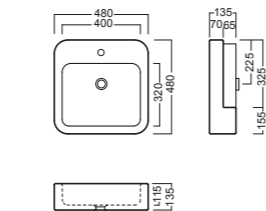

Apertura per l'installazione su piano
Hole for surface installation

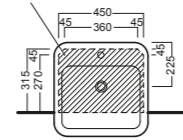

HAPPY HOUR 02:00 475x475

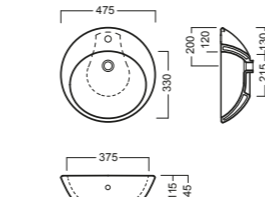

Apertura per l'installazione su piano
Hole for surface installation

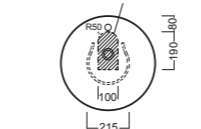

HAPPY HOUR 03:00 470x470

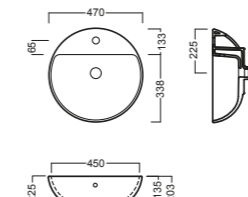

Apertura per l'installazione su piano
Hole for surface installation

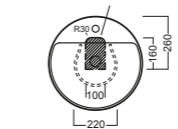

DAYTIME / DAYTIME EVO



1105x500 1105x500 1105x500

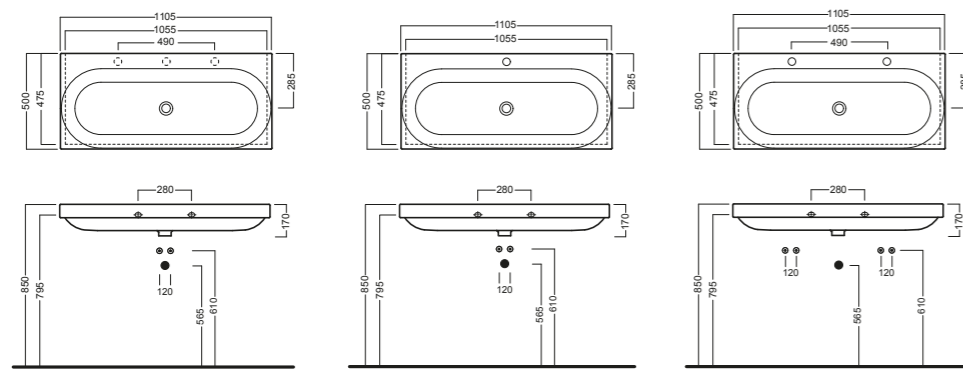

615x430

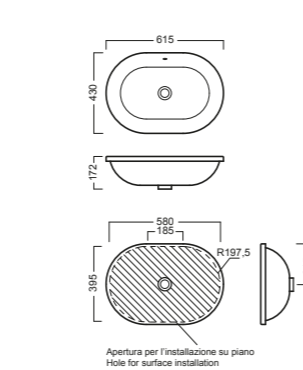

DAYTIME 370x560 DAYTIME 370x560

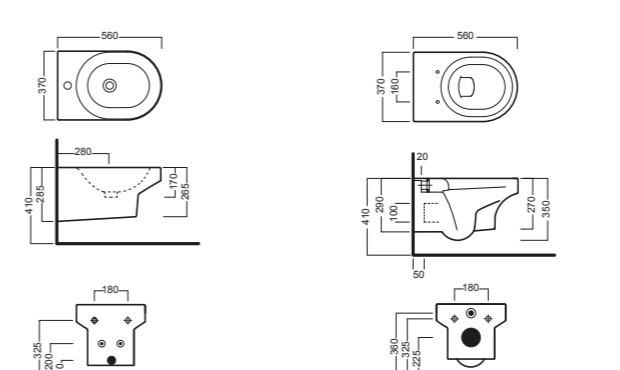

860x500_dx-rh 860x500_sx-lh 700x500 620x500

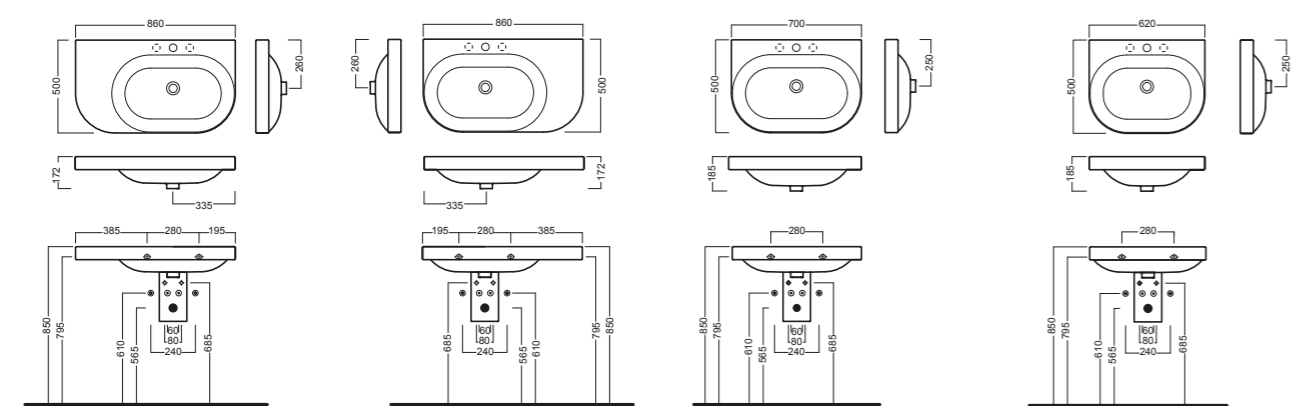

DAYTIME 370x560 DAYTIME 370x560

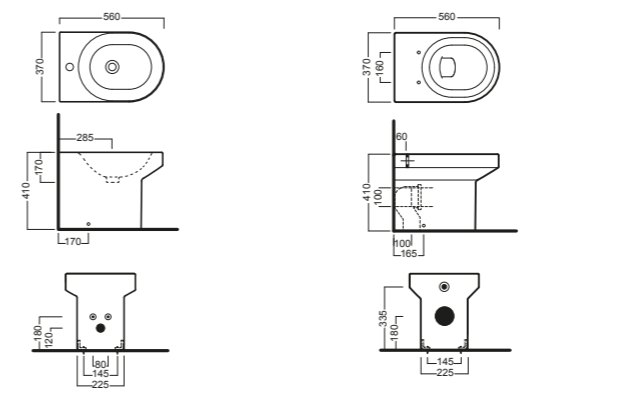

DAYTIME + MONOLITH 370x690

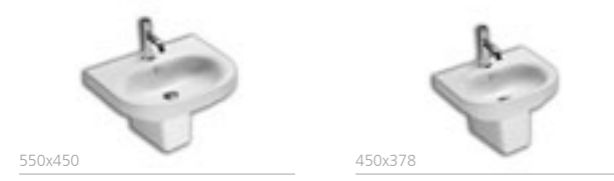
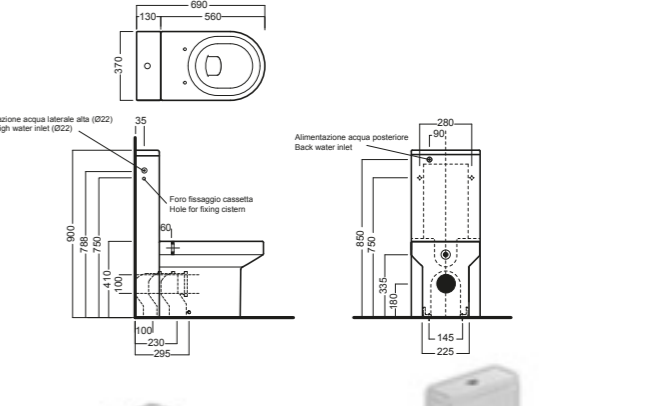

550x450 450x378

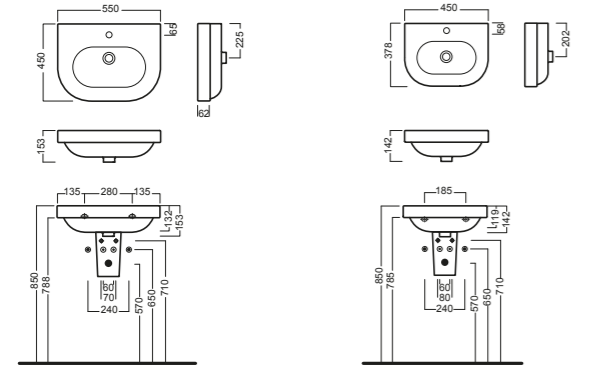

DAYTIME EVO 375x560 DAYTIME EVO 365x560

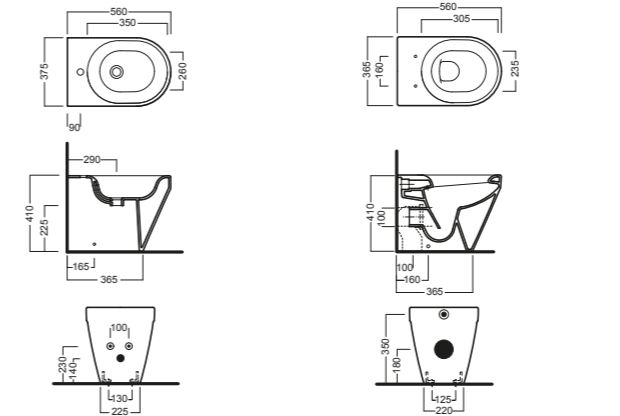

DAYTIME EVO 370x660 DAYTIME EVO + MONOLITH 370x690

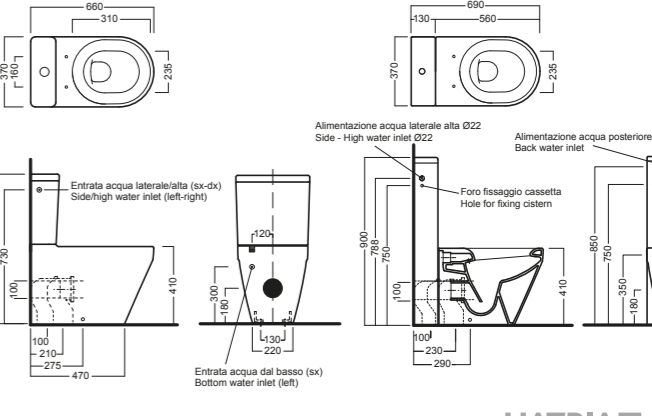

NIDO



680x480

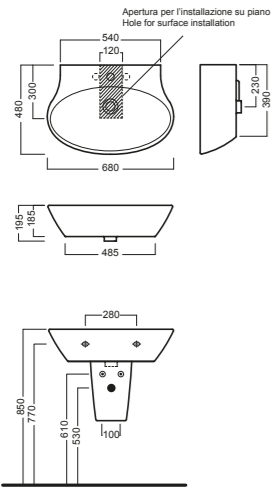

620x470

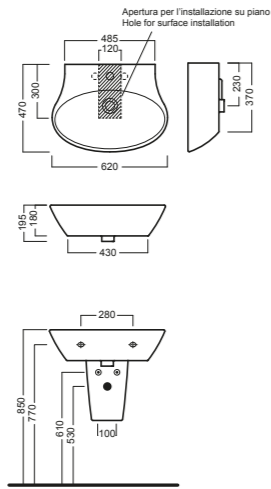

560x445

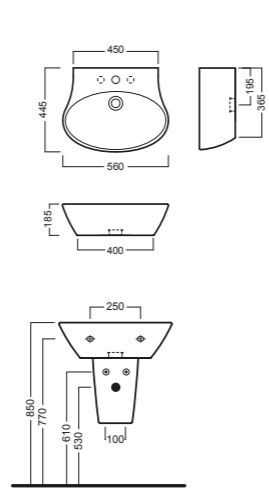

750x370

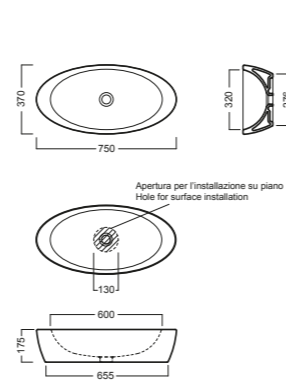

355x555

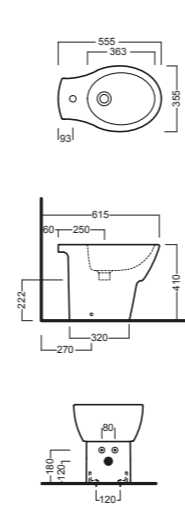

355x555

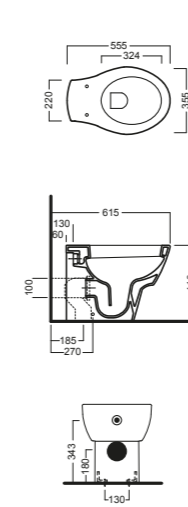

360x555

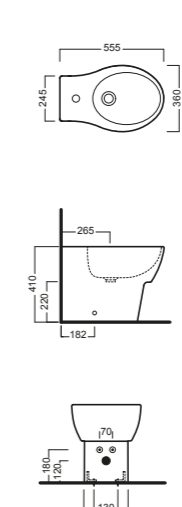

360x555

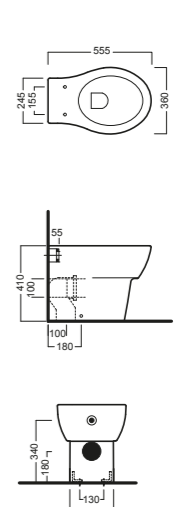

680x480

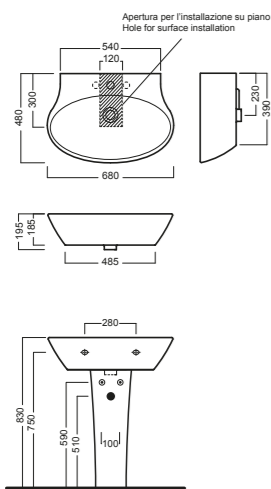

620x470

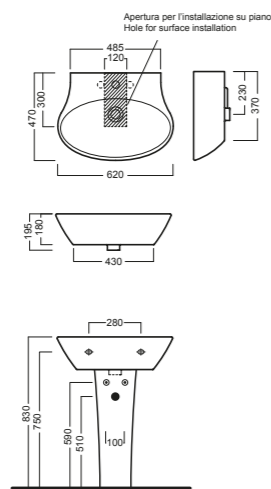

560x445

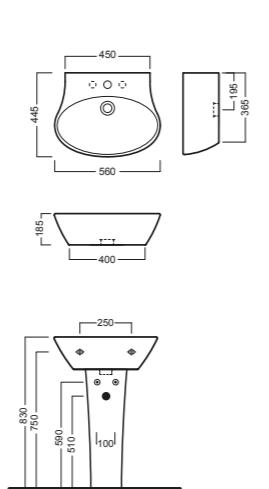

368x550

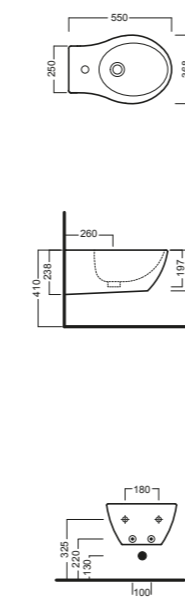

363x548

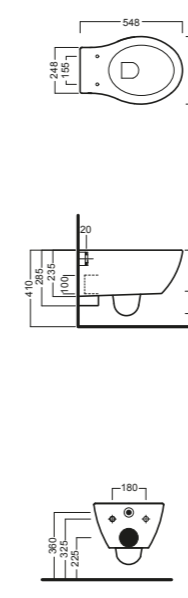

355x655

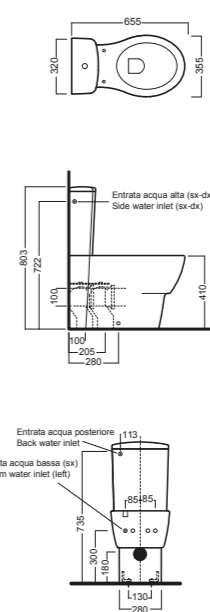

NIDO + MONOLITH 370x685

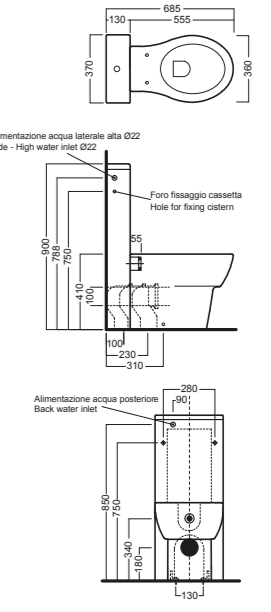

ERIKA PRO / ERIKA PRO Q



1200x450

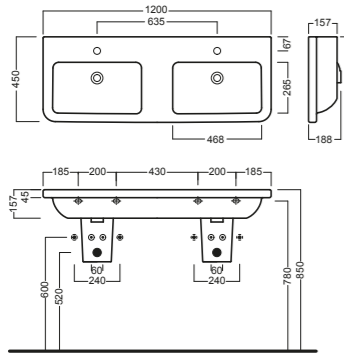

1000x450

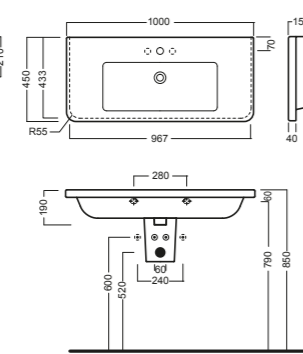

800x450

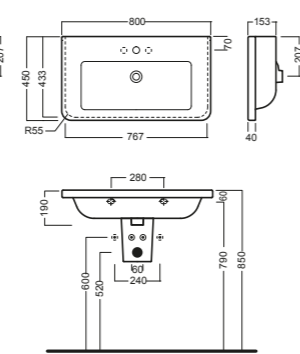

650x450

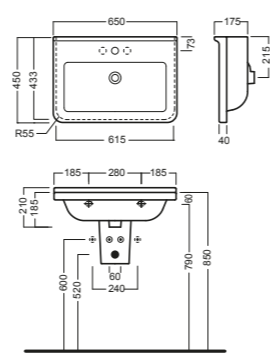

ERIKA pro Q 345x530

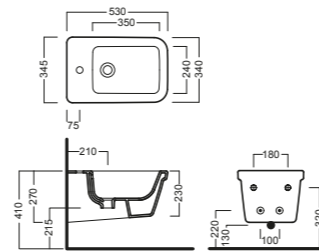

ERIKA pro Q 345x530

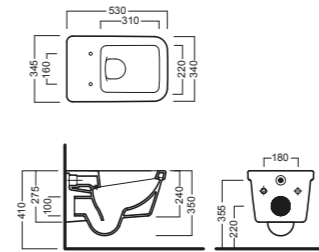

ERIKA pro Q 345x530

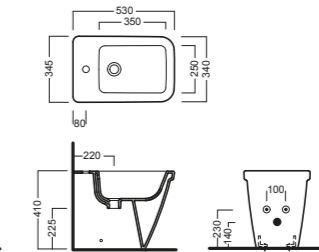

ERIKA pro Q 345x530

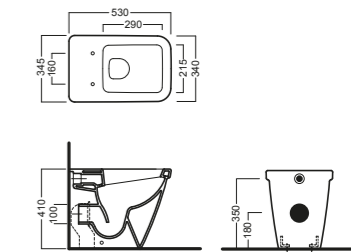

600x450

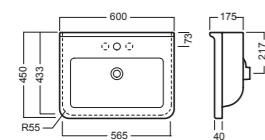

550x450

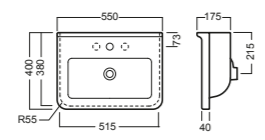

450x380

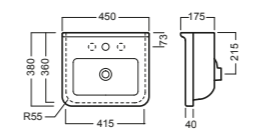

680x480 620x460

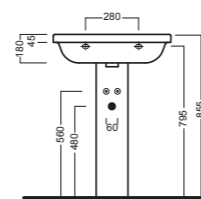
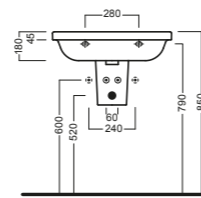
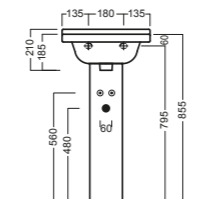
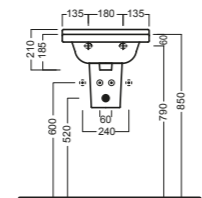
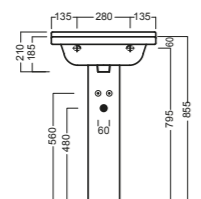
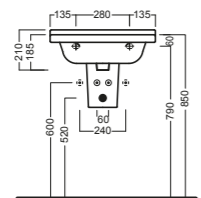
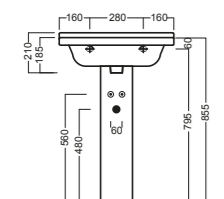
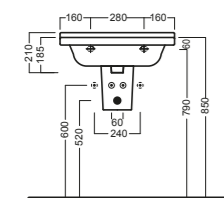
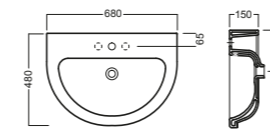

ERIKA pro 370x530

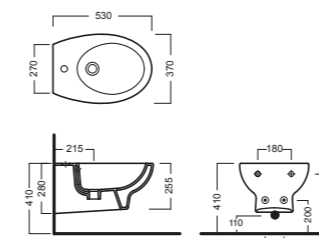

ERIKA pro 370x530

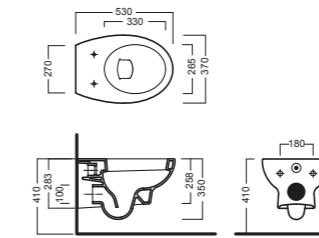

ERIKA pro 370x535

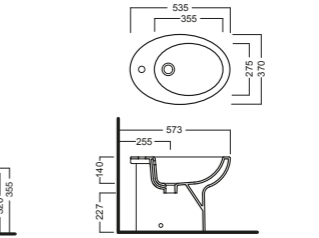

ERIKA pro 370x530

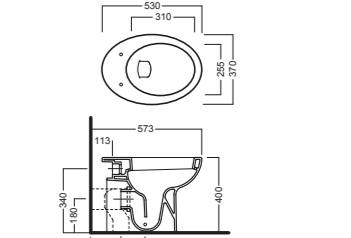

ERIKA pro Q 370x625

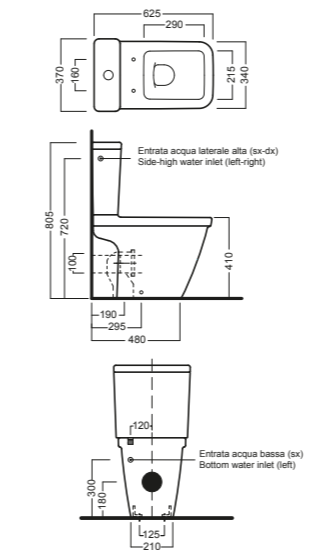

ERIKA pro Q + MONOLITH 370x660

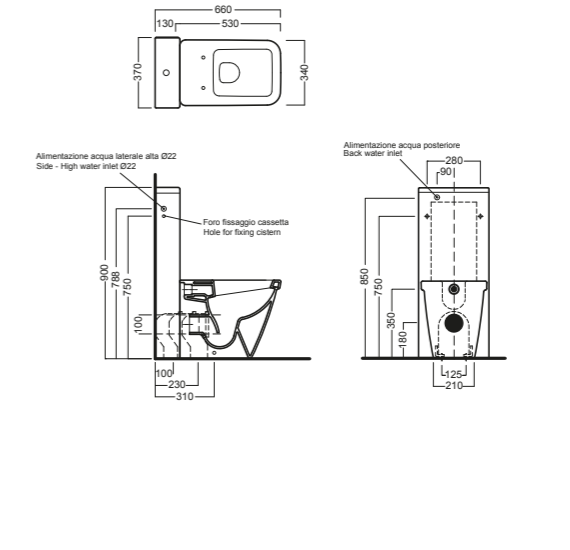

ERIKA pro 370x675

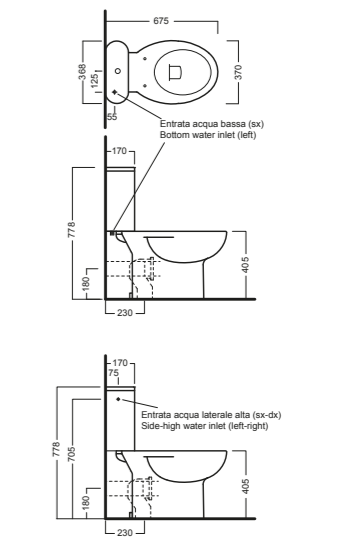

HEAVYCRIL

CERAMIC

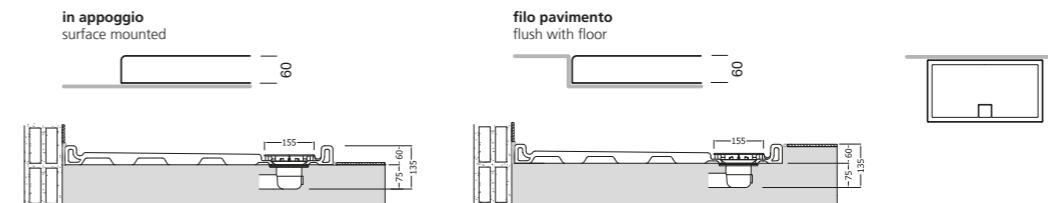
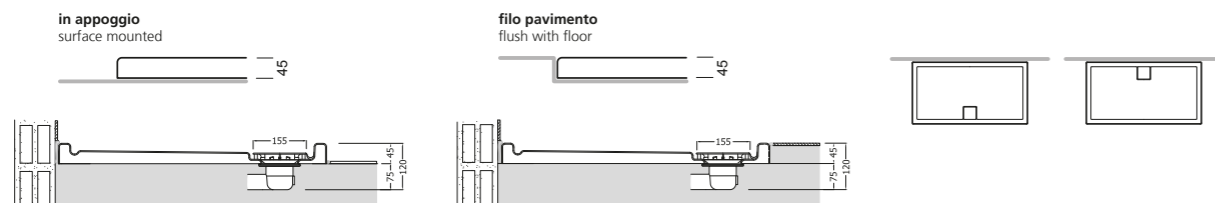
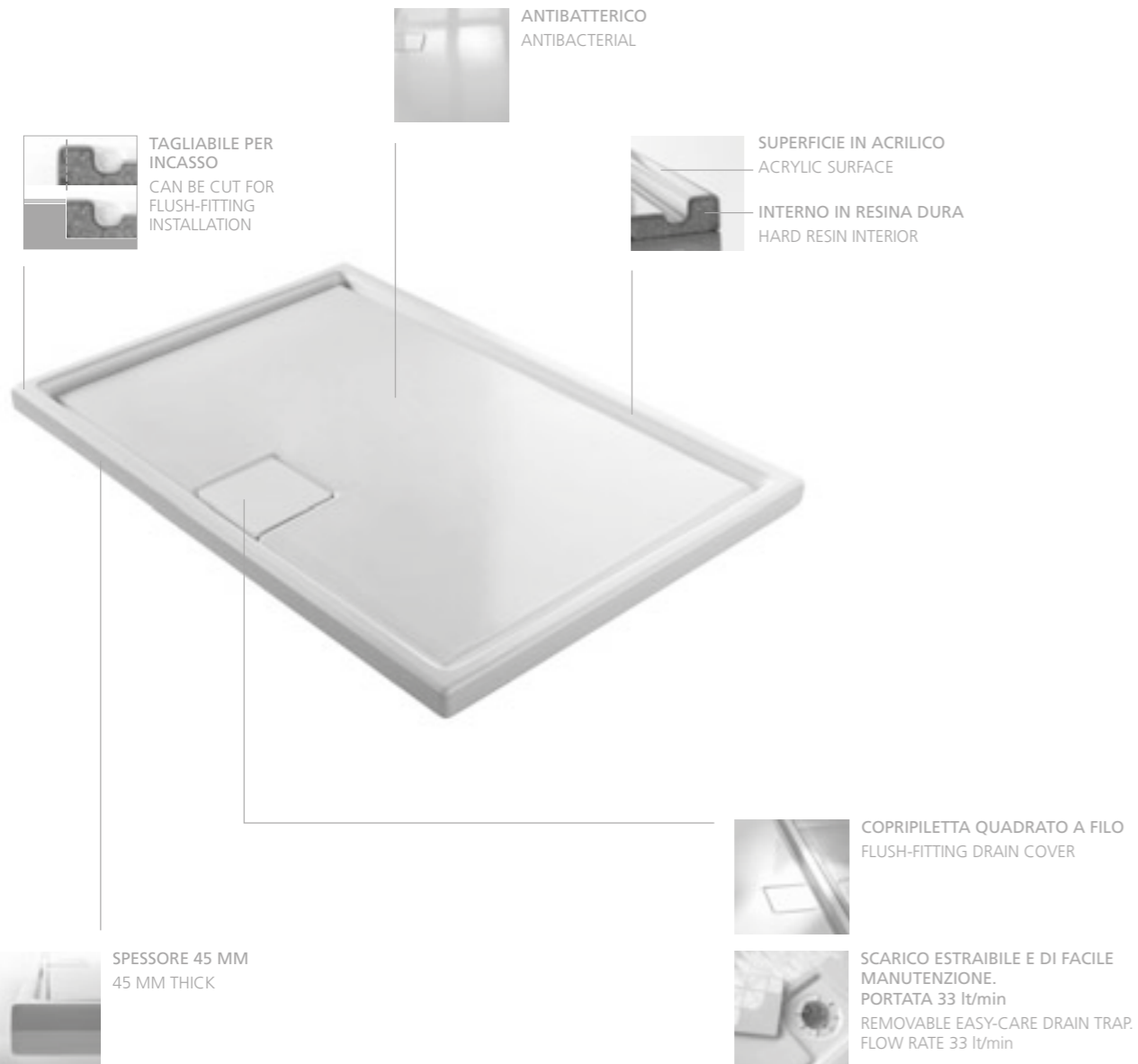

LIF.ST showertrays

DESIGN NILO GIOACCHINI



1600x800x45h

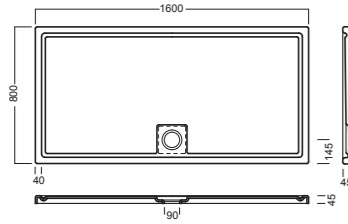

1500x800x45h

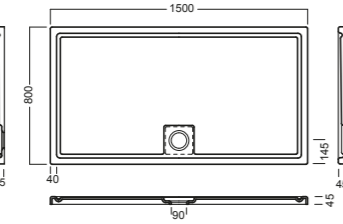

1400x800x45h

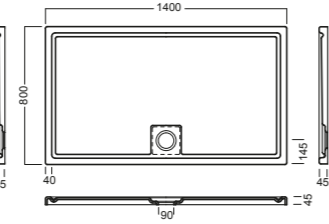

1200x700x60h

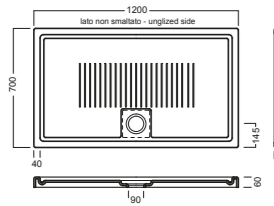

1000x700x60h

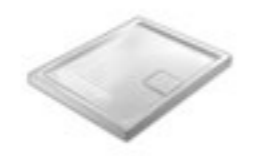
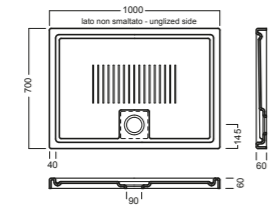

900x700x60h

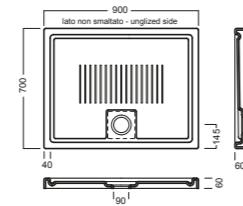

1200x800x60h

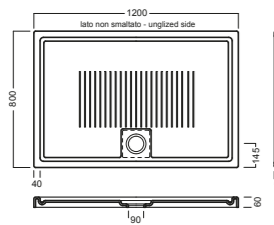

1000x800x60h

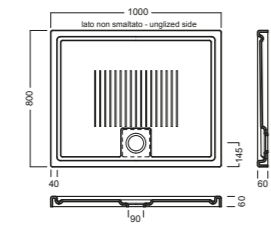

800x800x60h

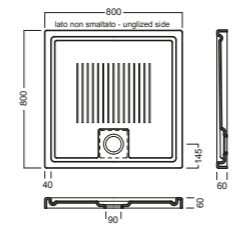

900x900x60h

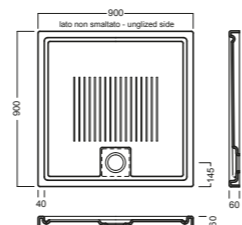

DROP



1200x800x110h

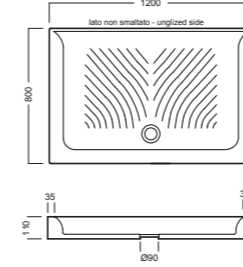

1200x700x110h

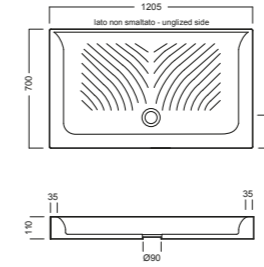

1000x800x110h

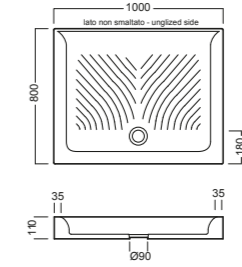

1000x700x110h

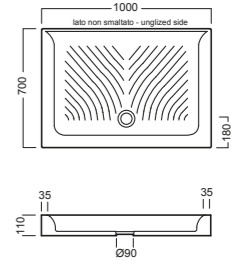

730x910x110h

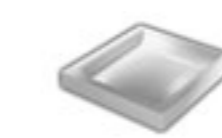
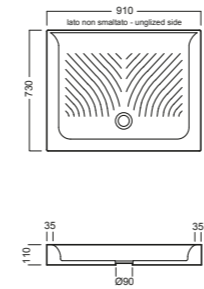

800x800x110h

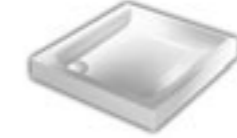
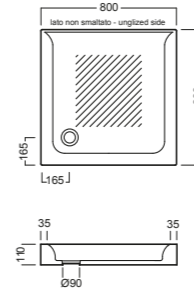

900x900x110h

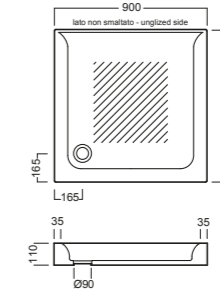

800x800x110h

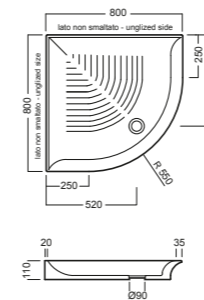

900x900x110h

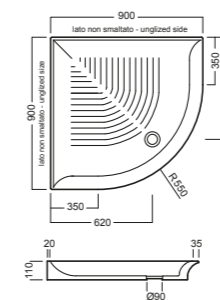

700x900x110h_DX-RH

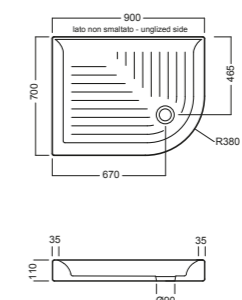

700x900x110h_SX-LH

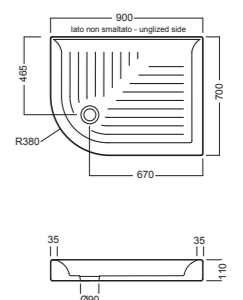

YOU & ME



920x460

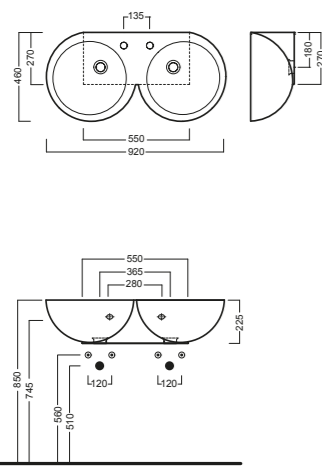

460x460

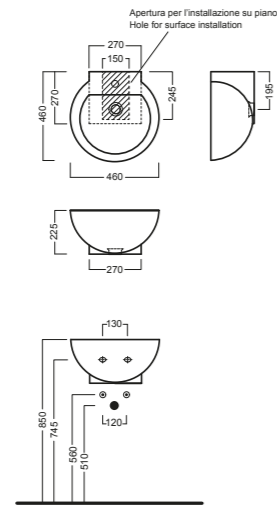

460x460_DX-RH

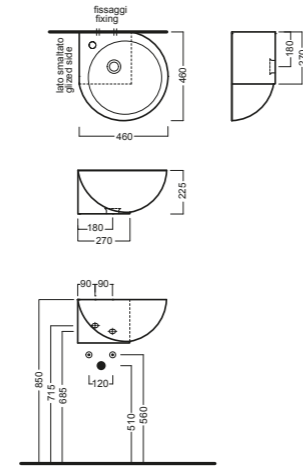

460x460_SX-LH

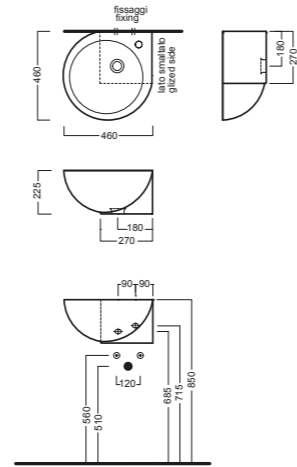

375x505

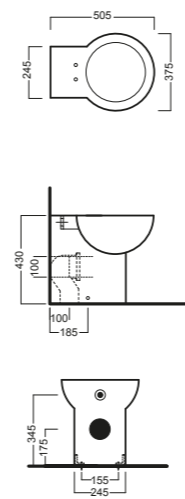

375x505

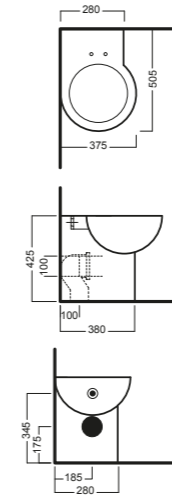

375x505

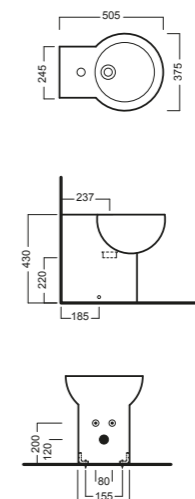

900x460

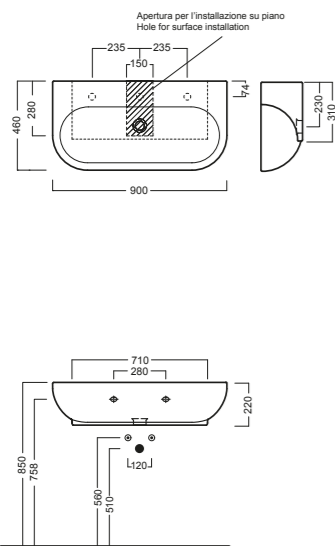

703x445

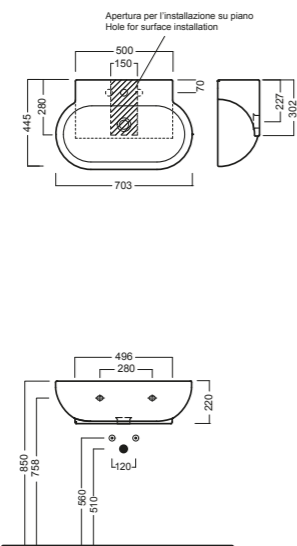

795x370

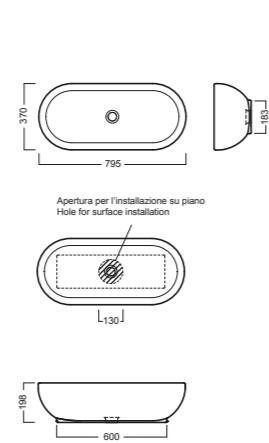

YOU & ME + MONOLITH 375x365

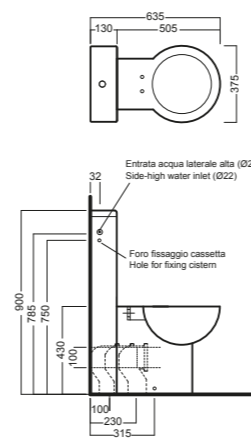

YOU & ME + MONOLITH 375x635

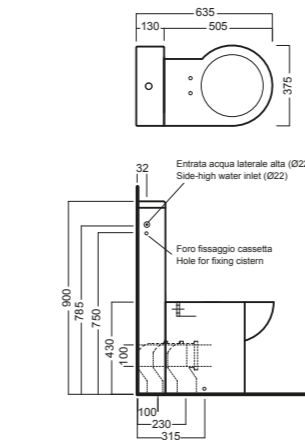

375x505

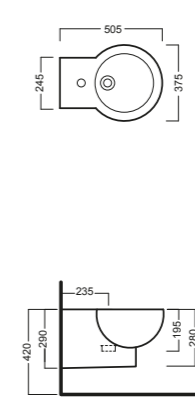



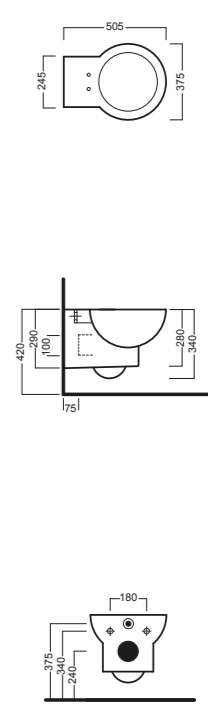













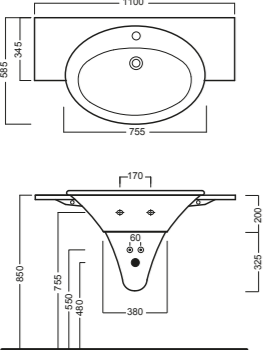
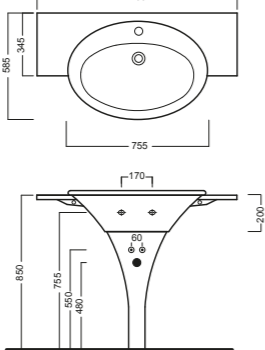
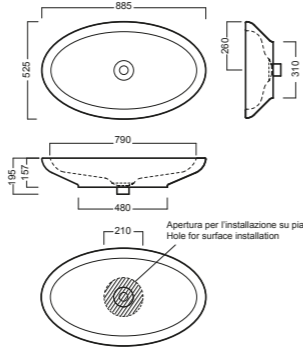
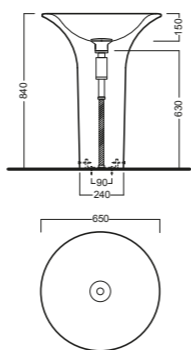
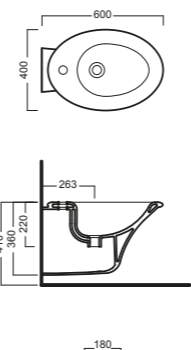
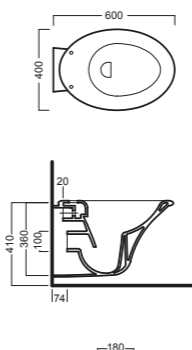
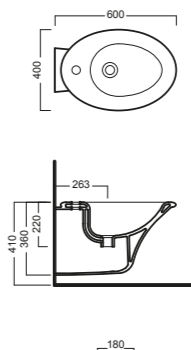
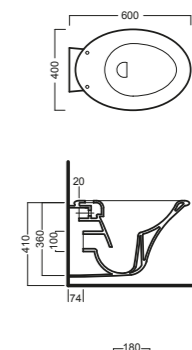







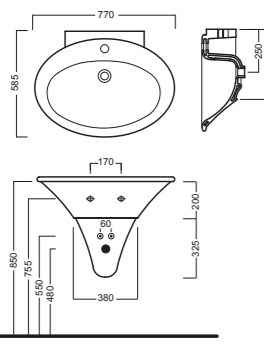
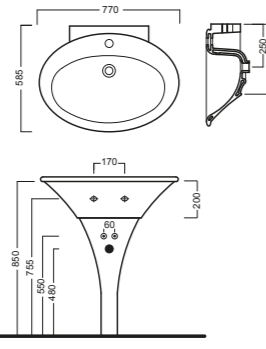
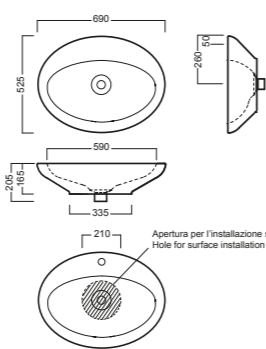
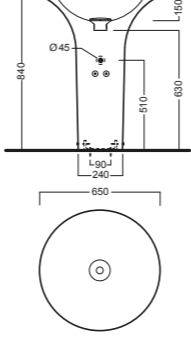
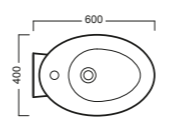
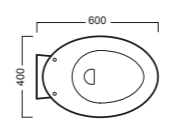
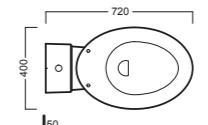

375x505

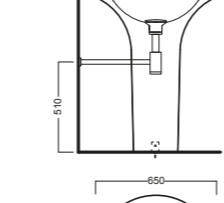
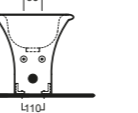

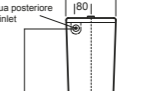
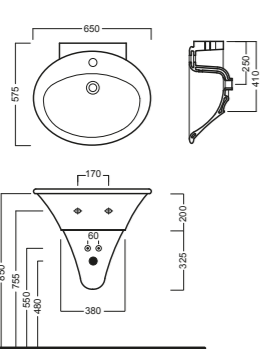
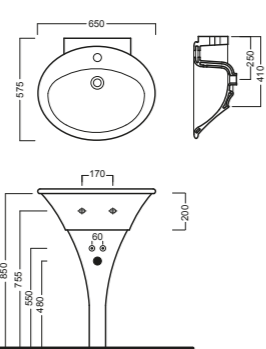
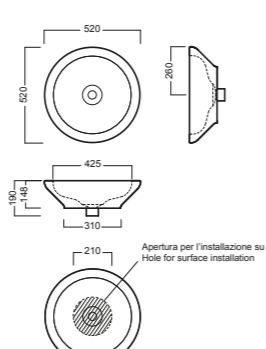
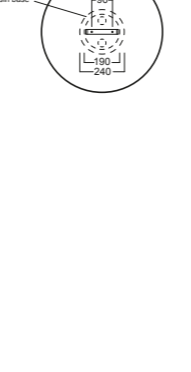
SCULTURE / SCULTURE EVENTO

DESIGN DAL LAGO ASSOCIATI

 <p>SCULTURE 1100x585</p>	 <p>SCULTURE 1100x585</p>	 <p>SCULTURE 885x525</p>	 <p>SCULTURE EVENTO 650x840 scarico terra floor outlet</p>	 <p>SCULTURE 400x600</p>	 <p>SCULTURE 400x600</p>	 <p>SCULTURE EVENTO 400x600</p>	 <p>SCULTURE EVENTO 400x600</p>
		 <p>Apertura per l'installazione su piano Hole for surface installation</p>					
 <p>SCULTURE 770x585</p>	 <p>SCULTURE 770x585</p>	 <p>SCULTURE 690x525</p>	 <p>scarico parete wall outlet</p>	 <p>SCULTURE 400x600</p>	 <p>SCULTURE 400x600</p>	 <p>SCULTURE 400x720</p>	
		 <p>Apertura per l'installazione su piano Hole for surface installation</p>					
 <p>SCULTURE 650x575</p>	 <p>SCULTURE 650x575</p>	 <p>SCULTURE 520x520</p>	 <p>base lavabo washbasin base</p>	 <p>SCULTURE 400x600</p>	 <p>SCULTURE 400x600</p>	 <p>SCULTURE 400x720</p>	
		 <p>Apertura per l'installazione su piano Hole for surface installation</p>				 <p>Entrata acqua laterale alta (sx-dx) Side-high water inlet (left-right)</p> <p>Entrata acqua posteriore Back water inlet</p> <p>Entrata acqua laterale bassa (sx) Bottom water inlet (left)</p>	

DOLCEVITA



1000x500

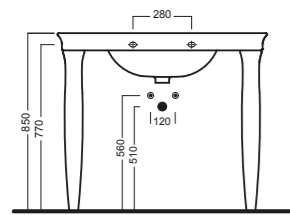
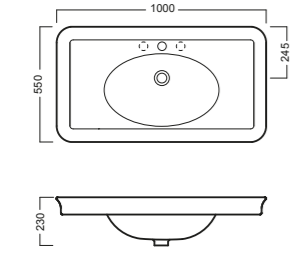

1000x500

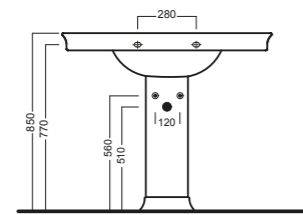
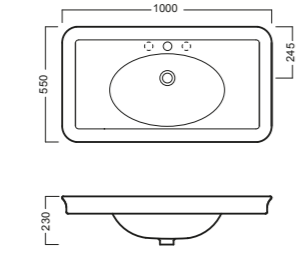

750x550

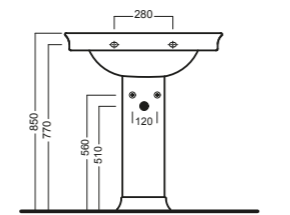
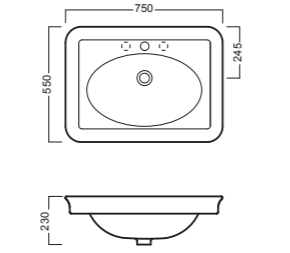

750x575

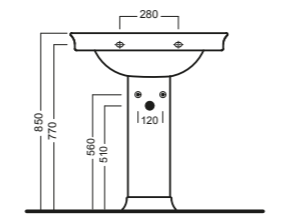
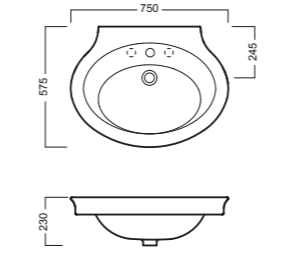

700x550

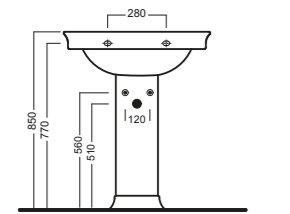
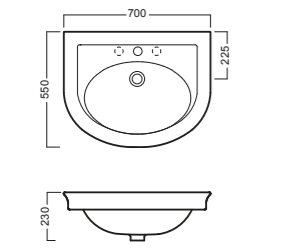

650x480

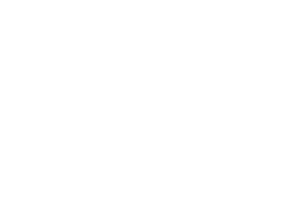
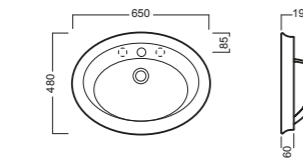

370x590

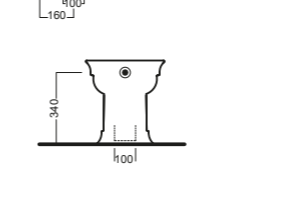
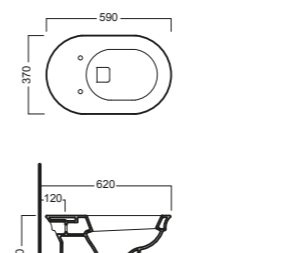

370x590

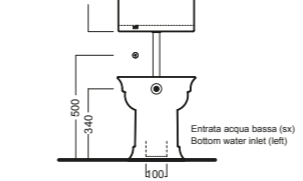
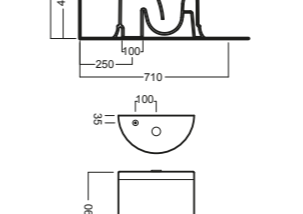
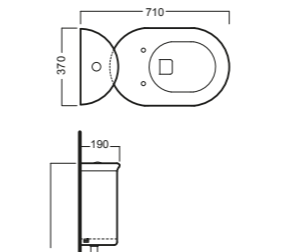

Entrata acqua bassa (sx)
Bottom water inlet (left)



370x590

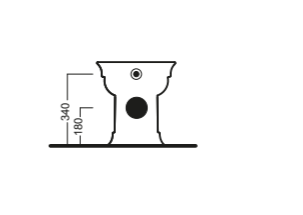
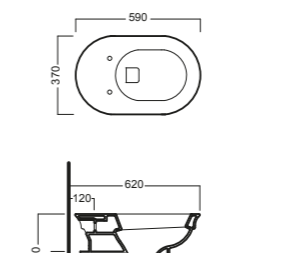

370x590

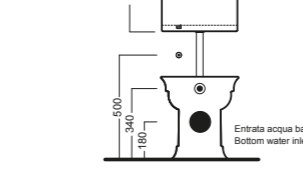
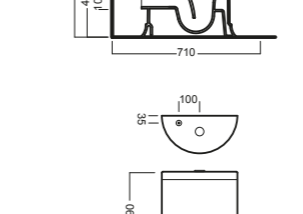
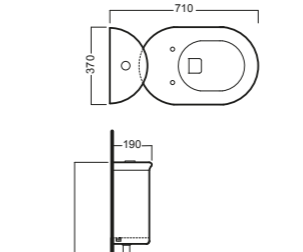

Entrata acqua bassa (sx)
Bottom water inlet (left)



370x595

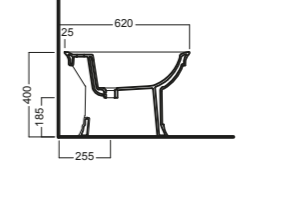
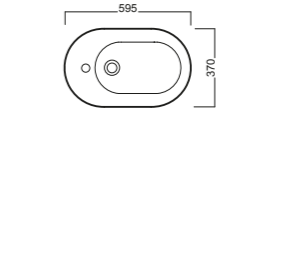

370x595

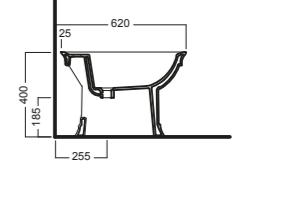
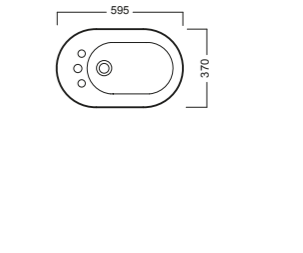

SHIRLEY



1205x495

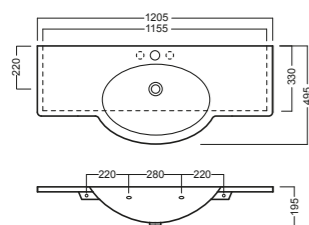

1055x495

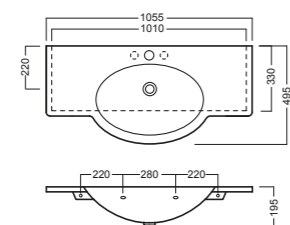

865x500

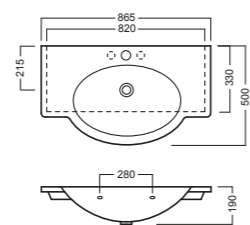

750x495

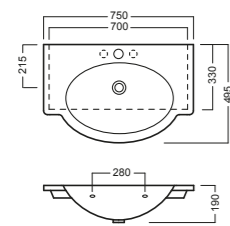

560x445

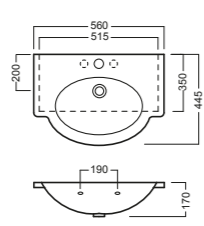

SOPHIE



1250x500

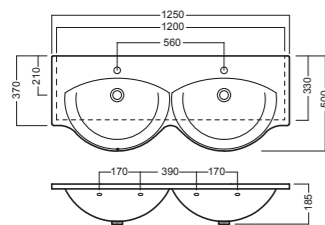

1200x500

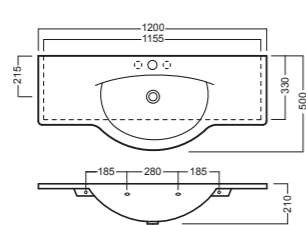

1050x495

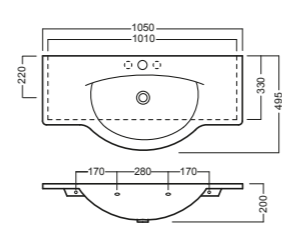

950x500

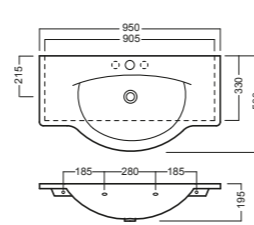

860x500

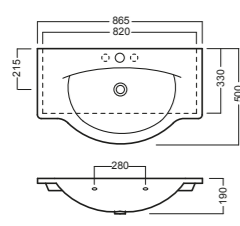

750x495

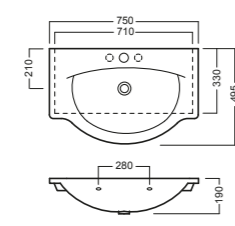

560x450

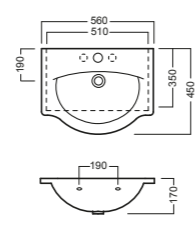

SUSAN



1255x500

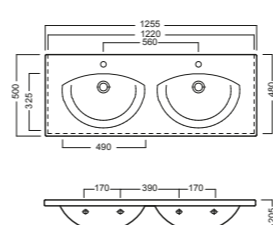

1105x500

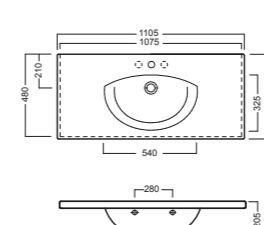

950x500 dx-rh

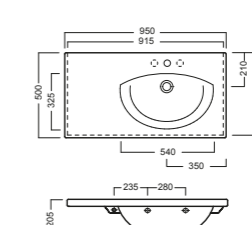

950x500 sx-lh

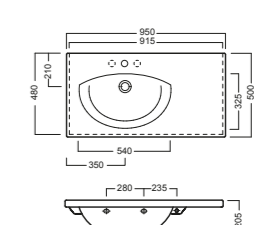

950x500

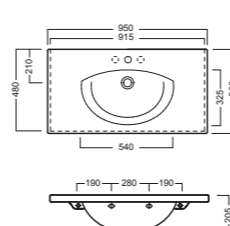

750x500

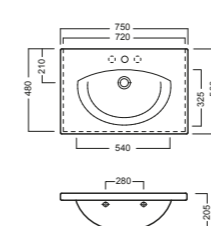

650x500

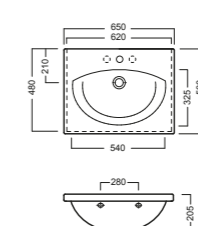

CANNES 2012



ERIKA 660x530

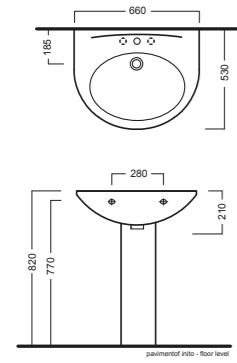

ERIKA 660x530

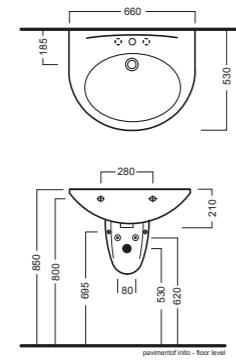

ERIKA 600x495

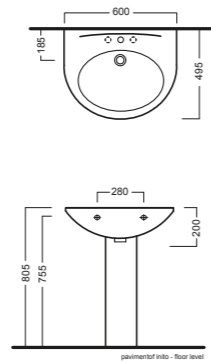

ERIKA 600x495

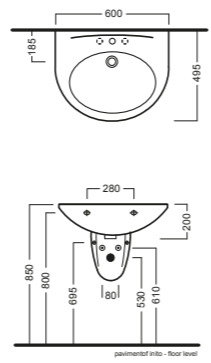

ERIKA 355x555

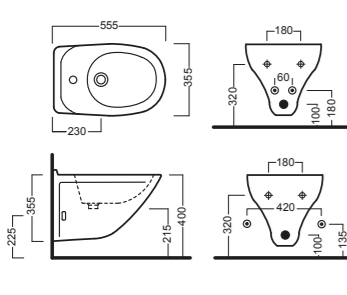

ERIKA 350x560

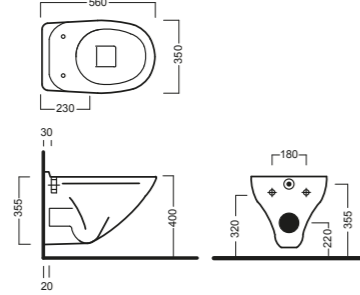

CANNES 365x520

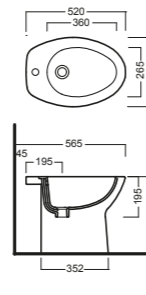

CANNES 360x520

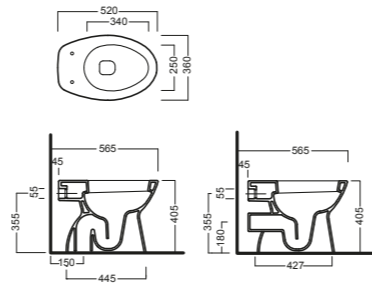

CANNES 368x670

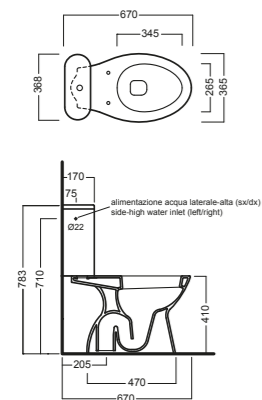

CANNES 368x665

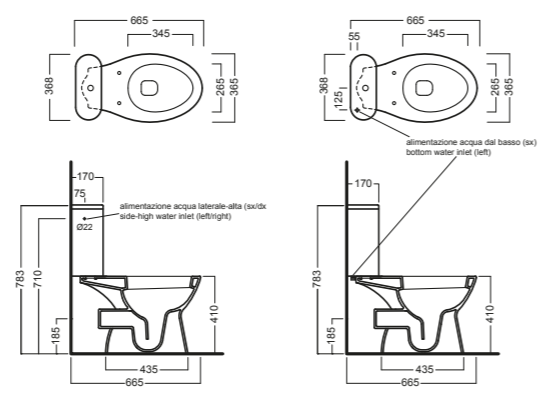

AUTONOMY



680x600

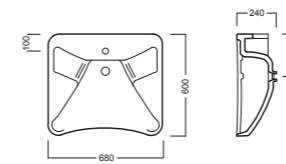

380x595

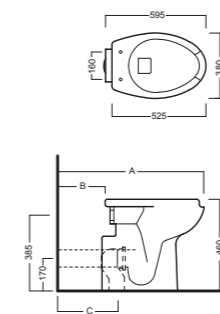

A	800	750	620
B	280	230	100
C	315	265	135

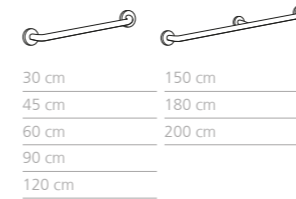

- 30 cm
- 45 cm
- 60 cm
- 90 cm
- 120 cm
- 150 cm
- 200 cm

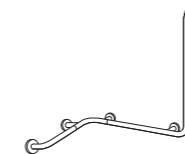

670x670x780
DX-RH / SX-LH



670x670
770x770

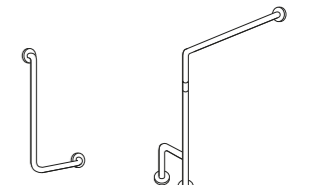

670x350
SX-LH / DX-RH

800x780x135

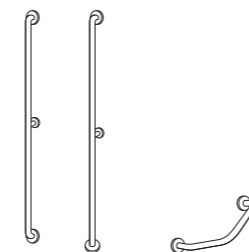

160 cm

180 cm

50 cm

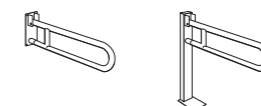

600x220x100

880x770x140



600x135x135
DX-RH

600x135x135
SX-LH

830x135x135
DX-RH

830x135x135
SX-LH

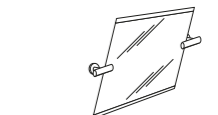

500x600



405x300

405x300



505x600

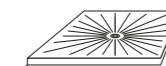

800x800

900x900

LAVABI INCASSO / SEMINCASSO



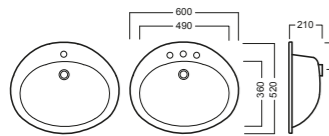

OVALINE 600x520





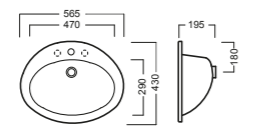

MARINE 565x430



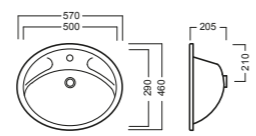

CAROLINE 570x460





BOULE 420x420

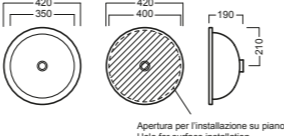

Apertura per l'installazione su piano
Hole for surface installation



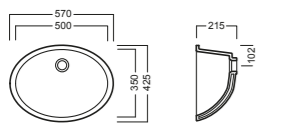

CATERINE 570x425





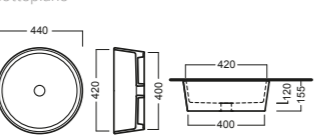

HAPPY HOUR 07:15 440x440
sottopiano





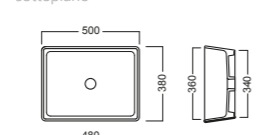

HAPPY HOUR 11:15 500x380
sottopiano



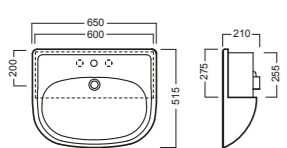

SEMINCASSO 650x515





HAPPY HOUR 09:30 480x480

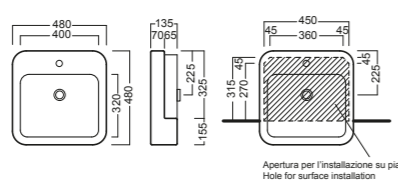



Apertura per l'installazione su piano
Hole for surface installation

LAVAMANI



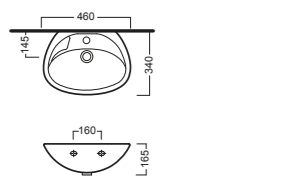

NINA 460x340





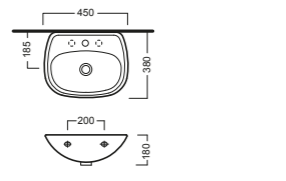

SELECTA 450x380





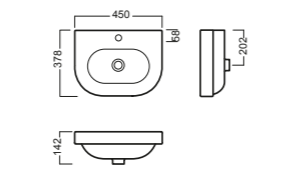

DAYTIME 450x378



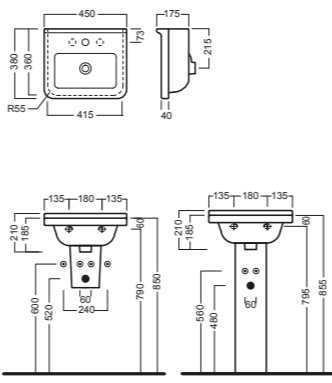

ERIKA pro 450x380





DINO 505x220

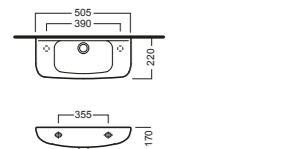

SPECIALI / TURCHE / ORINATOI



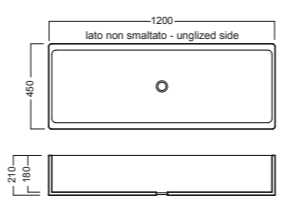

1200x450





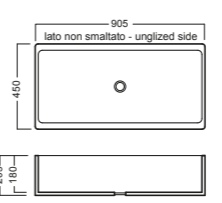

905x450





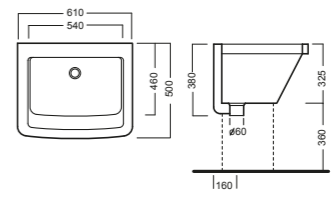

610x500





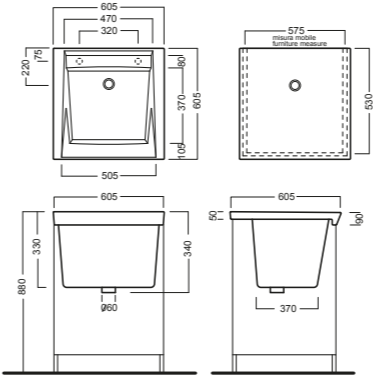

SIXTY LP 600x600





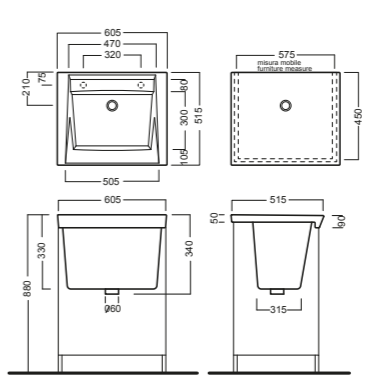

FIFTY LP 600x500





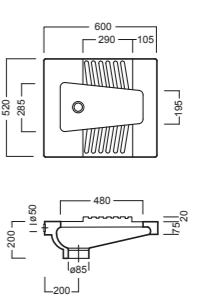

600x520





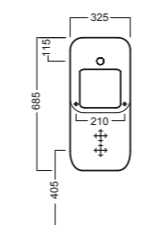
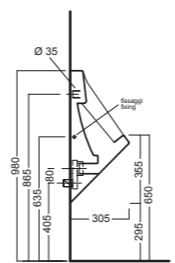

ORINATOIO FUSION 325x685



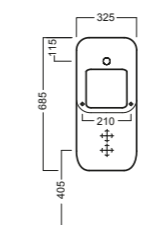
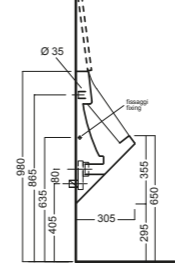

ORINATOIO FUSION 325x685



ORINATOIO FUSION 325x685

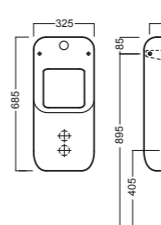
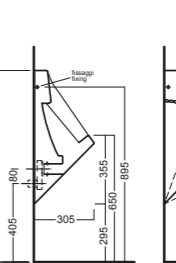

ORINATOIO 500x330

NOTE

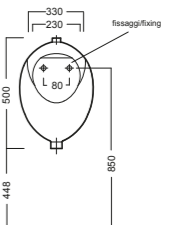
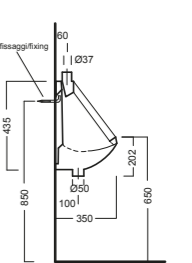

© Copyright Hatria SpA

Ceramiche Marazzi, Marazzi Tecnica e Ragno

Stampa Settembre 2012 (LIT)
5.000
CQY

Hatria si riserva il diritto di apportare, in qualsiasi momento e senza preavviso, modifiche tecniche e dimensionali ai propri prodotti.
Hatria reserves the right to change the models at any moment and without notice.

HATRIA 
MARAZZI GROUP

Viale Virgilio 30
41123 Modena Italia
tel. +39 059 384 350
fax +39 059 384 212

venditeitalia@hatria.com
exportdpt@hatria.com
marketing@hatria.com

www.hatria.com